

Log-Linear Models with Structured Outputs

Natural Language Processing
CS 4120/6120—Spring 2017
Northeastern University

David Smith
(some slides from Andrew McCallum)

Overview

- Sequence labeling task (cf. POS tagging)
- Independent classifiers
- HMMs
- (Conditional) Maximum Entropy Markov Models
- Conditional Random Fields
- Beyond Sequence Labeling

Sequence Labeling

- Inputs: $x = (x_1, \dots, x_n)$
- Labels: $y = (y_1, \dots, y_n)$
- Typical goal: Given x , predict y

- Example sequence labeling tasks
 - Part-of-speech tagging
 - Named-entity-recognition (NER)
 - Label people, places, organizations

NER Example:

Red Sox and Their Fans Let Loose



Elise Amendola/Associated Press

Fans of the slugger David Ortiz in Boston's Copley Square.

By [PETE THAMEL](#)

Published: October 31, 2007

[BOSTON](#), Oct. 30 — [Jonathan Papelbon](#) turned Boston's World Series victory parade into a full-scale dance party Tuesday as the [Red Sox](#) put an exclamation point on the 2007 season.

 E-MAIL

 PRINT

 REPRINTS

 SAVE

First Solution:

Maximum Entropy Classifier

- Conditional model $p(y|x)$.
 - Do not waste effort modeling $p(x)$, since x is given at test time anyway.
 - Allows more complicated input features, since we do not need to model dependencies between them.
- Feature functions $f(x,y)$:
 - $f_1(x,y) = \{ \text{word is Boston} \ \& \ y=\text{Location} \}$
 - $f_2(x,y) = \{ \text{first letter capitalized} \ \& \ y=\text{Name} \}$
 - $f_3(x,y) = \{ x \text{ is an HTML link} \ \& \ y=\text{Location} \}$

First Solution: MaxEnt Classifier

- How should we choose a classifier?
- Principle of maximum entropy
 - We want a classifier that:
 - Matches feature constraints from training data.
 - Predictions maximize entropy.
- There is a unique, exponential family distribution that meets these criteria.

First Solution: MaxEnt Classifier

- Problem with using a maximum entropy classifier for sequence labeling:
- It makes decisions at each position independently!

Second Solution: HMM

$$P(\mathbf{y}, \mathbf{x}) = \prod_t P(y_t | y_{t-1}) P(x | y_t)$$

- Defines a generative process.
- Can be viewed as a weighted finite state machine.

Second Solution: HMM

- How can represent we multiple features in an HMM?
 - Treat them as conditionally independent given the class label?
 - The example features we talked about are not independent.
 - Try to model a more complex generative process of the input features?
 - We may lose tractability (i.e. lose a dynamic programming for exact inference).

Second Solution: HMM

- Let's use a conditional model instead.

Third Solution: MEMM

- Use a series of maximum entropy classifiers that know the previous label.
- Define a Viterbi algorithm for inference.

$$P(\mathbf{y} \mid \mathbf{x}) = \prod_t P_{y_{t-1}}(y_t \mid \mathbf{x})$$

Third Solution: MEMM

- Use a series of maximum entropy classifiers that know the previous label.
- Define a Viterbi algorithm for inference.

$$P(\mathbf{y} \mid \mathbf{x}) = \prod_t P_{y_{t-1}}(y_t \mid \mathbf{x})$$

Cf. recurrent neural nets
but w/o exact Viterbi
decoding

Third Solution: MEMM

- Combines the advantages of maximum entropy and HMM!
- But there is a problem...

Problem with MEMMs: Label Bias

- In some state space configurations, MEMMs essentially completely ignore the inputs.

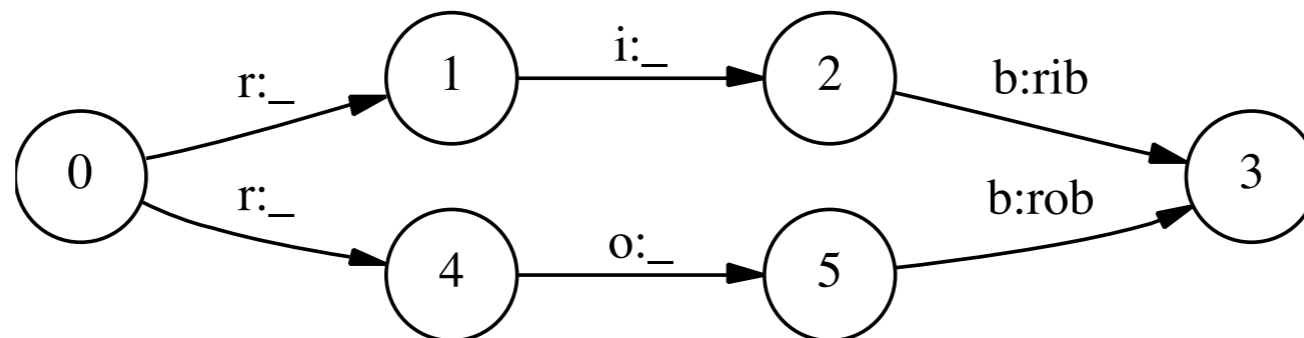

- This is not a problem for HMMs, because the input sequence is generated by the model.

Fourth Solution: Conditional Random Field

- Conditionally-trained, undirected graphical model.
- For a standard linear-chain structure:

$$P(\mathbf{y} \mid \mathbf{x}) = \prod_t \Psi_k(y_t, y_{t-1}, \mathbf{x})$$

$$\Psi_k(y_t, y_{t-1}, \mathbf{x}) = \exp\left(\sum_k \lambda_k f(y_t, y_{t-1}, \mathbf{x})\right)$$

Fourth Solution: CRF

- Have the advantages of MEMMs, but avoid the label bias problem.
- CRFs are globally normalized, whereas MEMMs are locally normalized.
- Widely used and applied. CRFs give state-the-art results in many domains.

Fourth Solution: CRF

- Have the advantages of MEMMs, but avoid the label bias problem.
- CRFs are globally normalized, whereas MEMMs are locally normalized.
- Widely used and applied to many NLP tasks. Achieved state-the-art results in many domains.

Remember, Z is the normalization constant. How do we compute it?

CRF Applications

- Part-of-speech tagging
- Named entity recognition
- Document layout (e.g. table) classification
- Gene prediction
- Chinese word segmentation
- Morphological disambiguation
- Citation parsing
- Etc., etc.

NER as Sequence Tagging

The Phoenicians came from the Red Sea

NER as Sequence Tagging

○ **B-E** ○ ○ ○ **B-L** **I-L**
The Phoenicians came from the Red Sea

NER as Sequence Tagging

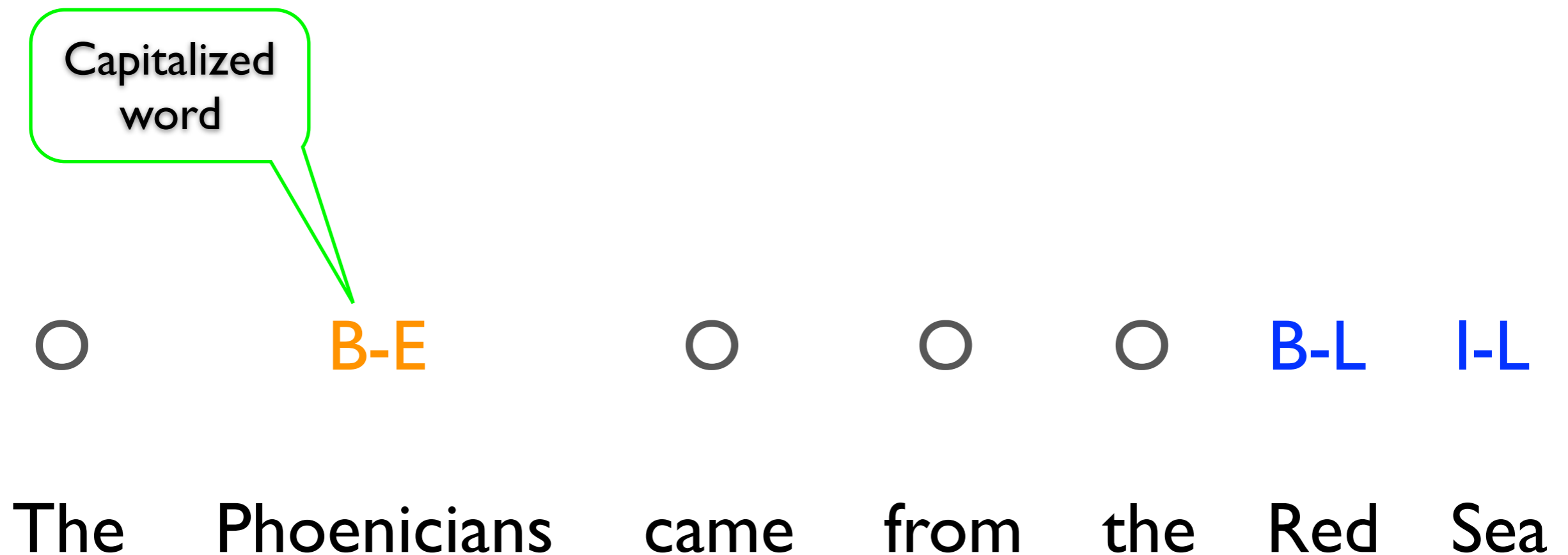

NER as Sequence Tagging

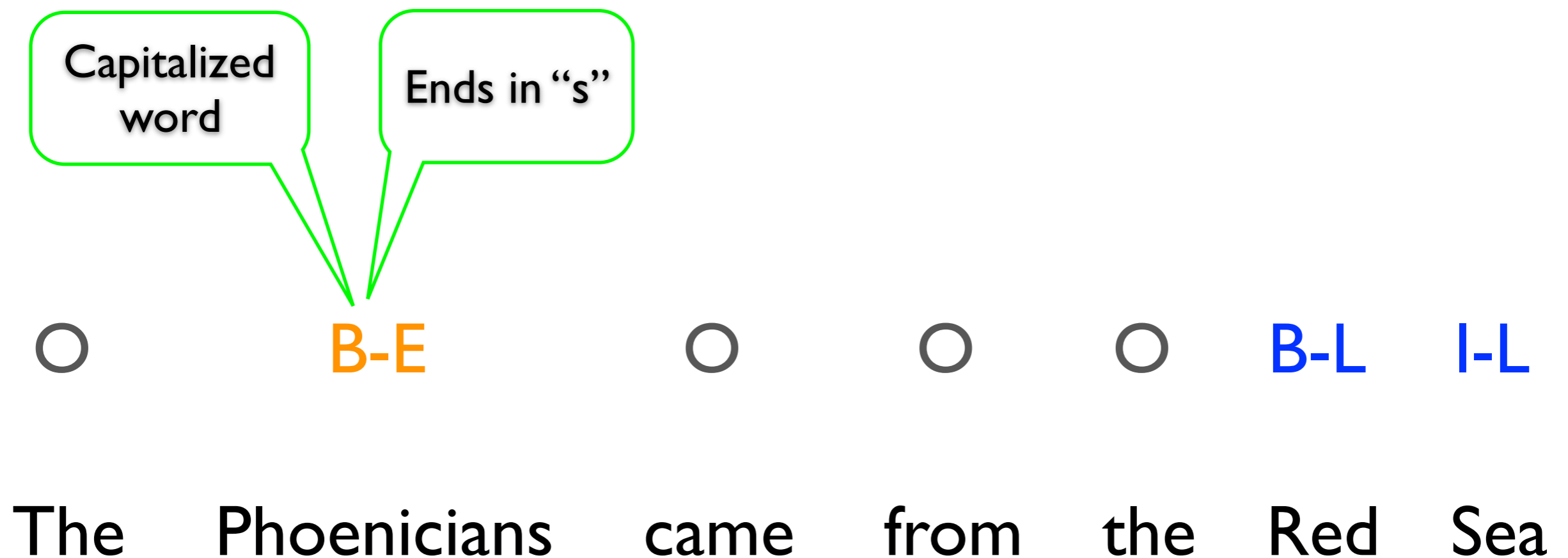

NER as Sequence Tagging

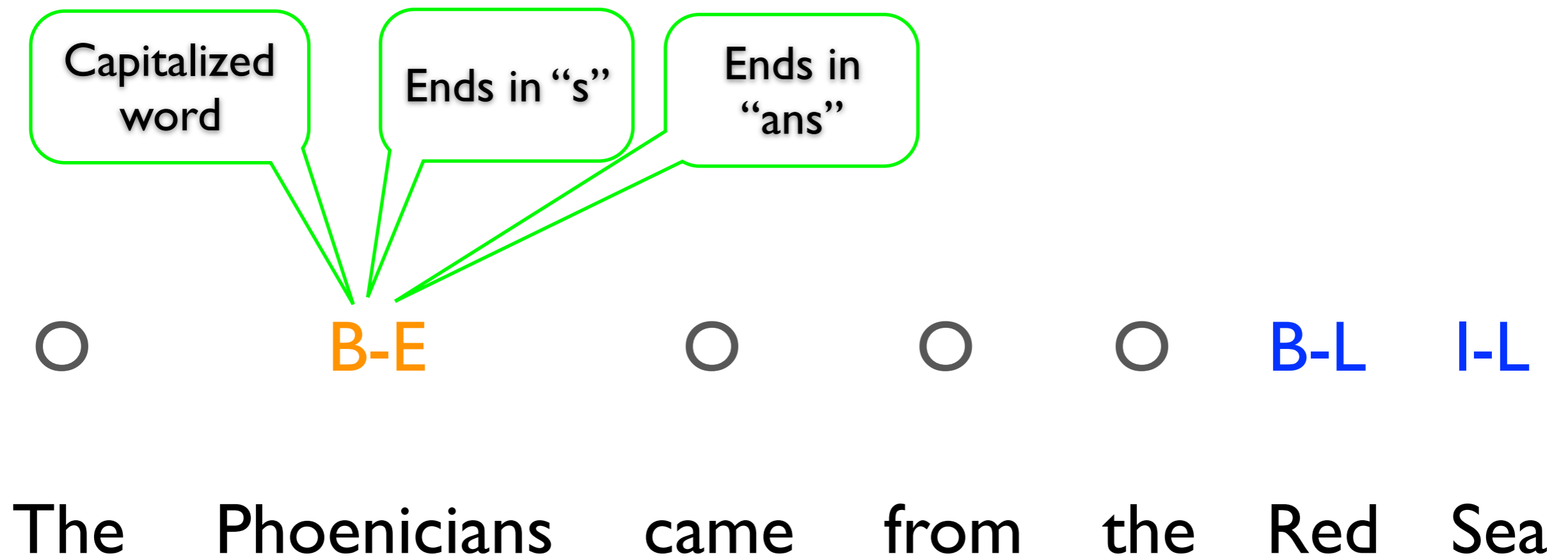

NER as Sequence Tagging

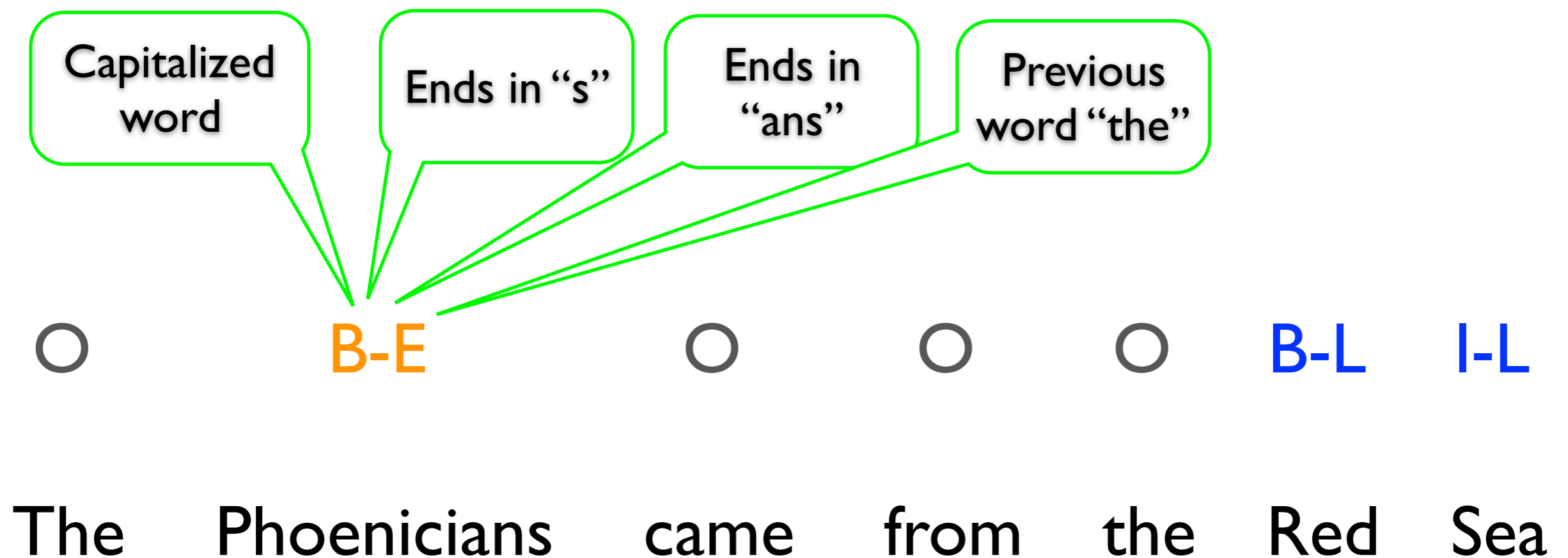

NER as Sequence Tagging

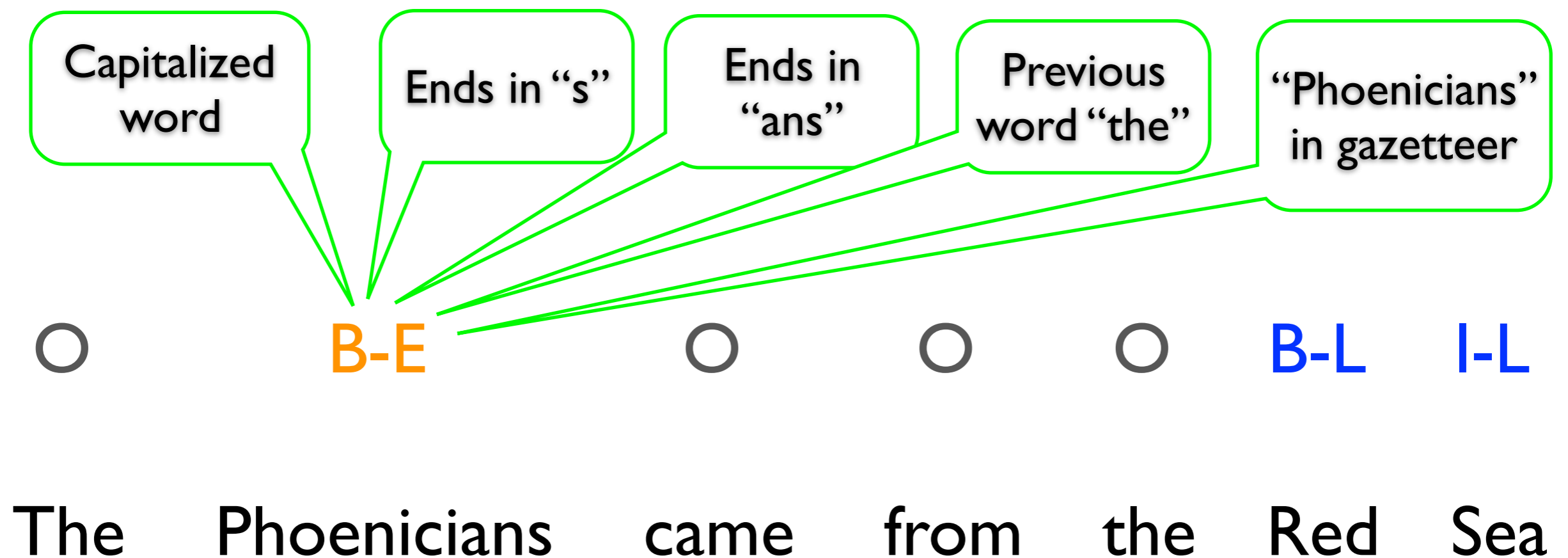

NER as Sequence Tagging

○ **B-E** ○ ○ ○ **B-L** **I-L**
The Phoenicians came from the Red Sea

NER as Sequence Tagging

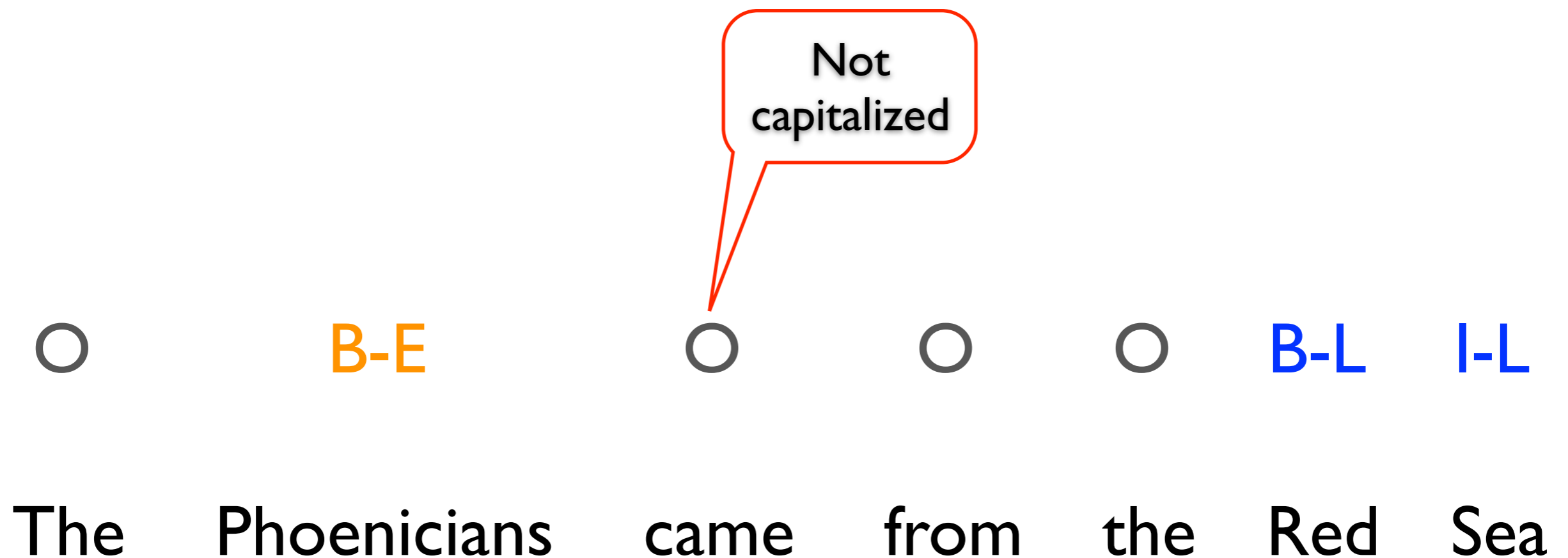

NER as Sequence Tagging

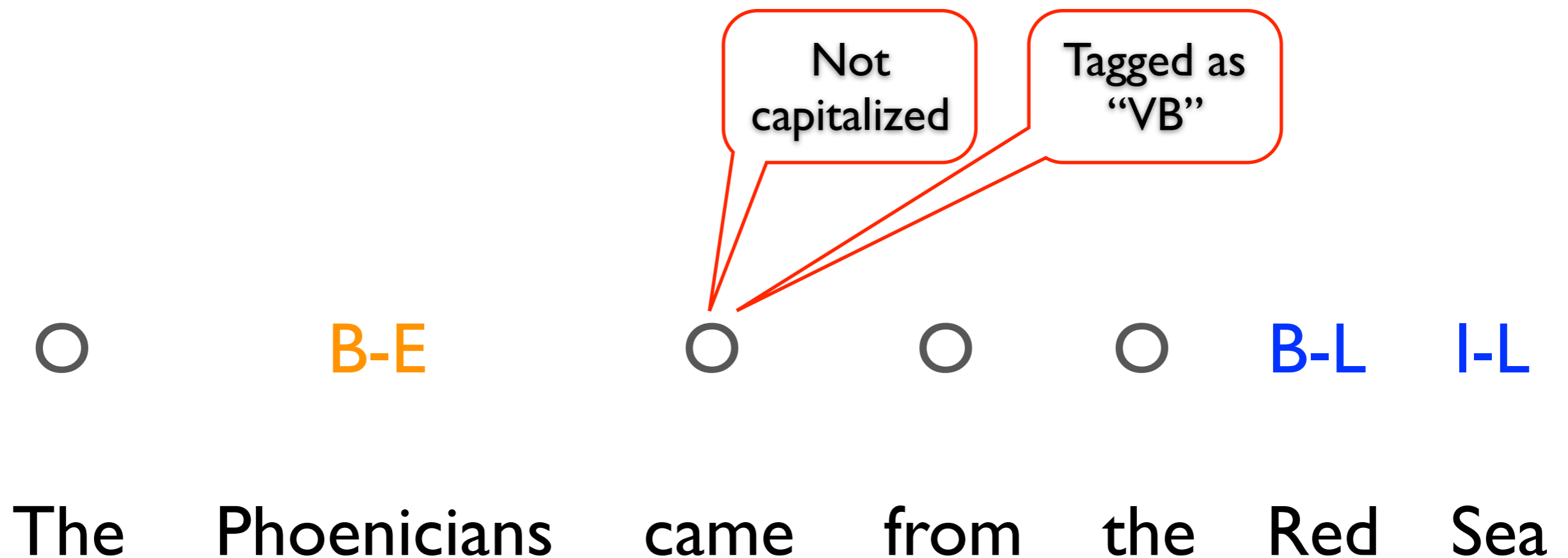

NER as Sequence Tagging

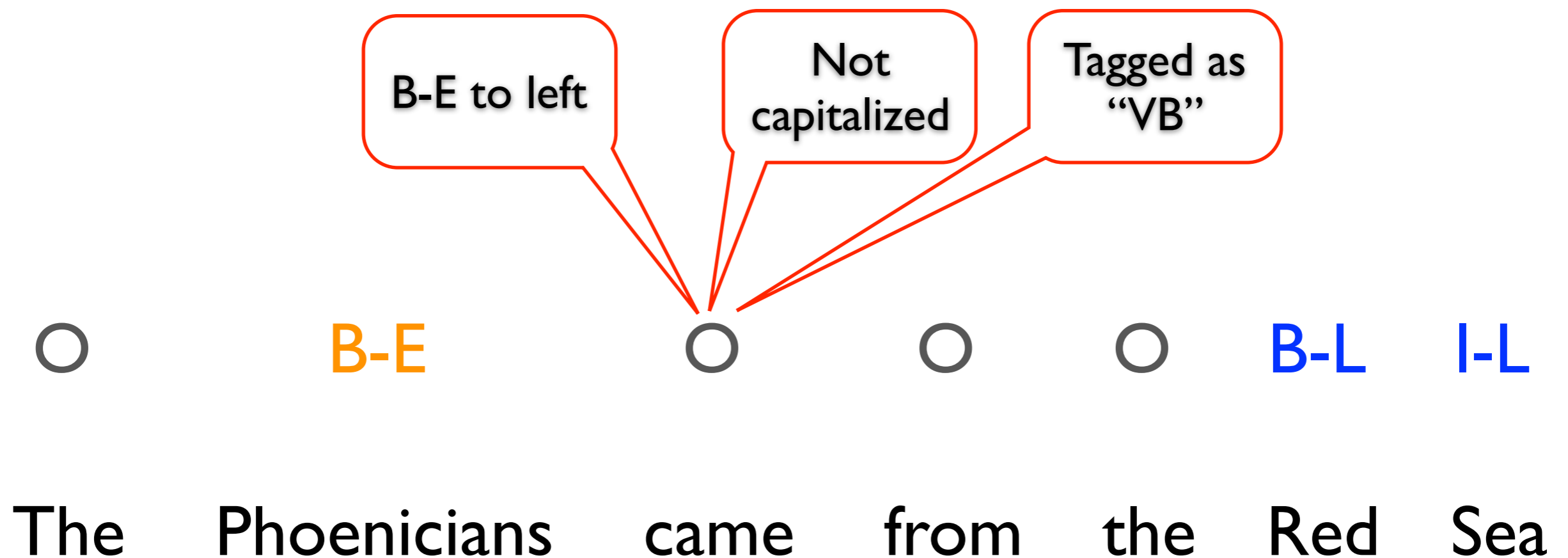

NER as Sequence Tagging

○ **B-E** ○ ○ ○ **B-L** **I-L**
The Phoenicians came from the Red Sea

NER as Sequence Tagging

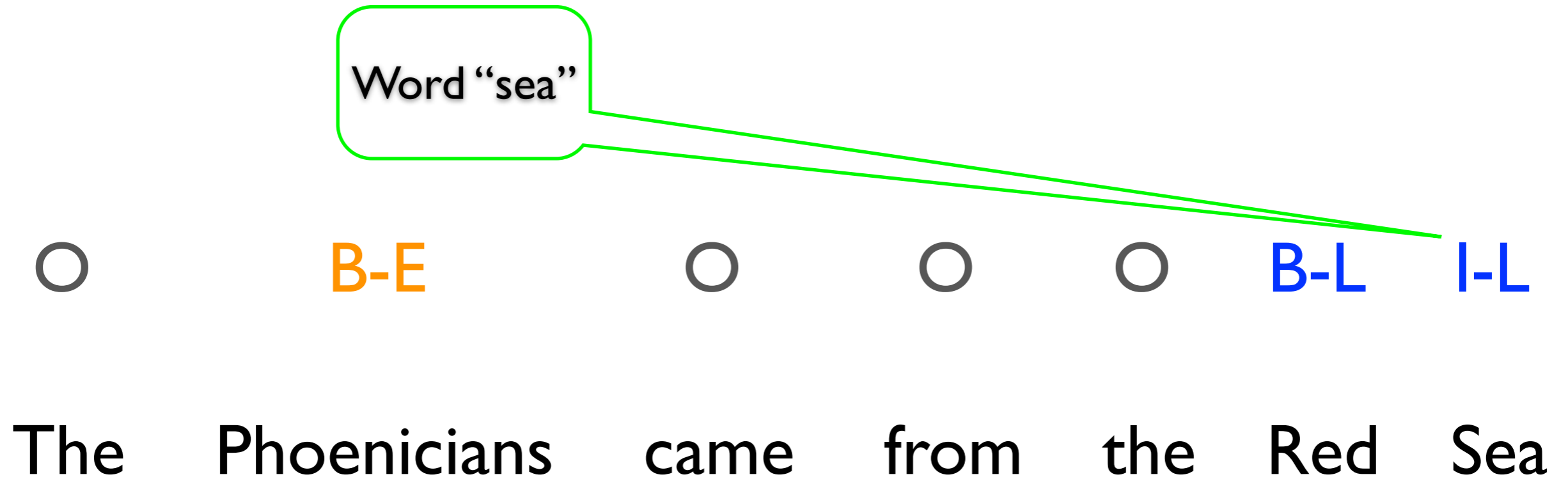

NER as Sequence Tagging

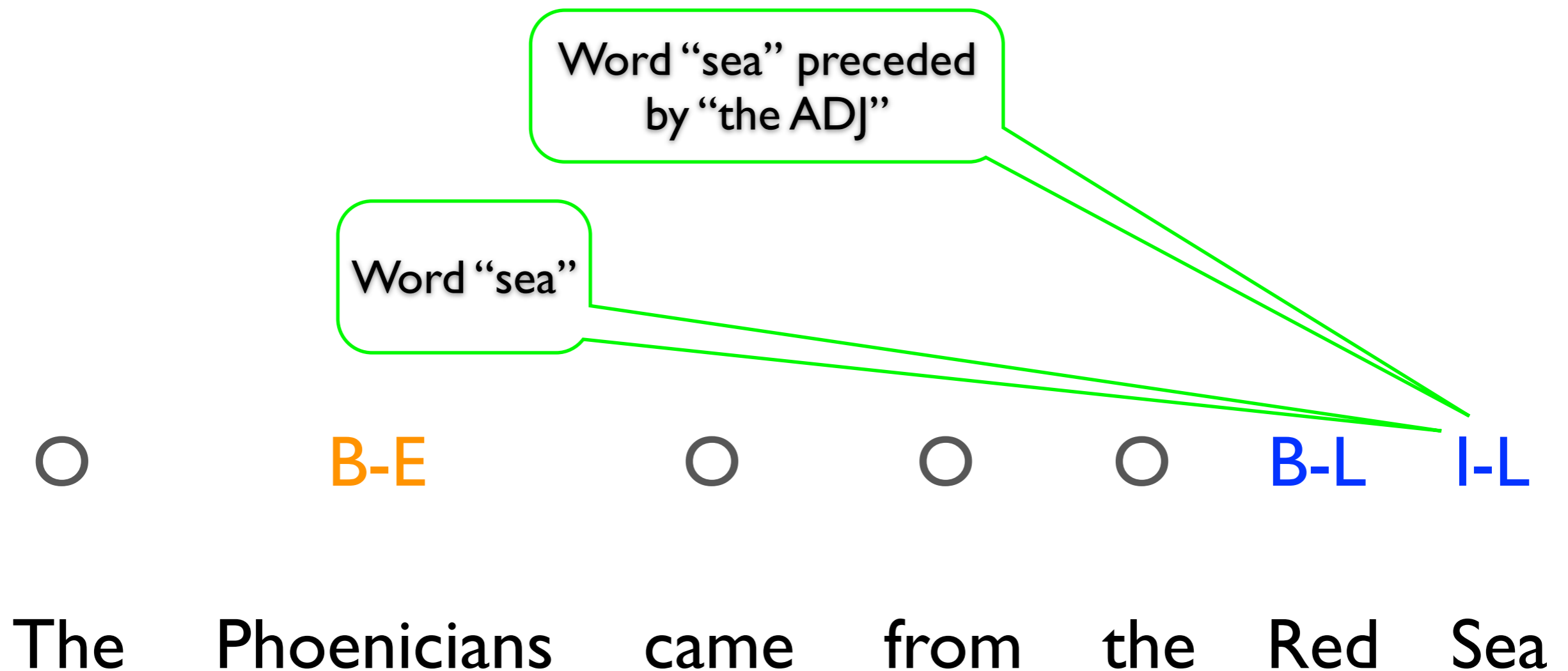

NER as Sequence Tagging

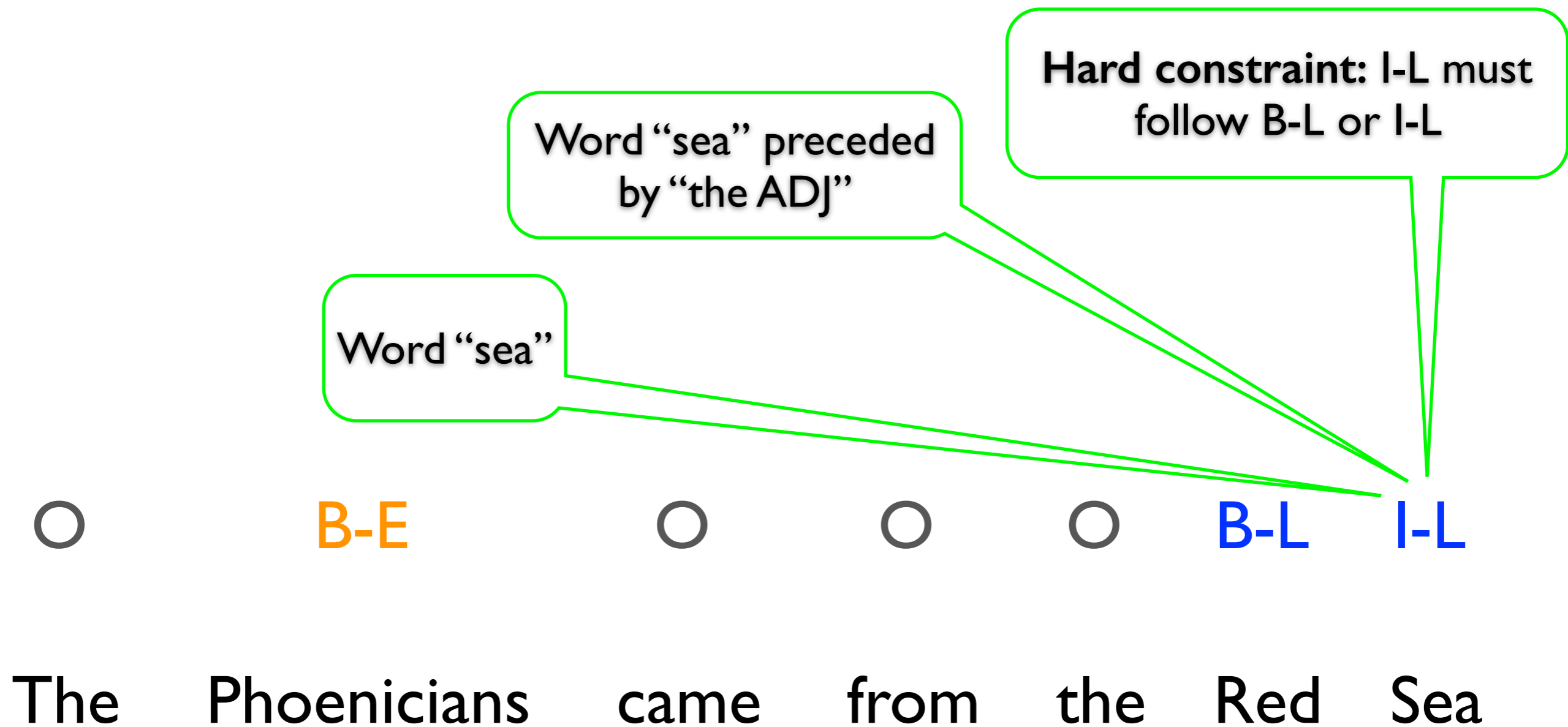

Overview

- What computations do we need?
- Smoothing log-linear models
- MEMMs vs. CRFs again
 - Action-based parsing and dependency parsing

Recipe for Conditional Training of $p(y | x)$

1. Gather constraints/features from training data

$$\alpha_{iy} = \tilde{E}[f_{iy}] = \sum_{x_j, y_j \in D} f_{iy}(x_j, y_j)$$

2. Initialize all parameters to zero

3. Classify training data with current parameters; calculate expectations

$$E_{\Theta}[f_{iy}] = \sum_{x_j \in D} \sum_{y'} p_{\Theta}(y' | x_j) f_{iy}(x_j, y')$$

4. Gradient is $\tilde{E}[f_{iy}] - E_{\Theta}[f_{iy}]$

5. Take a step in the direction of the gradient

6. Repeat from 3 until convergence

Recipe for Conditional Training of $p(y | x)$

1. Gather constraints/features from training data

$$\alpha_{iy} = \tilde{E}[f_{iy}] = \sum_{x_j, y_j \in D} f_{iy}(x_j, y_j)$$

2. Initialize all parameters to zero

3. Classify training data with current parameters; calculate expectations

$$E_{\Theta}[f_{iy}] = \sum_{x_j \in D} \sum_{y'} p_{\Theta}(y' | x_j) f_{iy}(x_j, y')$$

4. Gradient is $\tilde{E}[f_{iy}] - E_{\Theta}[f_{iy}]$

5. Take a step in the direction of the gradient

6. Repeat from 3 until convergence

Where have we seen expected counts before?

Recipe for Conditional Training of $p(y | x)$

1. Gather constraints/features from training data

$$\alpha_{iy} = \tilde{E}[f_{iy}] = \sum_{x_j, y_j \in D} f_{iy}(x_j, y_j)$$

2. Initialize all parameters to zero

3. Classify training data with current parameters; calculate expectations

$$E_{\Theta}[f_{iy}] = \sum_{x_j \in D} \sum_{y'} p_{\Theta}(y' | x_j) f_{iy}(x_j, y')$$

4. Gradient is $\tilde{E}[f_{iy}] - E_{\Theta}[f_{iy}]$

EM!

5. Take a step in the direction of the gradient

6. Repeat from 3 until convergence

Where have we seen expected counts before?

Gradient-Based Training

- $\lambda := \lambda + \text{rate} * \text{Gradient}(F)$
- After all training examples? (batch)
- After every example? (on-line)
- Use second derivative for faster learning?
- A big field: numerical optimization

Parsing as Structured Prediction

Shift-reduce parsing

Stack	Input remaining	Action
()	Book that flight	shift
(Book)	that flight	reduce, Verb \rightarrow book, (Choice #1 of 2)
(Verb)	that flight	shift
(Verb that)	flight	reduce, Det \rightarrow that
(Verb Det)	flight	shift
(Verb Det flight)		reduce, Noun \rightarrow flight
(Verb Det Noun)		reduce, NOM \rightarrow Noun
(Verb Det NOM)		reduce, NP \rightarrow Det NOM
(Verb NP)		reduce, VP \rightarrow Verb NP
(Verb)		reduce, S \rightarrow V
(S)		SUCCESS!

Ambiguity may lead to the need for backtracking.

Shift-reduce parsing

Stack	Input remaining	Action
()	Book that flight	shift
(Book)	that flight	reduce, Verb \rightarrow book, (Choice #1 of 2)
(Verb)	that flight	shift
(Verb that)	flight	reduce, Det \rightarrow that
(Verb Det)	flight	shift
(Verb Det flight)		reduce, Noun \rightarrow flight
(Verb Det Noun)		reduce, NOM \rightarrow Noun
(Verb Det NOM)		reduce, NP \rightarrow Det NOM
(Verb NP)		reduce, VP \rightarrow Verb NP
(Verb)		reduce, S \rightarrow V
(S)		SUCCESS!

~~Ambiguity may lead to the need for backtracking.~~

Shift-reduce parsing

Stack	Input remaining	Action
()	Book that flight	shift
(Book)	that flight	reduce, Verb \rightarrow book, (Choice #1 of 2)
(Verb)	that flight	shift
(Verb that)	flight	reduce, Det \rightarrow that
(Verb Det)	flight	shift
(Verb Det flight)		reduce, Noun \rightarrow flight
(Verb Det Noun)		reduce, NOM \rightarrow Noun
(Verb Det NOM)		reduce, NP \rightarrow Det NOM
(Verb NP)		reduce, VP \rightarrow Verb NP
(Verb)		reduce, S \rightarrow V
(S)		SUCCESS!

~~Ambiguity may lead to the need for backtracking.~~

Train log-linear model of
 $p(\text{action} \mid \text{context})$

Compare to an MEMM

Shift-reduce parsing

Stack	Input remaining	Action
()	Book that flight	shift
(Book)	that flight	reduce, Verb \rightarrow book, (Choice #1 of 2)
(Verb)	that flight	shift
(Verb that)	flight	reduce, Det \rightarrow that
(Verb Det)	flight	shift
(Verb Det flight)		reduce, Noun \rightarrow flight
(Verb Det Noun)		reduce, NOM \rightarrow Noun
(Verb Det NOM)		reduce, NP \rightarrow Det NOM
(Verb NP)		reduce, VP \rightarrow Verb NP
(Verb)		reduce, S \rightarrow V
(S)		SUCCESS!

~~Ambiguity may lead to the need for backtracking.~~

Train log-linear model of
 $p(\text{action} \mid \text{context})$

Structured Log-Linear Models

Structured Log-Linear Models

- Linear model for scoring structures

$$\text{score}(out, in) = \theta \cdot \text{features}(out, in)$$

Structured Log-Linear Models

- Linear model for scoring structures
- Get a probability distribution by normalizing

$$\text{score}(out, in) = \theta \cdot \text{features}(out, in)$$

$$p(out \mid in) = \frac{1}{Z} e^{\text{score}(out, in)} \quad Z = \sum_{out' \in GEN(in)} e^{\text{score}(out', in)}$$

Structured Log-Linear Models

- Linear model for scoring structures
- Get a probability distribution by normalizing
 - ❖ Viz. logistic regression, Markov random fields, undirected graphical models

$$\text{score}(out, in) = \theta \cdot \text{features}(out, in)$$

$$p(out \mid in) = \frac{1}{Z} e^{\text{score}(out, in)} \quad Z = \sum_{out' \in GEN(in)} e^{\text{score}(out', in)}$$

Structured Log-Linear Models

- Linear model for scoring structures
- Get a probability distribution by normalizing
 - ❖ Viz. logistic regression, Markov random fields, undirected graphical models

Usually the bottleneck in NLP

$$\text{score}(out, in) = \theta \cdot \text{features}(out, in)$$

$$p(out | in) = \frac{1}{Z} e^{\text{score}(out, in)} \quad Z = \sum_{out' \in GEN(in)} e^{\text{score}(out', in)}$$

Structured Log-Linear Models

- Linear model for scoring structures
- Get a probability distribution by normalizing
 - ❖ Viz. logistic regression, Markov random fields, undirected graphical models
- Inference: sampling, variational methods, dynamic programming, local search, ...

Usually the bottleneck in NLP

$$\text{score}(out, in) = \theta \cdot \text{features}(out, in)$$

$$p(out | in) = \frac{1}{Z} e^{\text{score}(out, in)} \quad Z = \sum_{out' \in GEN(in)} e^{\text{score}(out', in)}$$

Structured Log-Linear Models

- Linear model for scoring structures
- Get a probability distribution by normalizing
 - ❖ Viz. logistic regression, Markov random fields, undirected graphical models
- Inference: sampling, variational methods, dynamic programming, local search, ...
- Training: maximum likelihood, minimum risk, etc.

Usually the bottleneck in NLP

$$\text{score}(out, in) = \theta \cdot \text{features}(out, in)$$

$$p(out | in) = \frac{1}{Z} e^{\text{score}(out, in)} \quad Z = \sum_{out' \in GEN(in)} e^{\text{score}(out', in)}$$

Structured Log-Linear Models

With latent variables

- Several layers of linguistic structure
- Unknown correspondences
- Naturally handled by probabilistic framework
- Several inference setups, for example:

$$p(out_1 | in) = \sum_{out_2, alignment} p(out_1, out_2, alignment | in)$$

Structured Log-Linear Models

With latent variables

- Several layers of linguistic structure
- Unknown correspondences
- Naturally handled by probabilistic framework
- Several inference setups, for example:

$$p(out_1 | in) = \sum_{out_2, alignment} p(out_1, out_2, alignment | in)$$



Another computational problem

Edge-Factored Parsers

- No global features of a parse (*McDonald et al. 2005*)
- Each feature is attached to some edge
- *MST or CKY-like DP for fast $O(n^2)$ or $O(n^3)$ parsing*

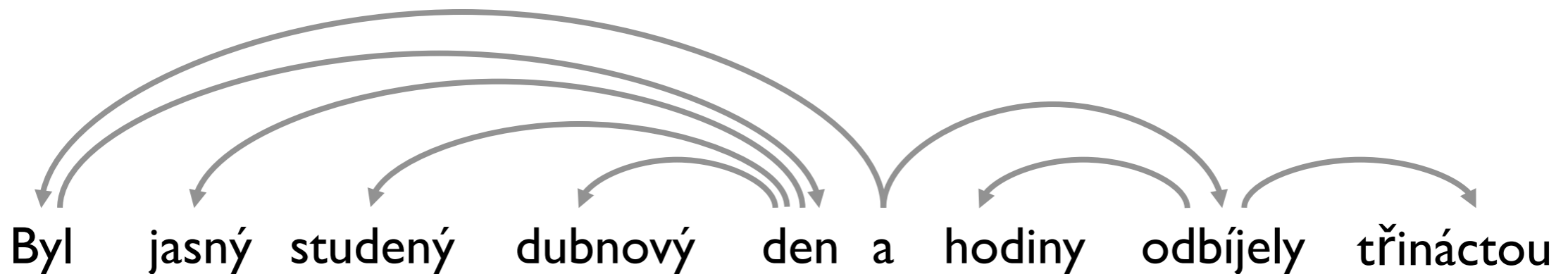

“It was a bright cold day in April and the clocks were striking thirteen”

Edge-Factored Parsers

- Is this a good edge?

Byl jasný studený dubnový den a hodiny odbíjely třináctou

A curved arrow starts above the word 'den' and points to the word 'jasný', indicating a dependency or edge between them.

“It was a bright cold day in April and the clocks were striking thirteen”

Edge-Factored Parsers

- Is this a good edge?

yes, lots of positive features ...

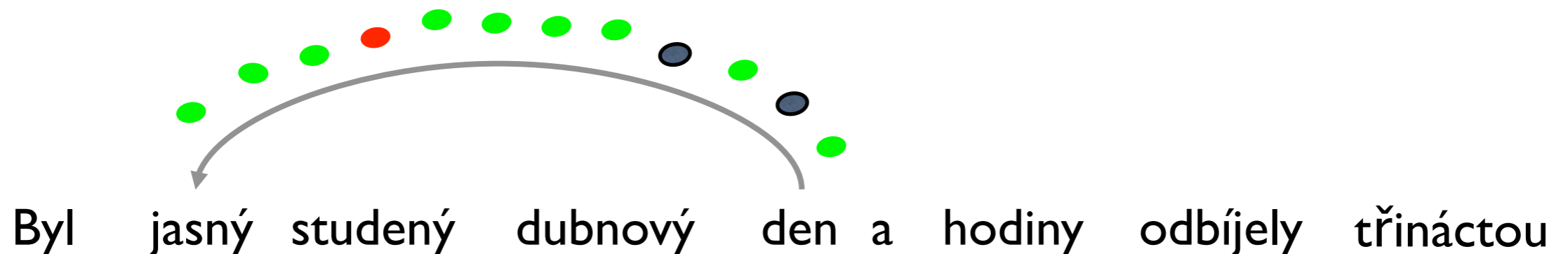

“It was a bright cold day in April and the clocks were striking thirteen”

Edge-Factored Parsers

- Is this a good edge?

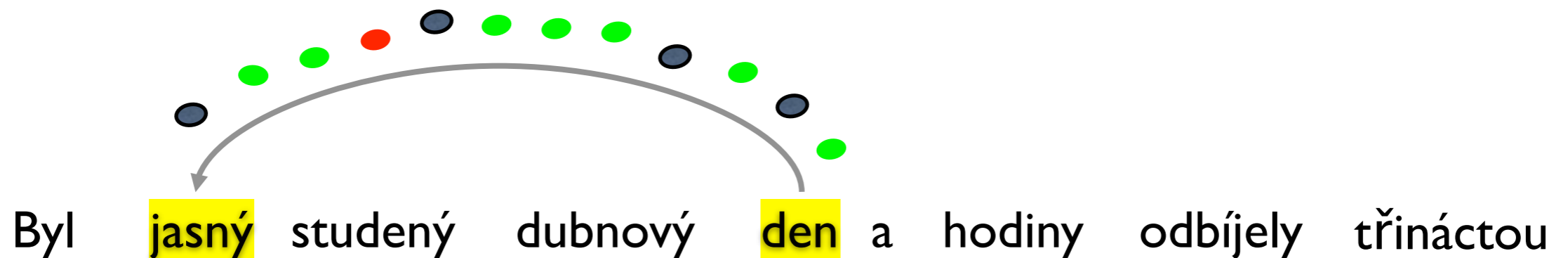

“It was a bright cold day in April and the clocks were striking thirteen”

Edge-Factored Parsers

- Is this a good edge?

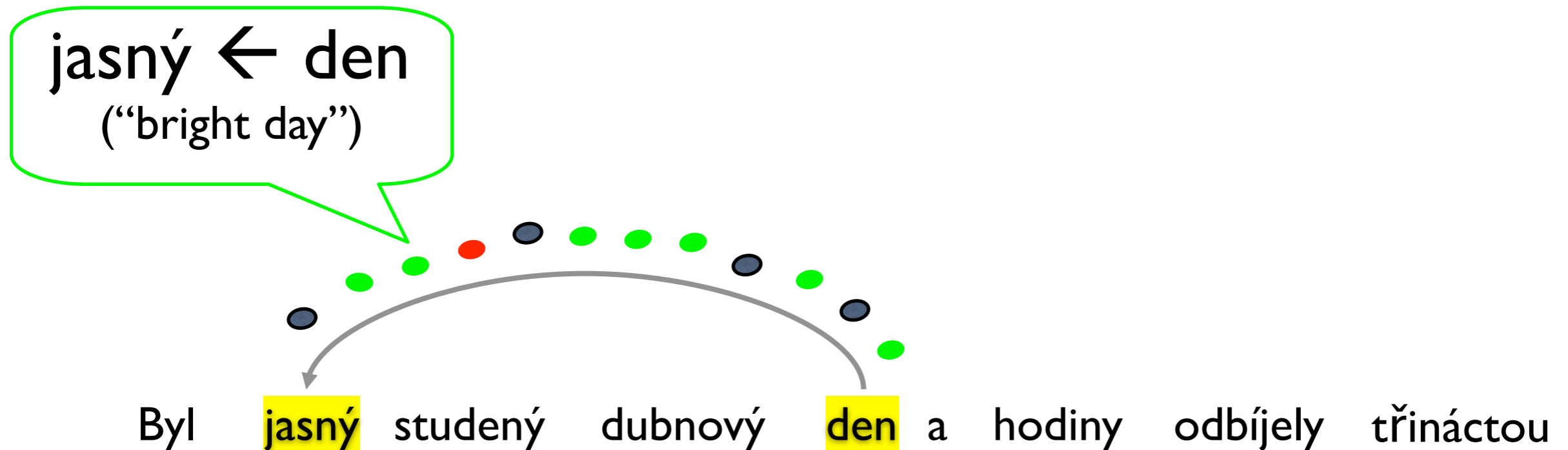

“It was a bright cold day in April and the clocks were striking thirteen”

Edge-Factored Parsers

- Is this a good edge?

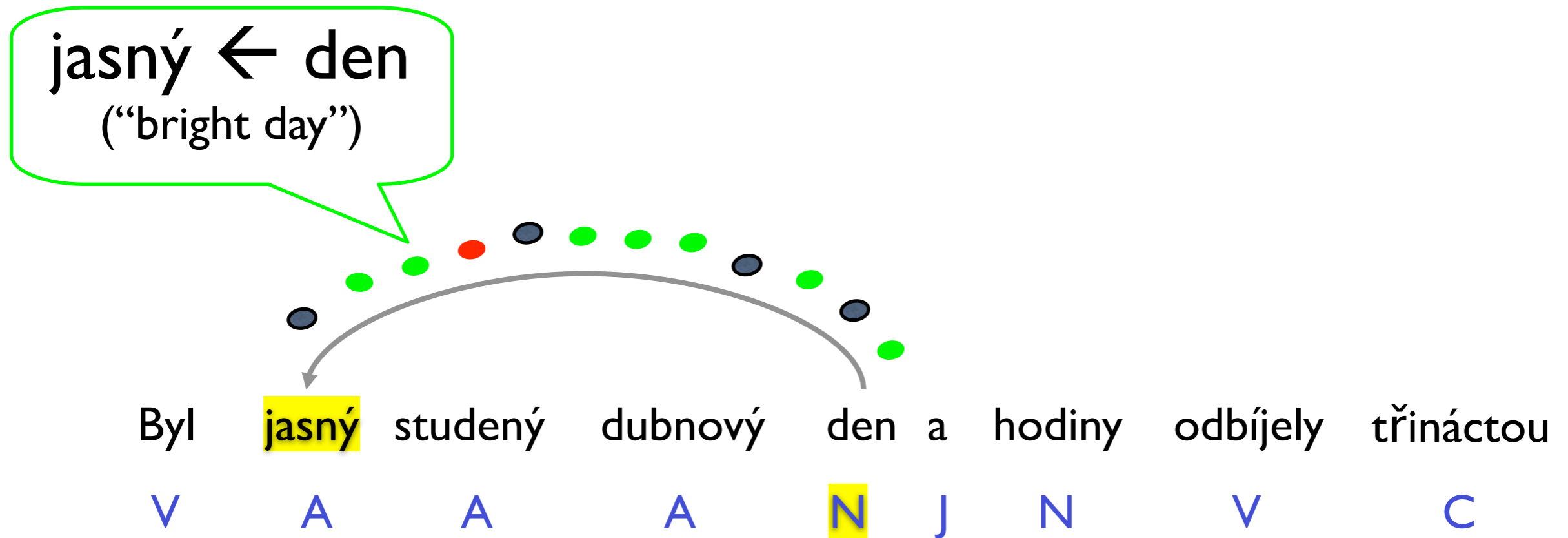

“It was a bright cold day in April and the clocks were striking thirteen”

Edge-Factored Parsers

- Is this a good edge?

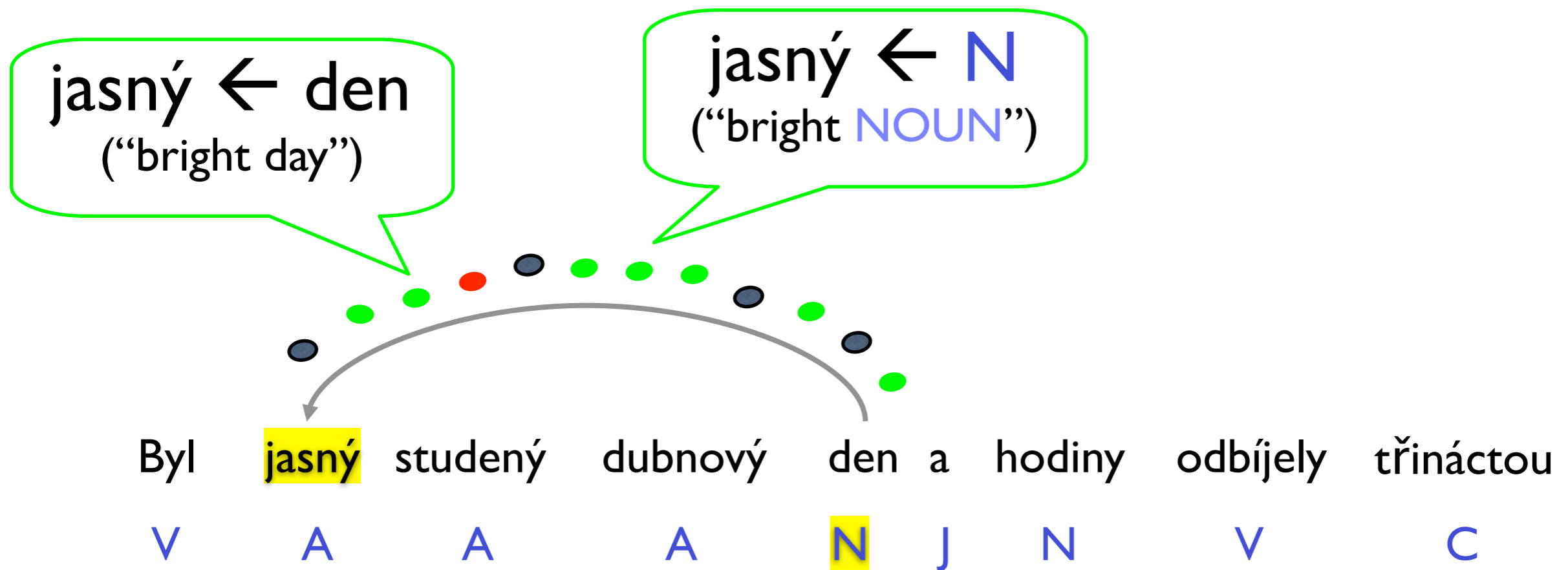

“It was a bright cold day in April and the clocks were striking thirteen”

Edge-Factored Parsers

- Is this a good edge?

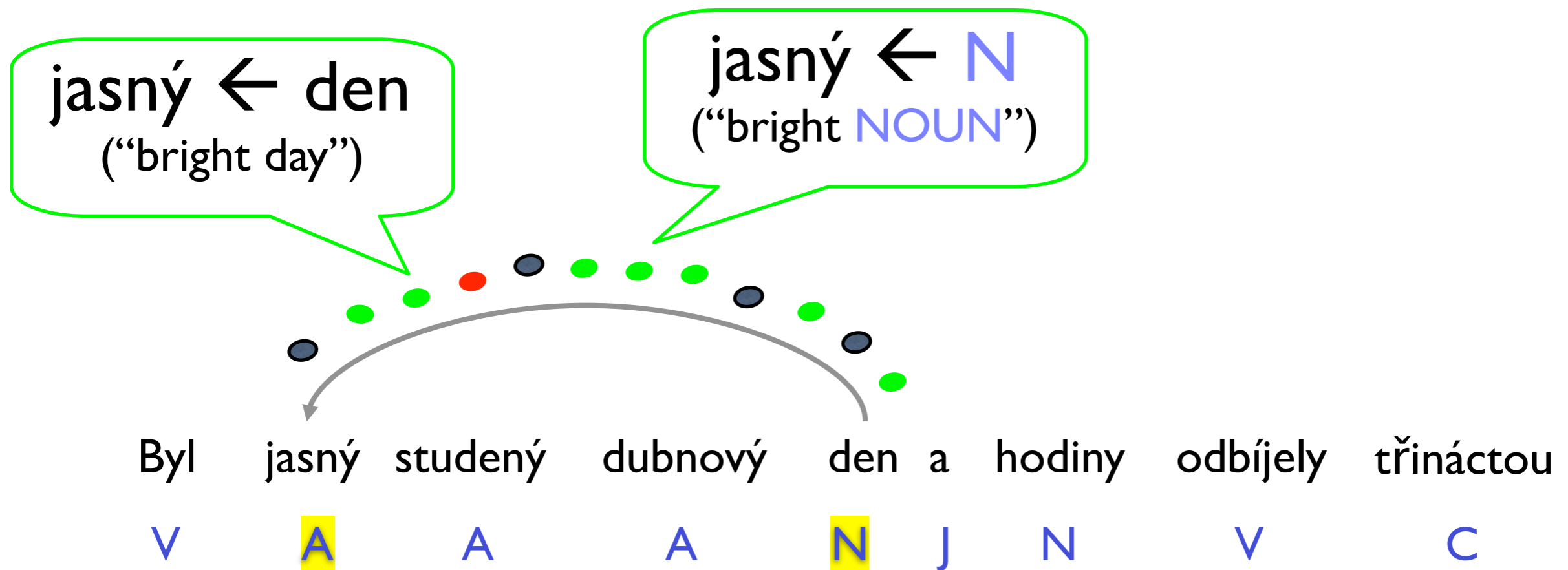

“It was a bright cold day in April and the clocks were striking thirteen”

Edge-Factored Parsers

- Is this a good edge?

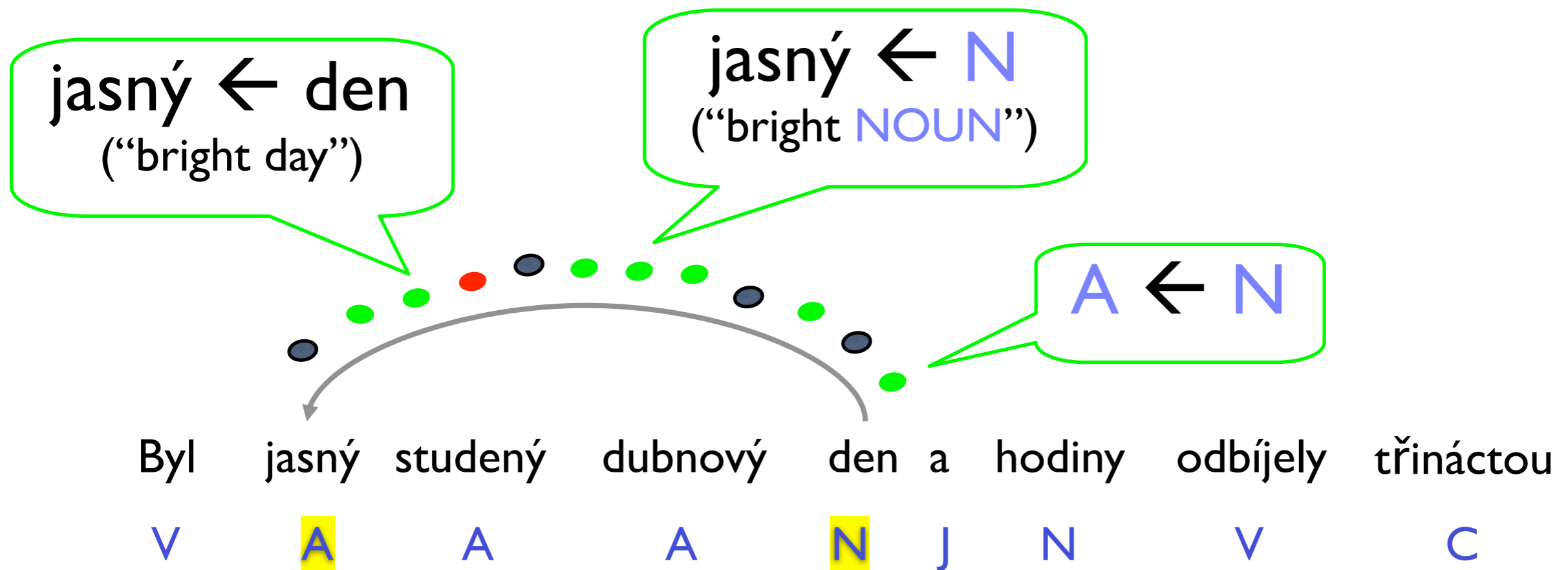

“It was a bright cold day in April and the clocks were striking thirteen”

Edge-Factored Parsers

- Is this a good edge?

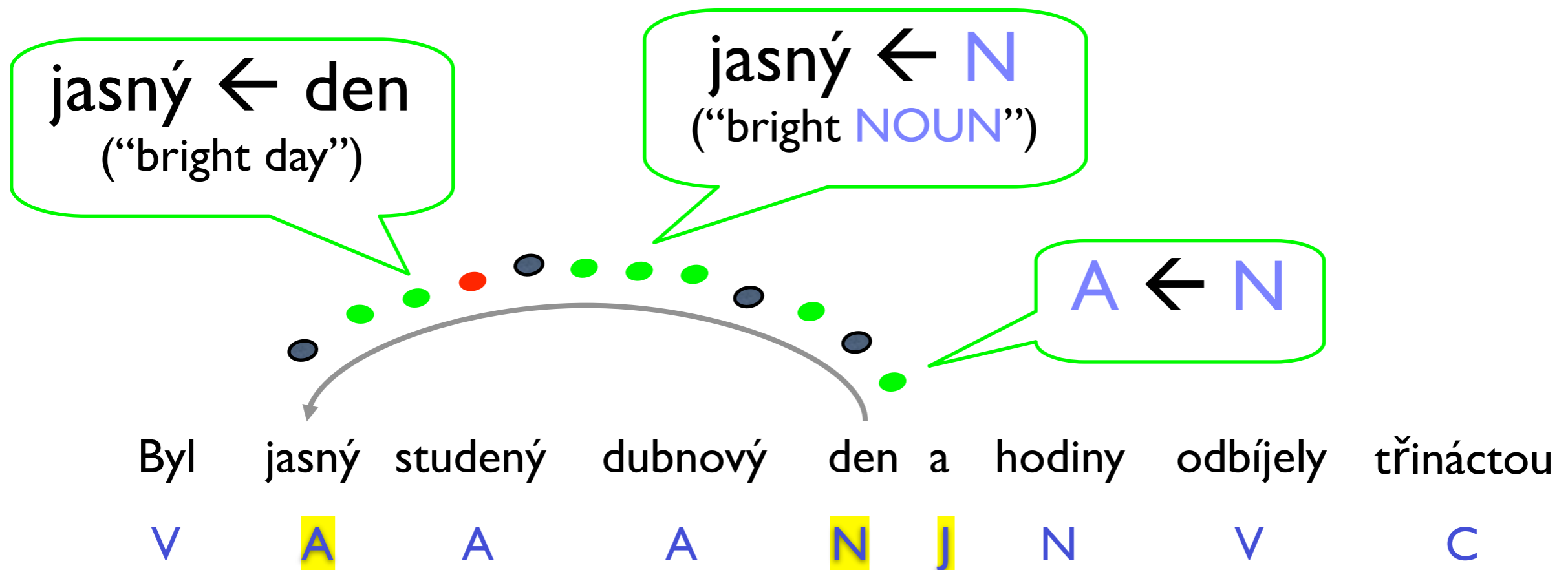

“It was a bright cold day in April and the clocks were striking thirteen”

Edge-Factored Parsers

- Is this a good edge?

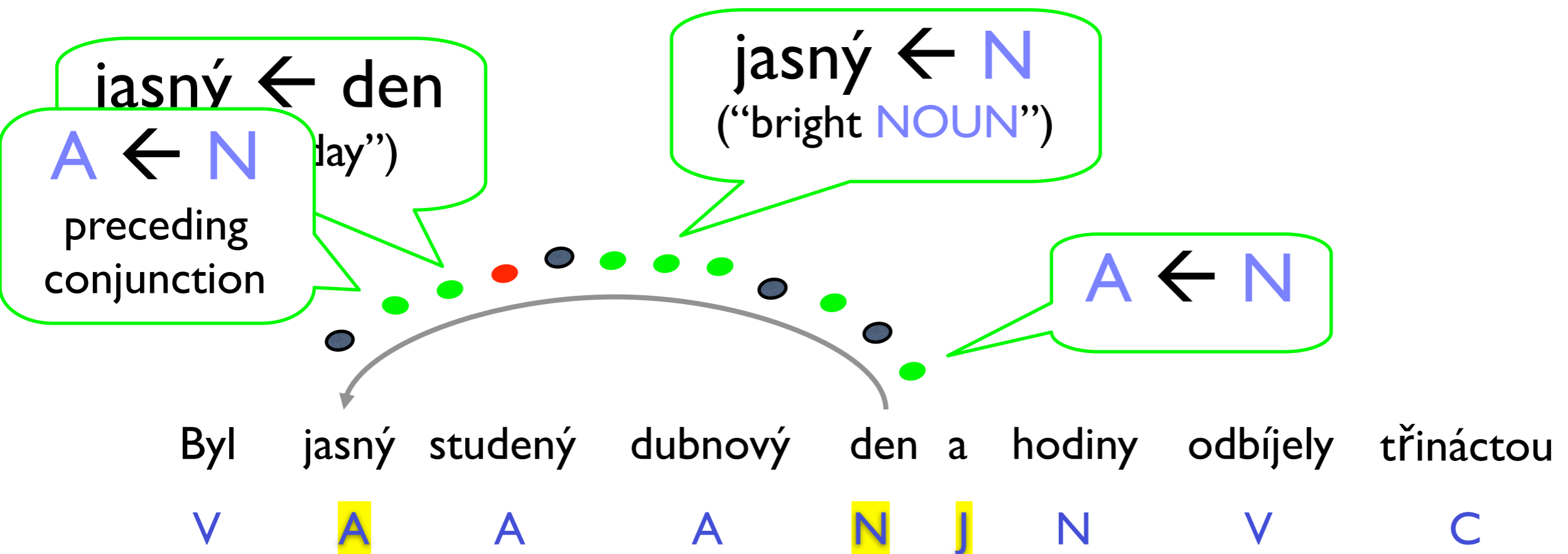

“It was a bright cold day in April and the clocks were striking thirteen”

Edge-Factored Parsers

- How about this competing edge?

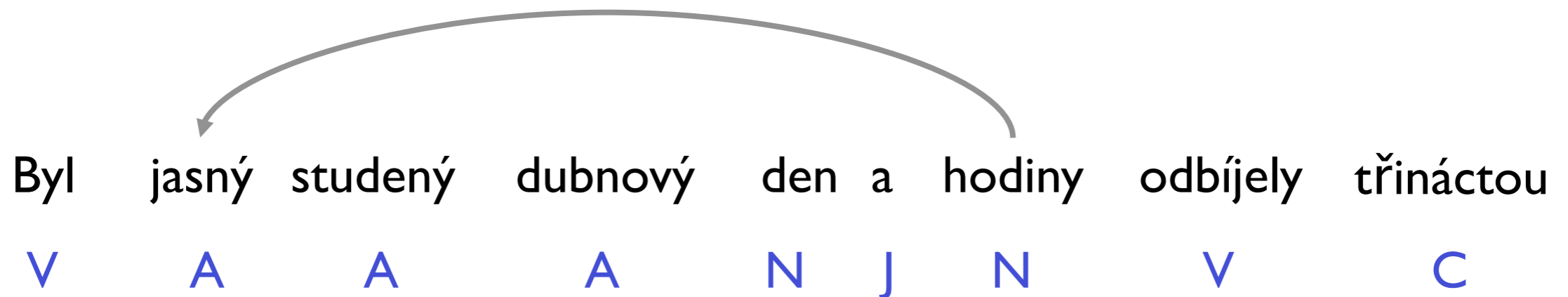

“It was a bright cold day in April and the clocks were striking thirteen”

Edge-Factored Parsers

- How about this competing edge?

not as good, lots of red ...

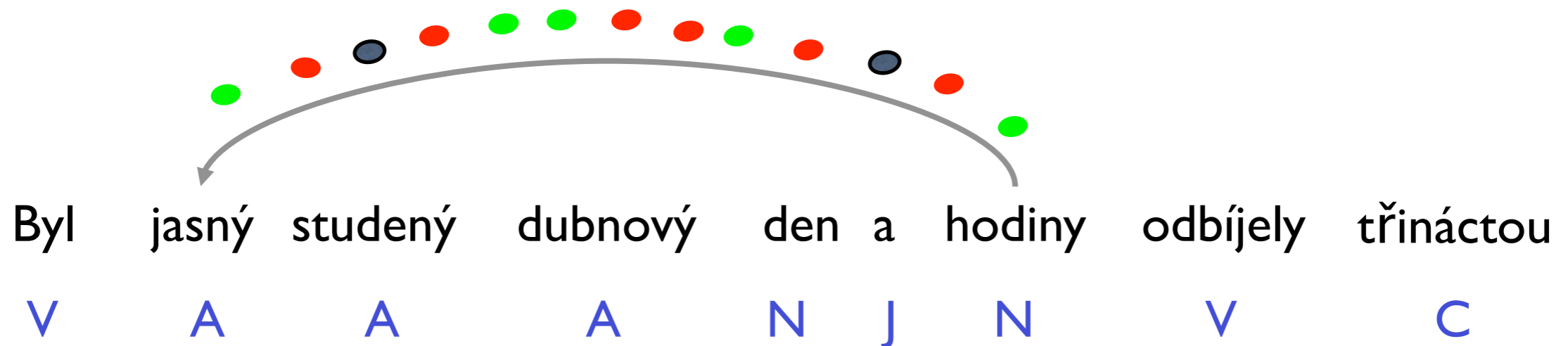

“It was a bright cold day in April and the clocks were striking thirteen”

Edge-Factored Parsers

- How about this competing edge?

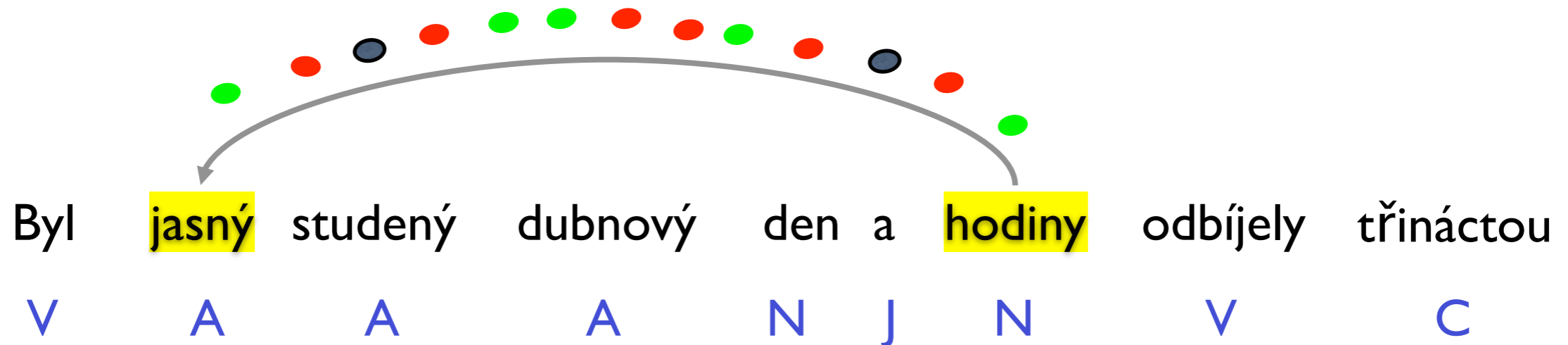

“It was a bright cold day in April and the clocks were striking thirteen”

Edge-Factored Parsers

- How about this competing edge?

jasný ← hodiny
("bright clocks")

Byl jasný studený dubnový den a hodiny odbíjely třináctou
V A A A N J N V C

“It was a bright cold day in April and the clocks were striking thirteen”

Edge-Factored Parsers

- How about this competing edge?

jasný ← hodiny
("bright clocks")

... *undertrained* ...

Byl jasný studený dubnový den a hodiny odbíjely třináctou

V

A

A

A

N

J

N

V

C

“It was a bright cold day in April and the clocks were striking thirteen”

Edge-Factored Parsers

- How about this competing edge?

jasný ← hodiny
("bright clocks")

... *undertrained* ...

Byl jasný studený dubnový den a hodiny odbíjely třináctou

V A A A N J N V C

byl jasn stud dubn den a hodi odbí třin

"It was a bright cold day in April and the clocks were striking thirteen"

Edge-Factored Parsers

- How about this competing edge?

jasný ← hodiny

(“bright clocks”)

... *undertrained* ...

jasn ← hodi

(“bright clock,”
stems only)

Byl jasný studený dubnový den a hodiny odbíjely třináctou

V A A A N J N V C

byl jasn stud dubn den a hodi odbí třin

“It was a bright cold day in April and the clocks were striking thirteen”

Edge-Factored Parsers

- How about this competing edge?

jasný ← hodiny
("bright clocks")
... *undertrained* ...

jasn ← hodi
("bright clock,"
stems only)

Byl jasný studený dubnový den a hodiny odbíjely třináctou
V A A A N J N V C
byl jasn stud dubn den a hodi odbí třin

"It was a bright cold day in April and the clocks were striking thirteen"

Edge-Factored Parsers

- How about this competing edge?

jasný ← hodiny
("bright clocks")
... *undertrained* ...

jasn ← hodi
("bright clock,"
stems only)

$A_{\text{singular}} \leftarrow N_{\text{plural}}$

Byl jasný studený dubnový den a hodiny odbíjely třináctou
V A A A N J N V C
byl jasn stud dubn den a hodi odbí třin

"It was a bright cold day in April and the clocks were striking thirteen"

Edge-Factored Parsers

- How about this competing edge?

jasný ← hodiny
("bright clocks")
... *undertrained* ...

jasn ← hodi
("bright clock,"
stems only)

A_{singular} ← N_{plural}

Byl jasný studený dubnový den a hodiny odbíjely třináctou
V A A A N J N V C
byl jasn stud dubn den a hodi odbí třin

"It was a bright cold day in April and the clocks were striking thirteen"

Edge-Factored Parsers

- How about this competing edge?

jasný ← hodiny

A ← N

where N follows
a conjunction

jasn ← hodi

(“bright clock,”
stems only)

A_{singular} ← N_{plural}

Byl jasný studený dubnový den a hodiny odbíjely třináctou

V A A A N J N V C

byl jasn stud dubn den a hodi odbí třin

“It was a bright cold day in April and the clocks were striking thirteen”

Edge-Factored Parsers

- Which edge is better?
 - “bright day” or “bright clocks”?

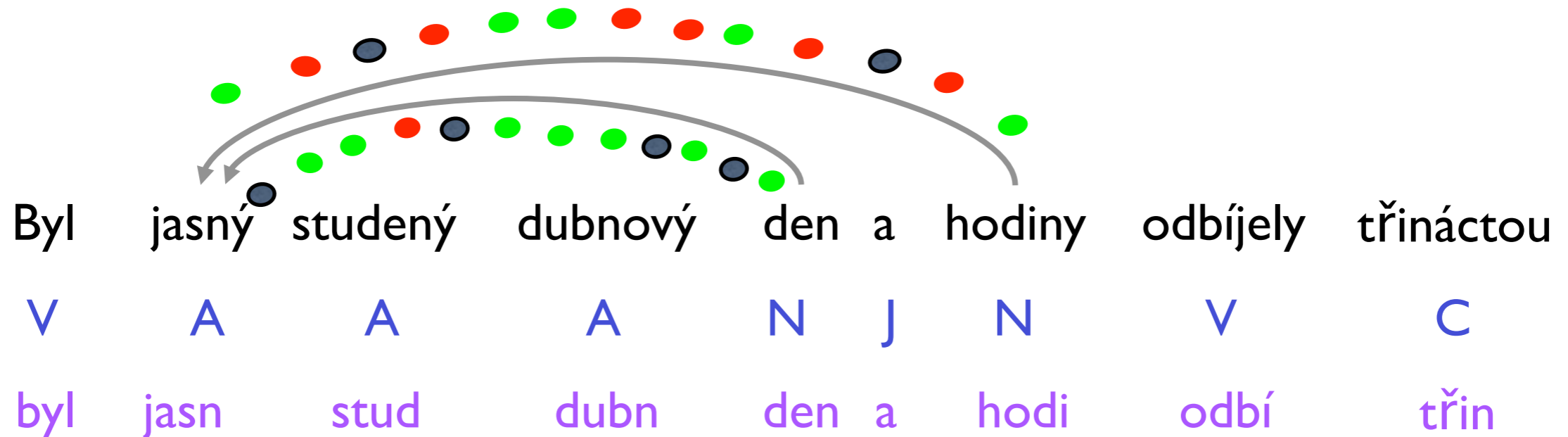

“It was a bright cold day in April and the clocks were striking thirteen”

Edge-Factored Parsers

- Which edge is better?
- Score of an edge $e = \theta \cdot \mathbf{features}(e)$
- Standard algos \rightarrow valid parse with max total score

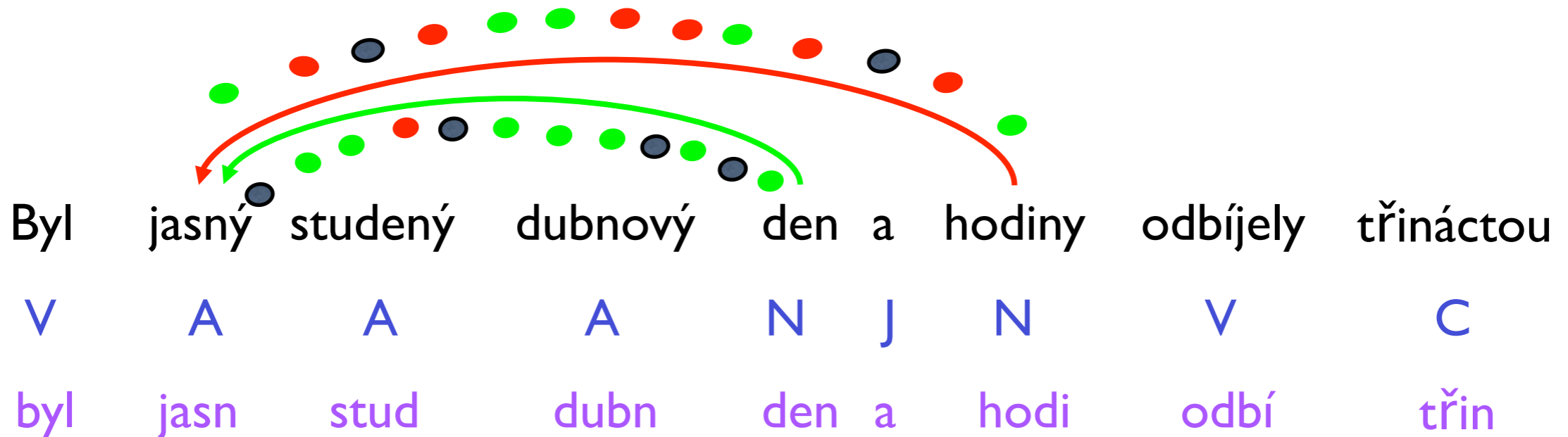

“It was a bright cold day in April and the clocks were striking thirteen”

Edge-Factored Parsers

- Which edge is better? *our current weight vector*
- Score of an edge $e = \theta \cdot \text{features}(e)$
- Standard algos \rightarrow valid parse with max total score

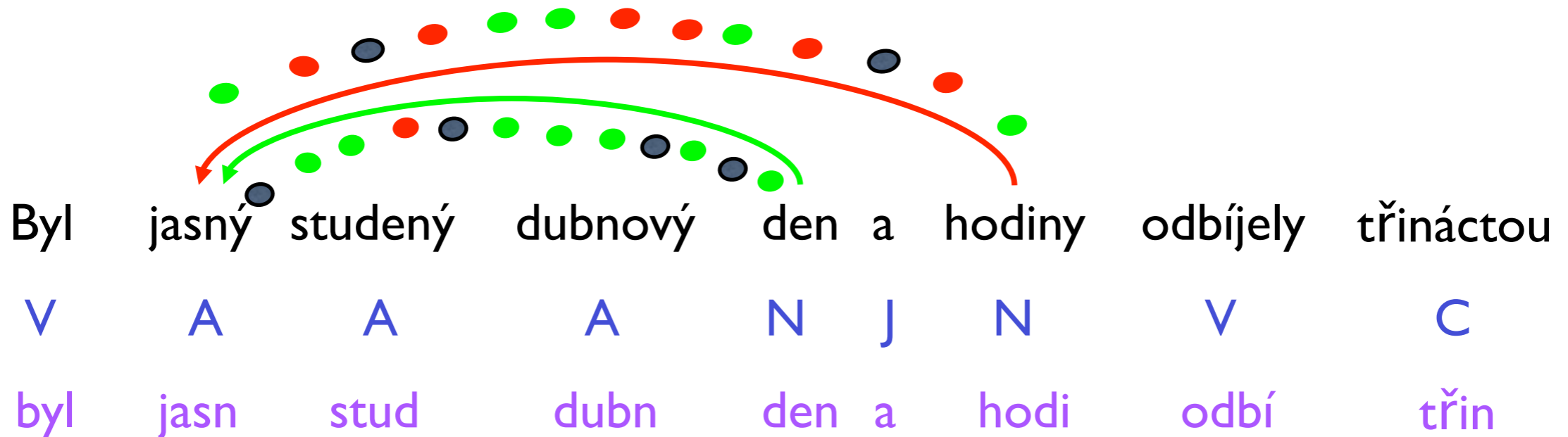

“It was a bright cold day in April and the clocks were striking thirteen”

Local factors in a graphical model

- First, a familiar example
 - Conditional Random Field (CRF) for POS tagging

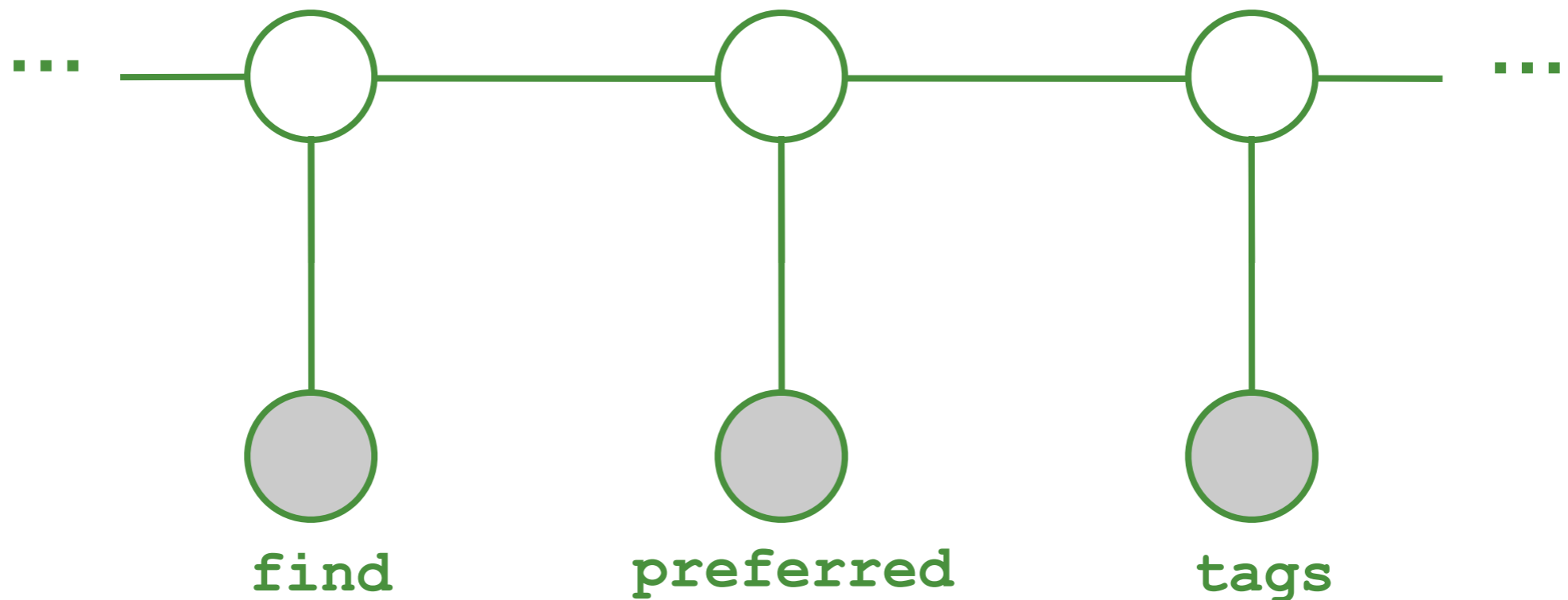

Local factors in a graphical model

- First, a familiar example
 - Conditional Random Field (CRF) for POS tagging

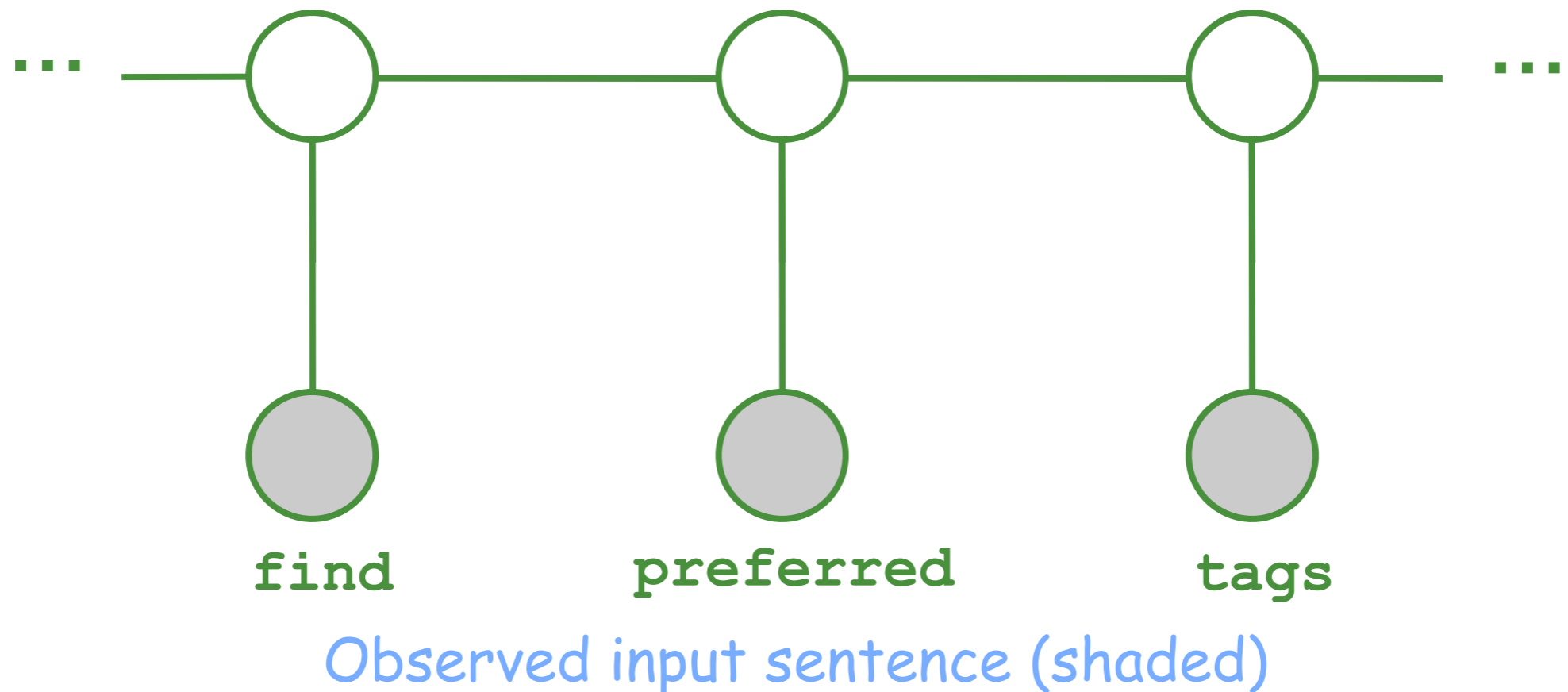

Local factors in a graphical model

- First, a familiar example
 - Conditional Random Field (CRF) for POS tagging

Possible tagging (i.e., assignment to remaining variables)

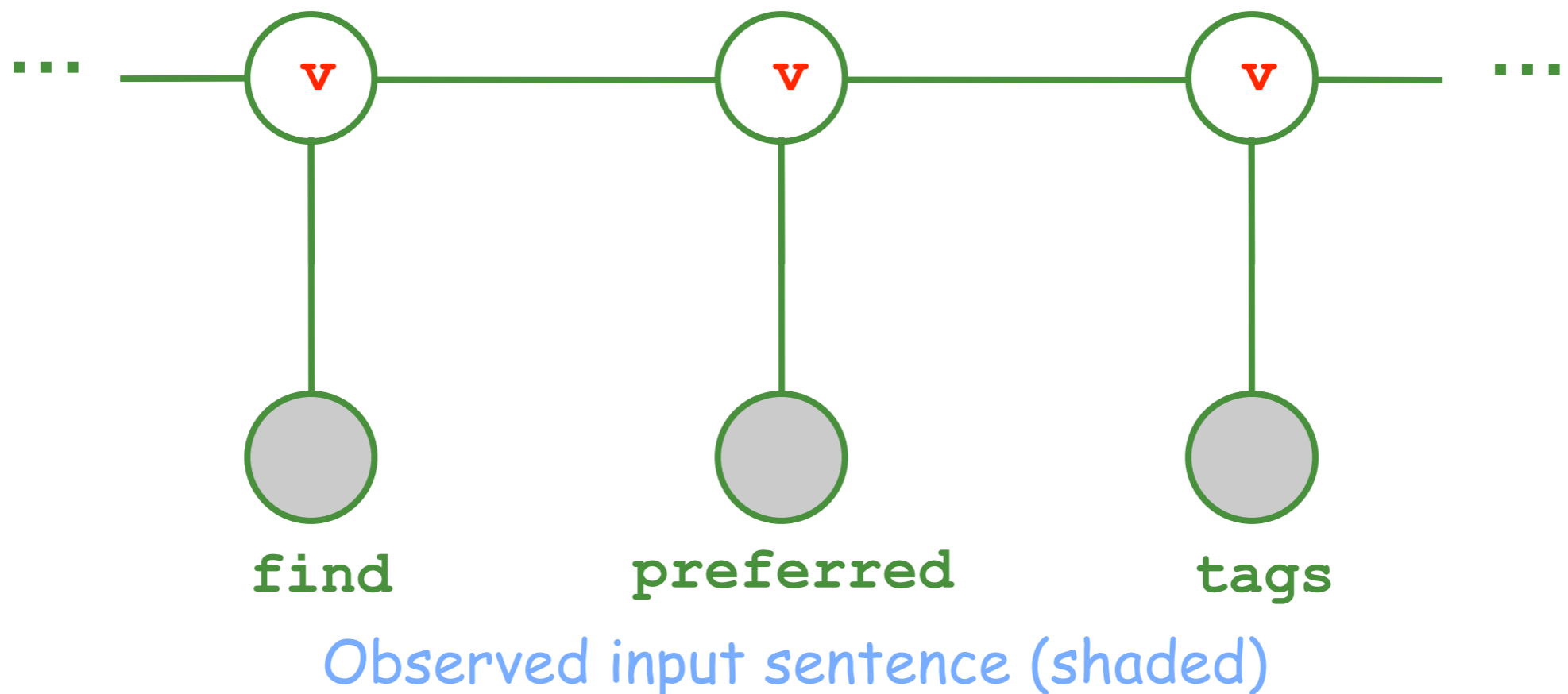

Local factors in a graphical model

- First, a familiar example
 - Conditional Random Field (CRF) for POS tagging

Possible tagging (i.e., assignment to remaining variables)
Another possible tagging

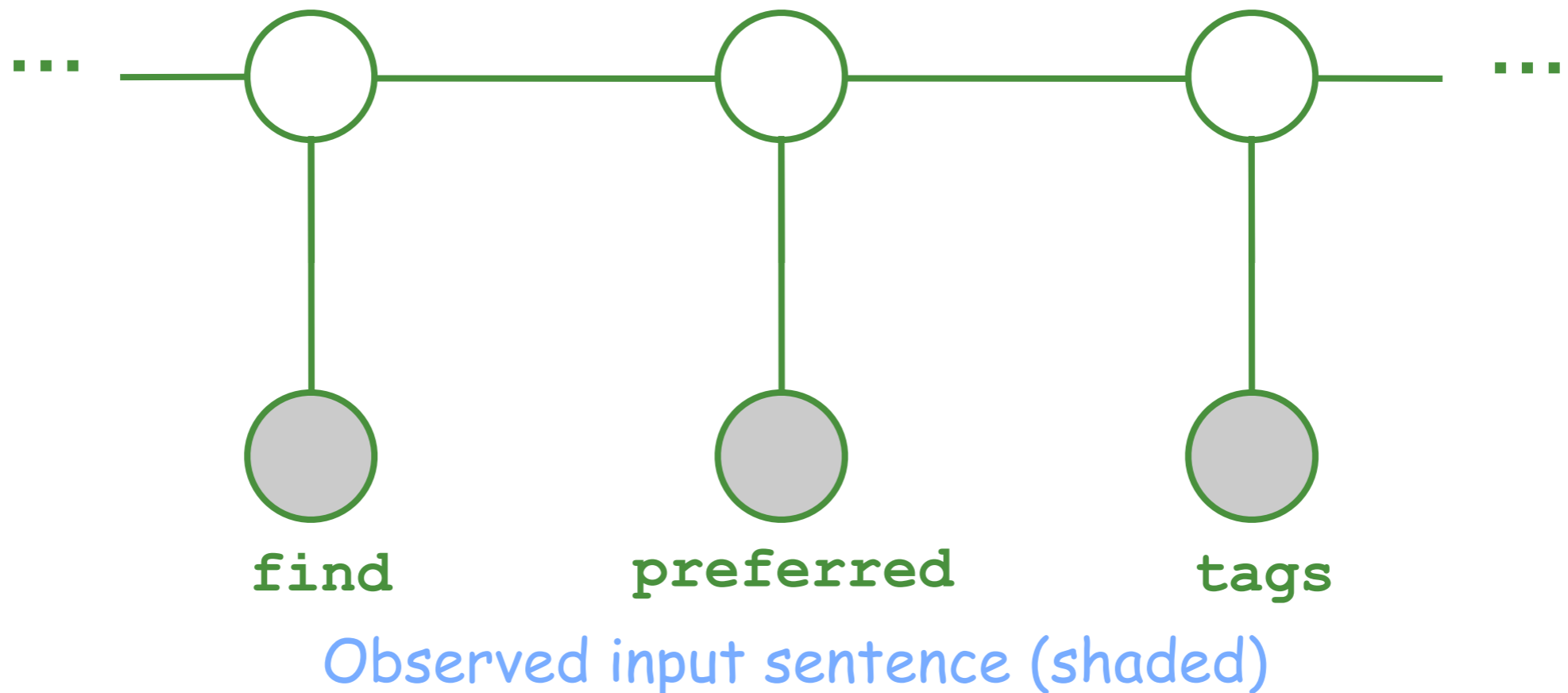

Local factors in a graphical model

- First, a familiar example
 - Conditional Random Field (CRF) for POS tagging

Possible tagging (i.e., assignment to remaining variables)
Another possible tagging

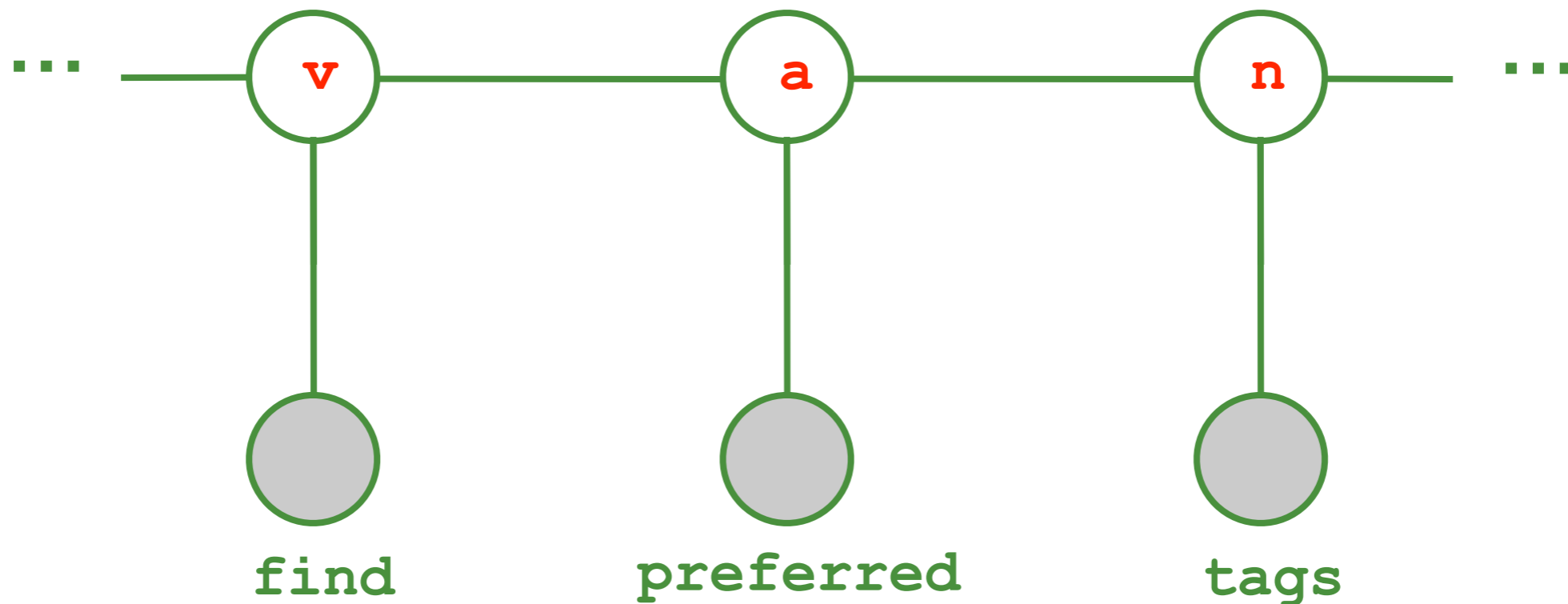

Observed input sentence (shaded)

Local factors in a graphical model

- First, a familiar example
 - Conditional Random Field (CRF) for POS tagging

"Binary" factor
that measures
compatibility of 2
adjacent tags

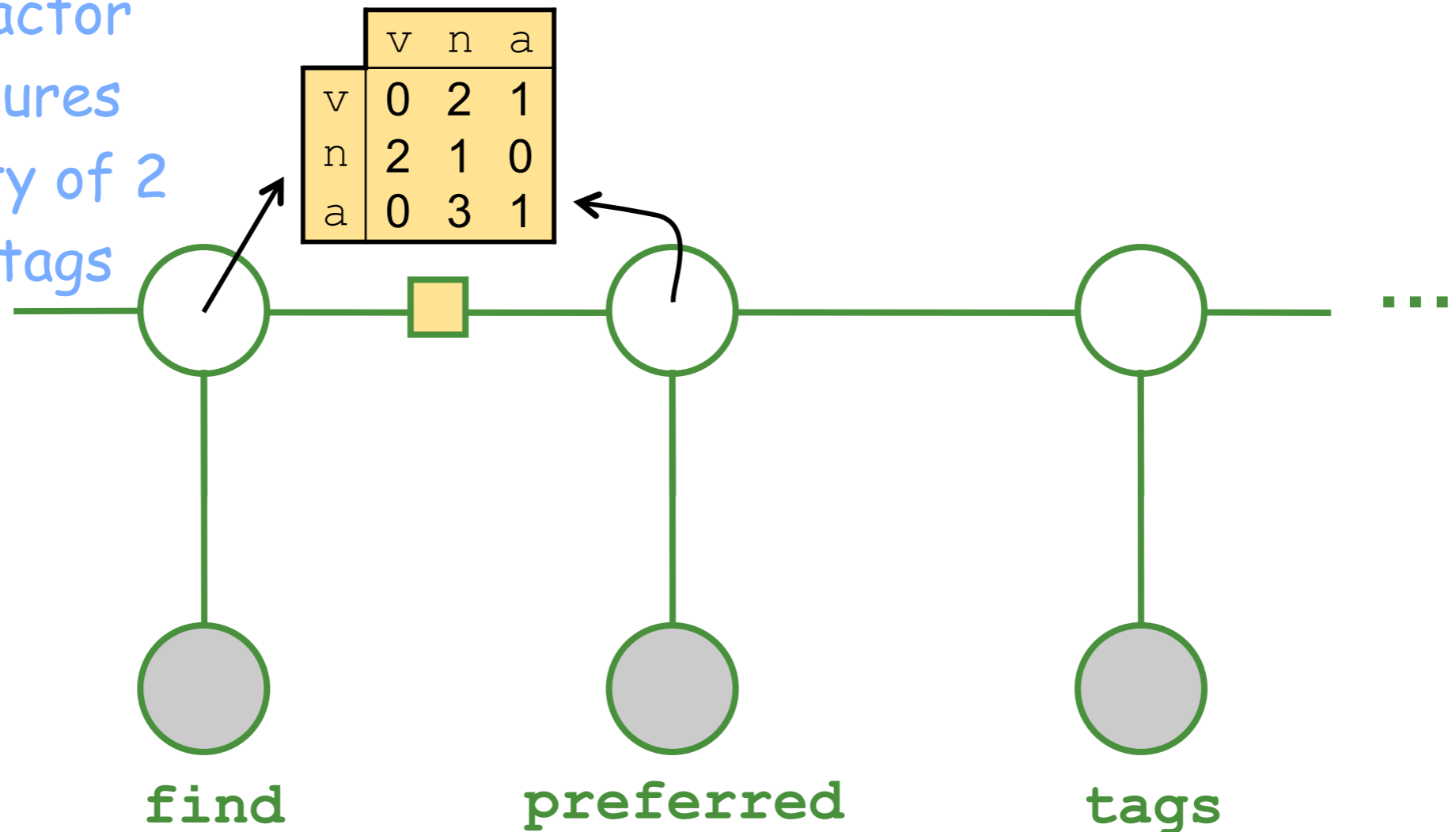

Local factors in a graphical model

- First, a familiar example
 - Conditional Random Field (CRF) for POS tagging

"Binary" factor
that measures
compatibility of 2
adjacent tags

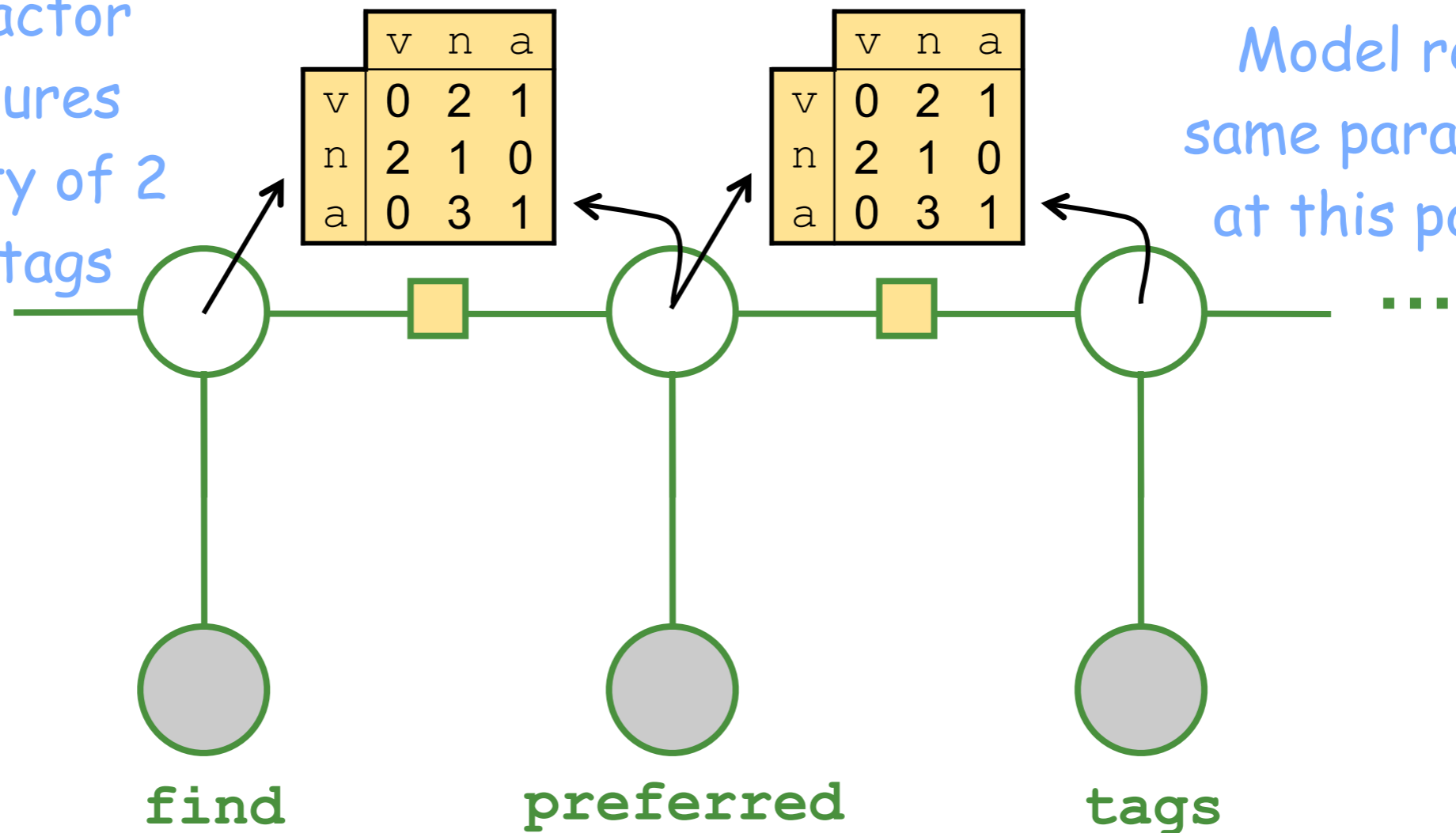

Model reuses
same parameters
at this position

Local factors in a graphical model

- First, a familiar example
 - Conditional Random Field (CRF) for POS tagging

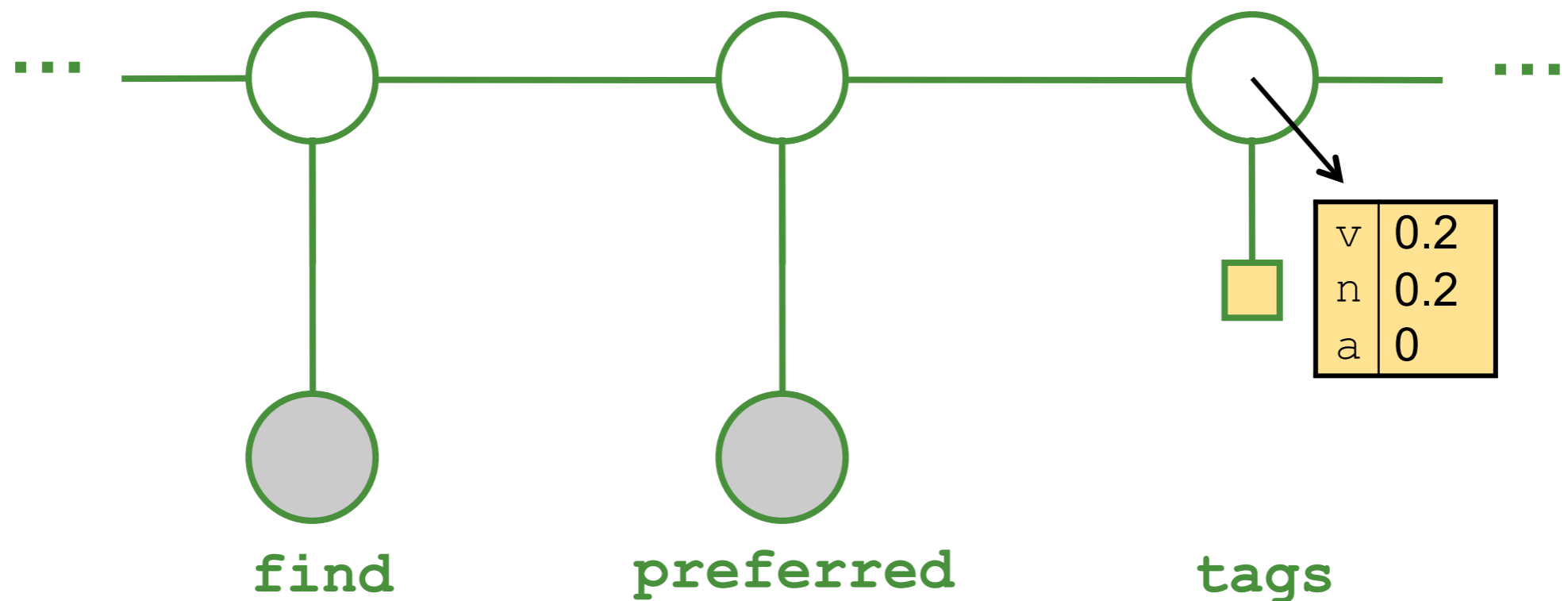

Local factors in a graphical model

- First, a familiar example
 - Conditional Random Field (CRF) for POS tagging

“Unary” factor evaluates this tag

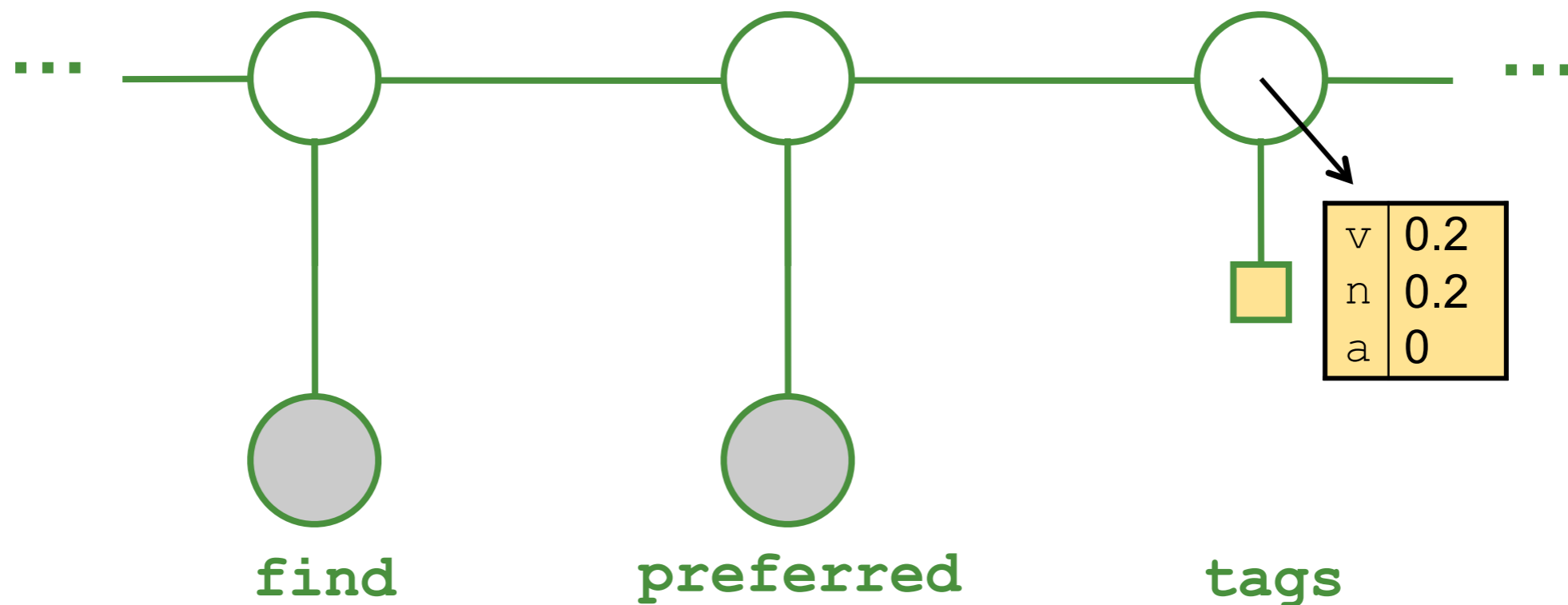

Local factors in a graphical model

- First, a familiar example
 - Conditional Random Field (CRF) for POS tagging

“Unary” factor evaluates this tag
Its values depend on corresponding word

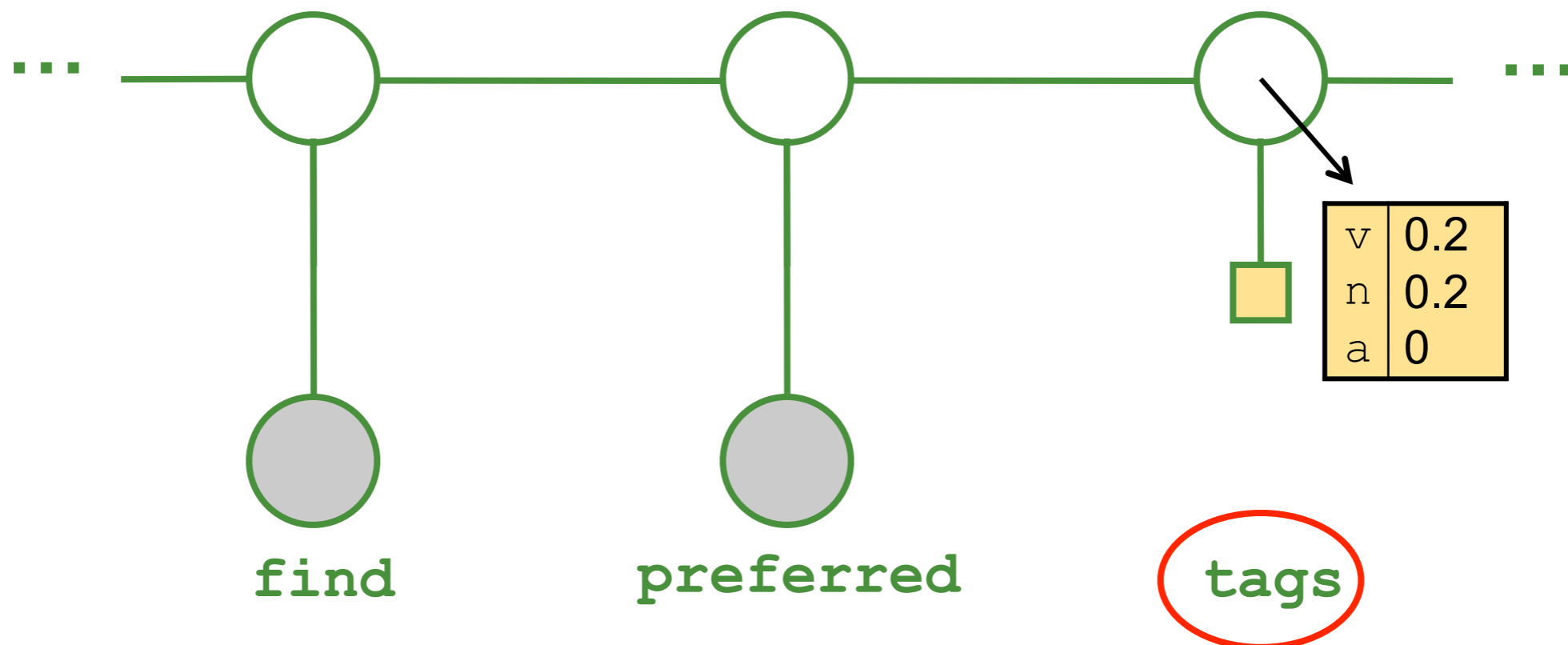

Local factors in a graphical model

- First, a familiar example
 - Conditional Random Field (CRF) for POS tagging

“Unary” factor evaluates this tag
Its values depend on corresponding word

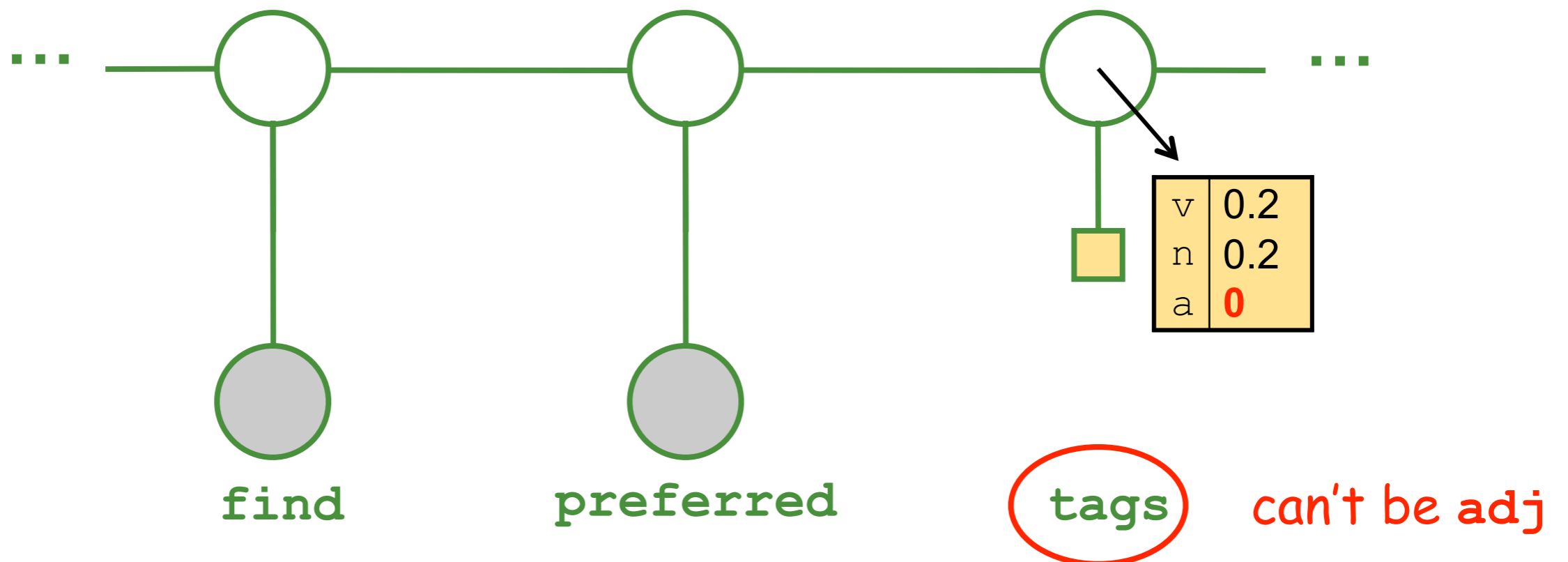

Local factors in a graphical model

- First, a familiar example
 - Conditional Random Field (CRF) for POS tagging

“Unary” factor evaluates this tag
Its values depend on corresponding word

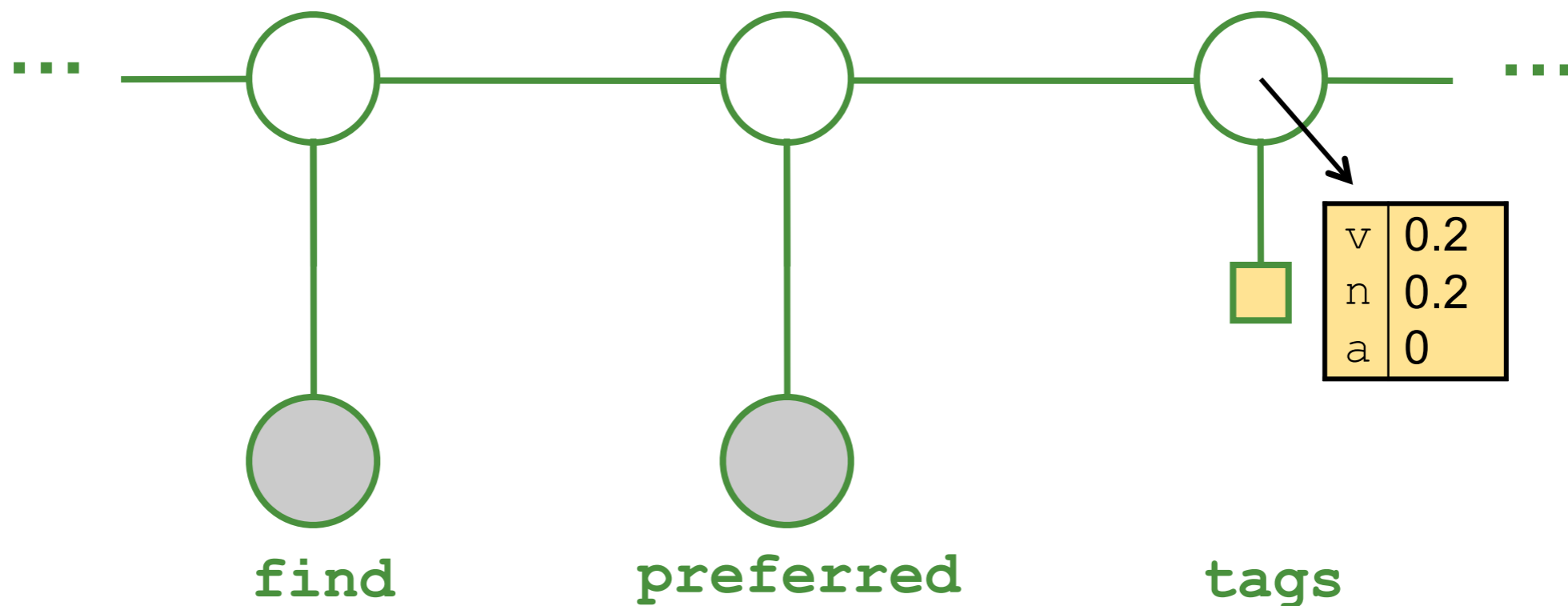

Local factors in a graphical model

- First, a familiar example
 - Conditional Random Field (CRF) for POS tagging

“Unary” factor evaluates this tag
Its values depend on corresponding word

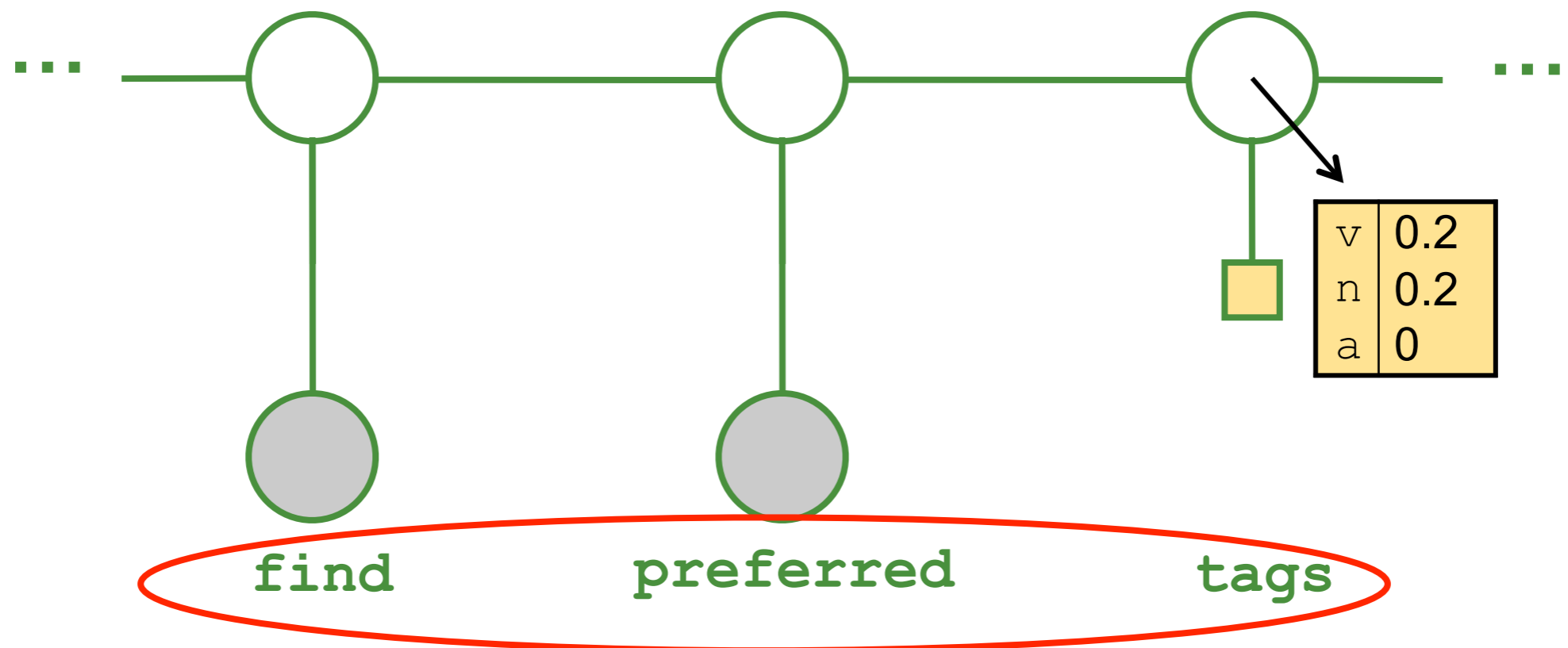

(could be made to depend on entire observed sentence)

Local factors in a graphical model

- First, a familiar example
 - Conditional Random Field (CRF) for POS tagging

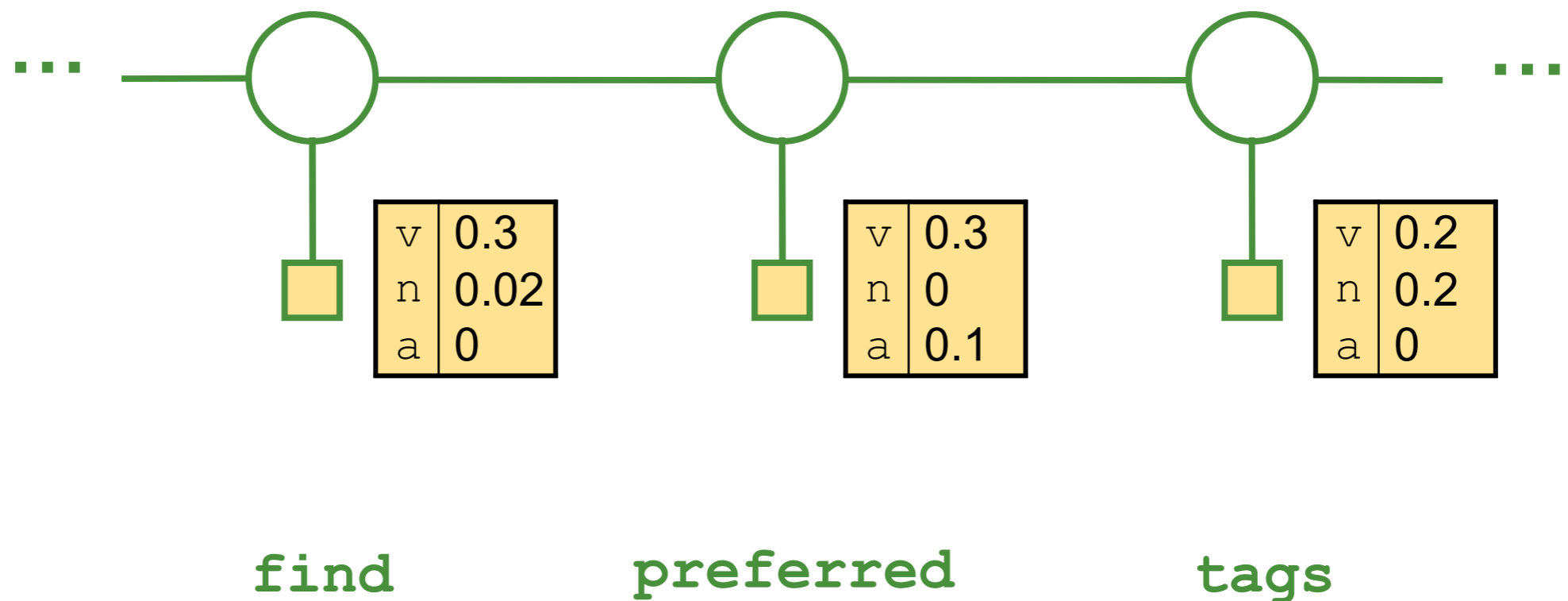

Local factors in a graphical model

- First, a familiar example
 - Conditional Random Field (CRF) for POS tagging

“Unary” factor evaluates this tag
Different unary factor at each position

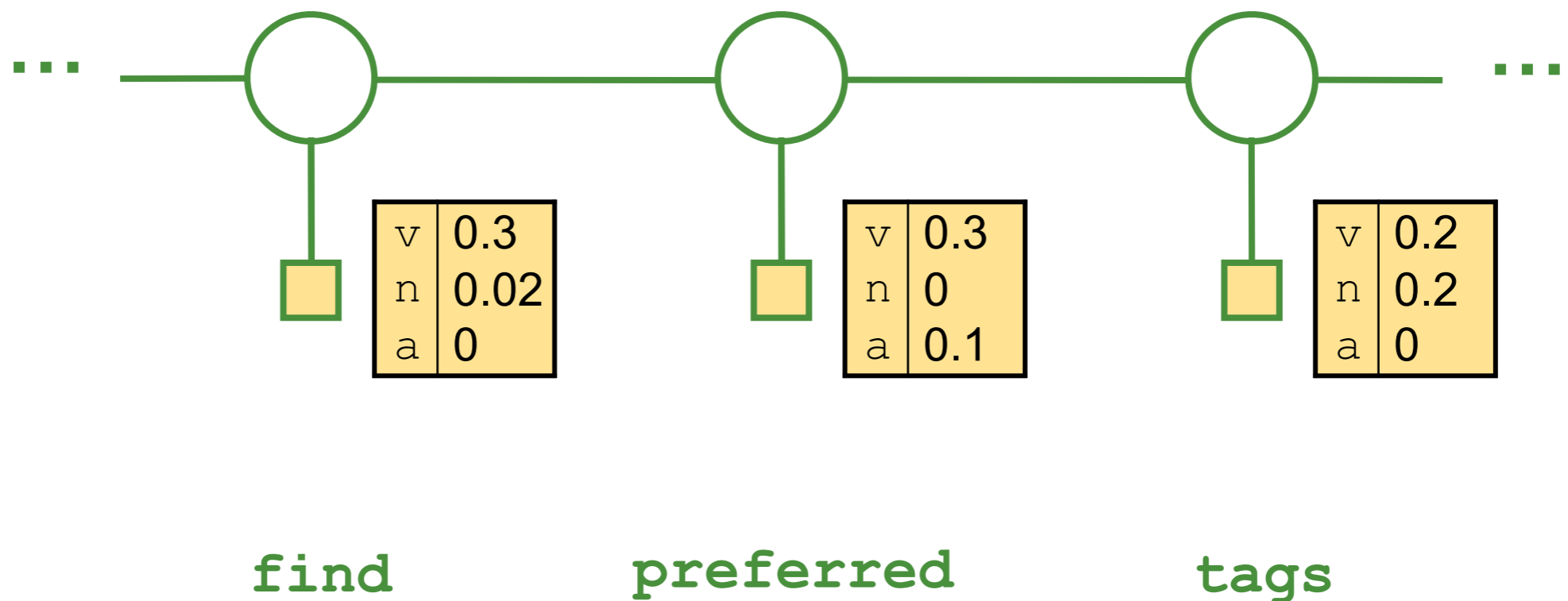

Local factors in a graphical model

- First, a familiar example
 - Conditional Random Field (CRF) for POS tagging

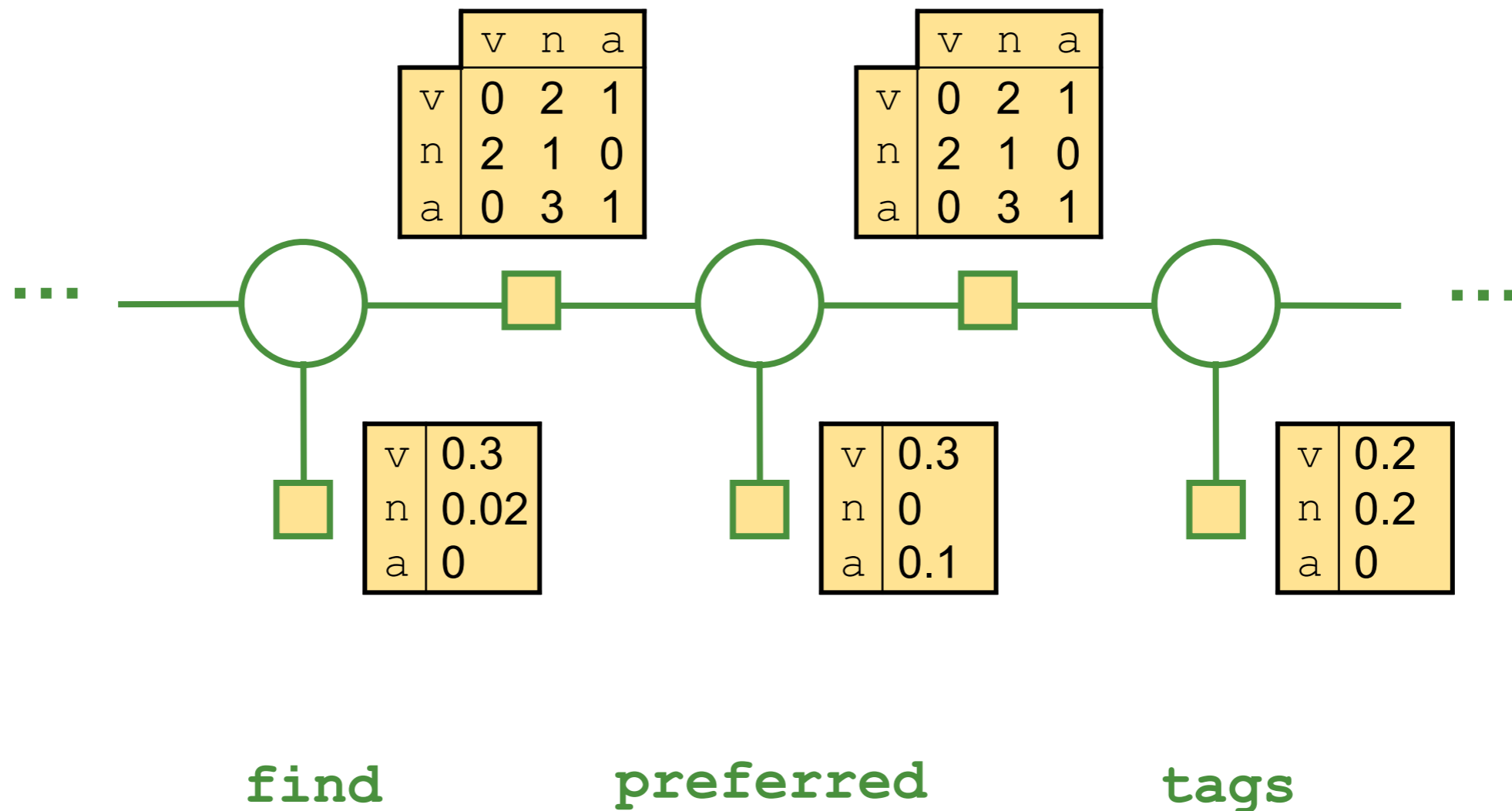

Local factors in a graphical model

- First, a familiar example
 - Conditional Random Field (CRF) for POS tagging

$p(\mathbf{v} \ \mathbf{a} \ \mathbf{n})$ is proportional to the product of all factors' values on $\mathbf{v} \ \mathbf{a} \ \mathbf{n}$

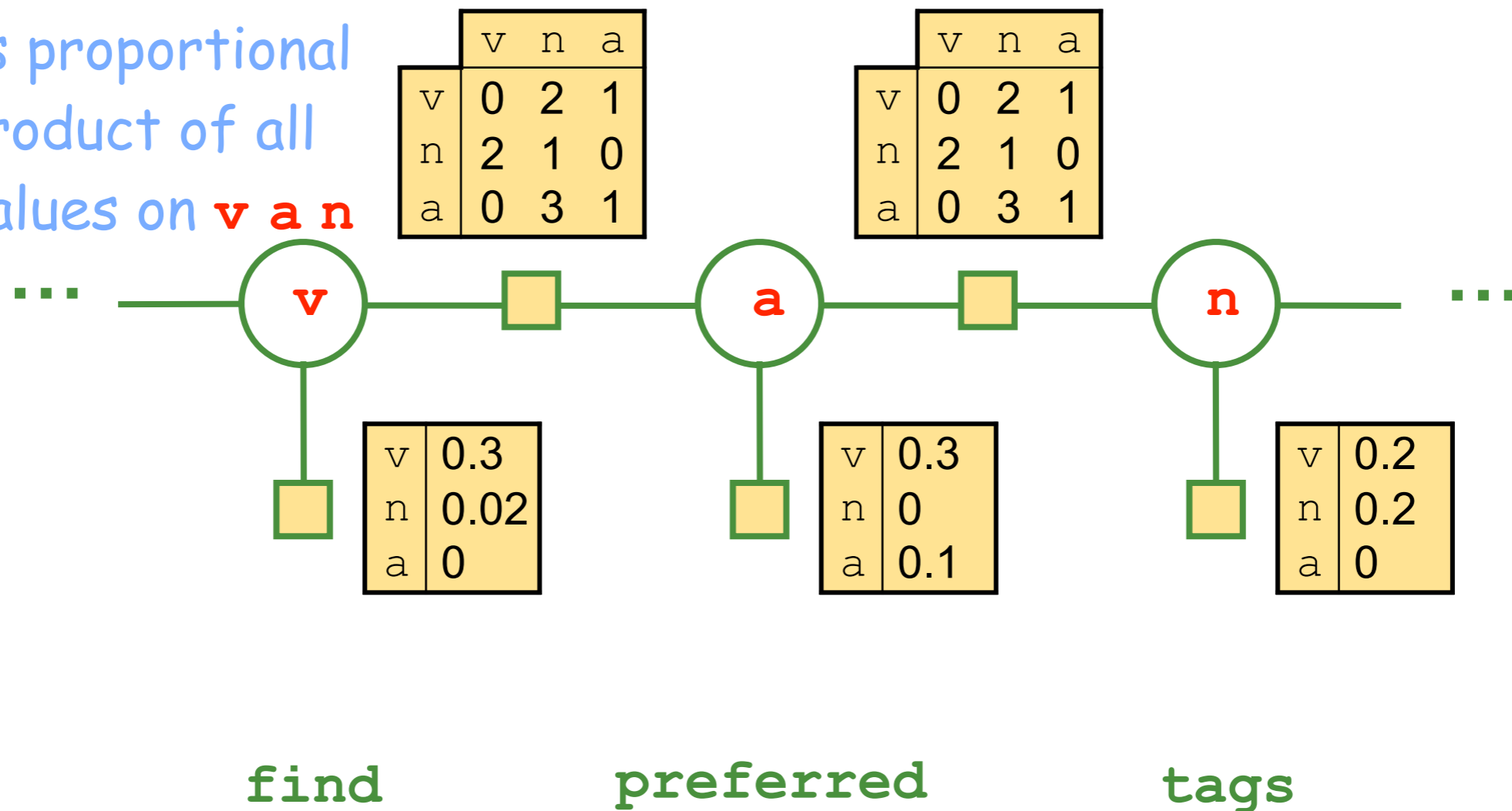

Local factors in a graphical model

- First, a familiar example
 - Conditional Random Field (CRF) for POS tagging

$p(\mathbf{v} \ \mathbf{a} \ \mathbf{n})$ is proportional to the product of all factors' values on $\mathbf{v} \ \mathbf{a} \ \mathbf{n}$

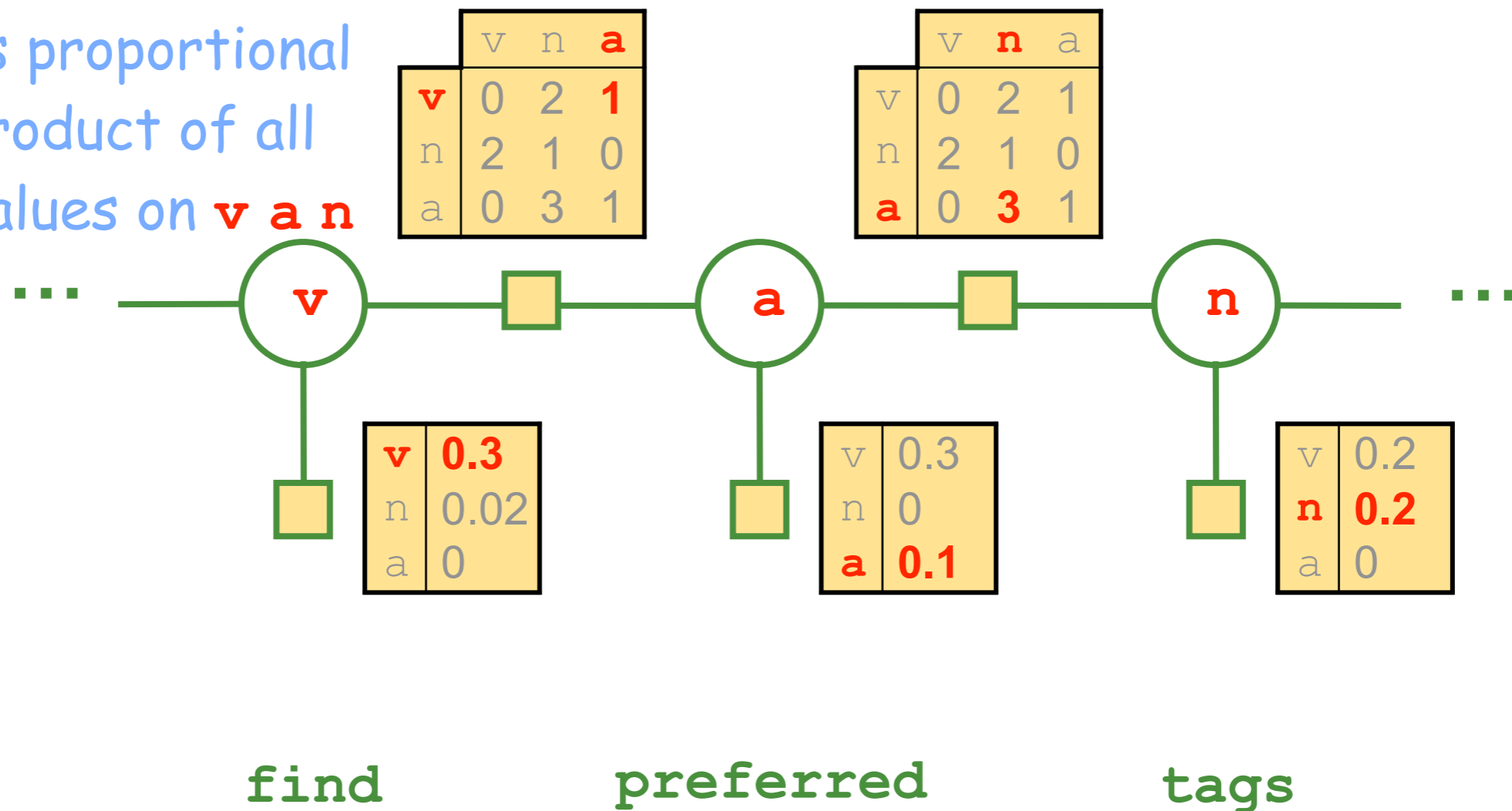

Local factors in a graphical model

- First, a familiar example
 - Conditional Random Field (CRF) for POS tagging

$p(\mathbf{v} \ \mathbf{a} \ \mathbf{n})$ is proportional to the product of all factors' values on $\mathbf{v} \ \mathbf{a} \ \mathbf{n}$

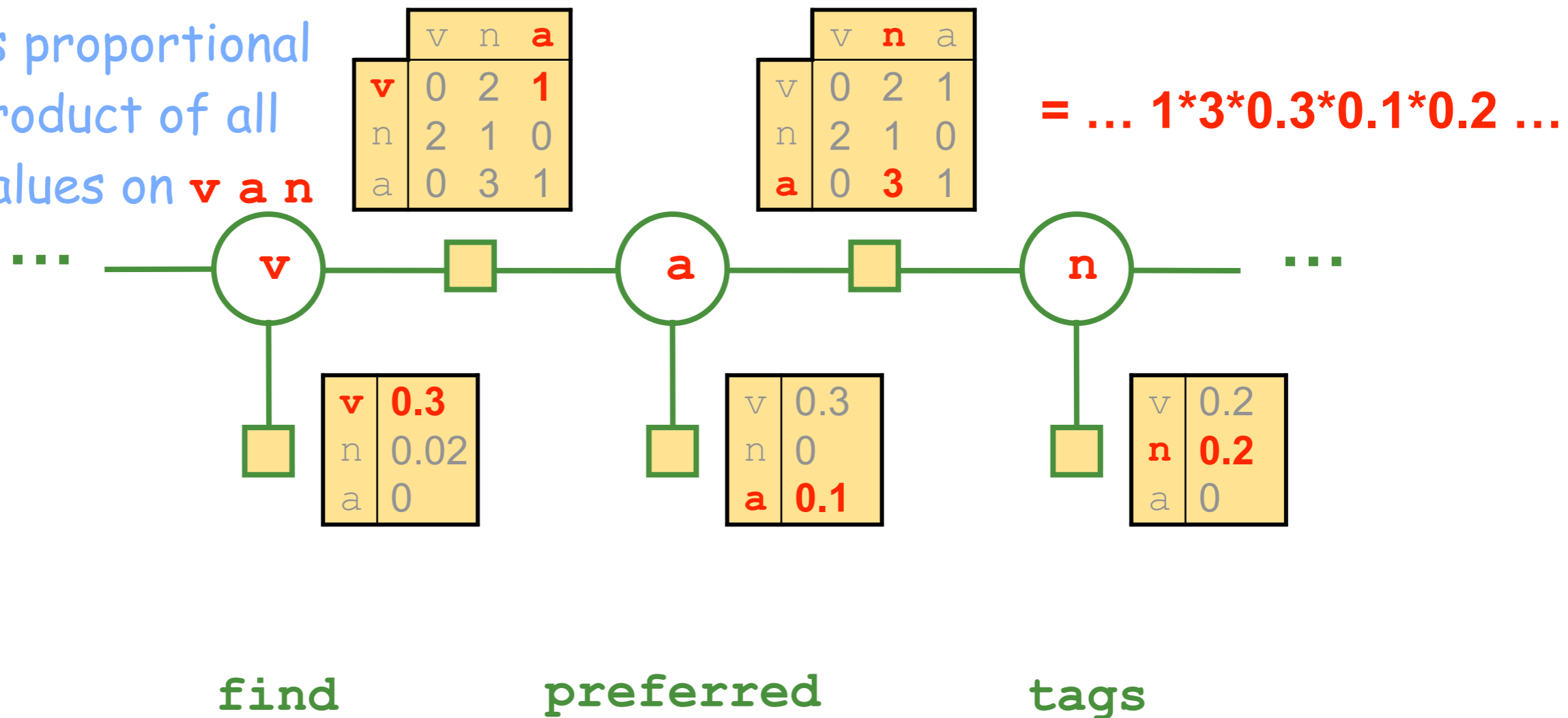

Graphical Models for Parsing

- First, a labeling example

- ❖ CRF for POS tagging

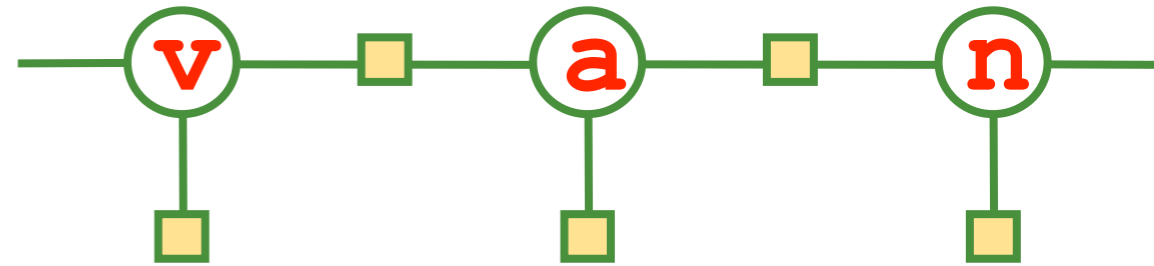

- Now let's do dependency parsing!

- ❖ $O(n^2)$ boolean variables for the possible links

... find preferred links ...

Graphical Models for Parsing

- First, a labeling example

- ❖ CRF for POS tagging

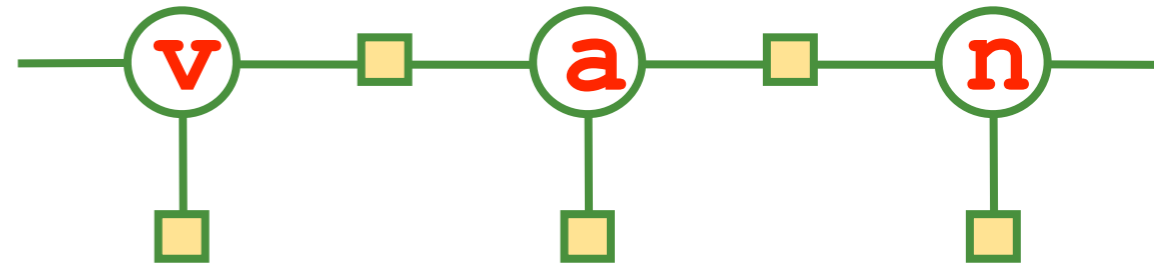

- Now let's do dependency parsing!

- ❖ $O(n^2)$ boolean variables for the possible links

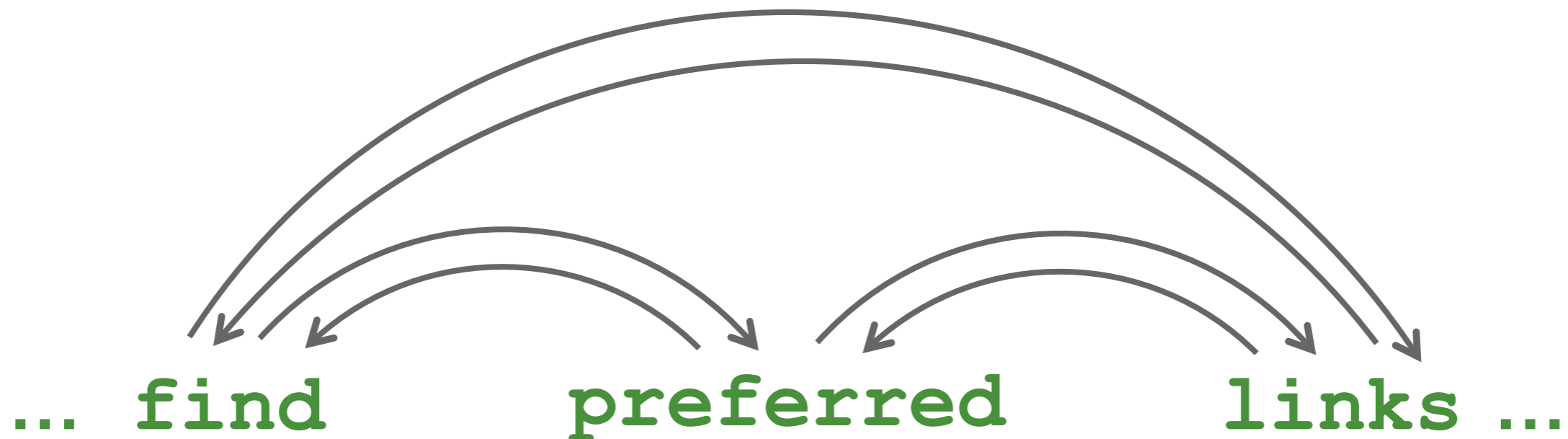

Graphical Models for Parsing

- First, a labeling example

- ❖ CRF for POS tagging

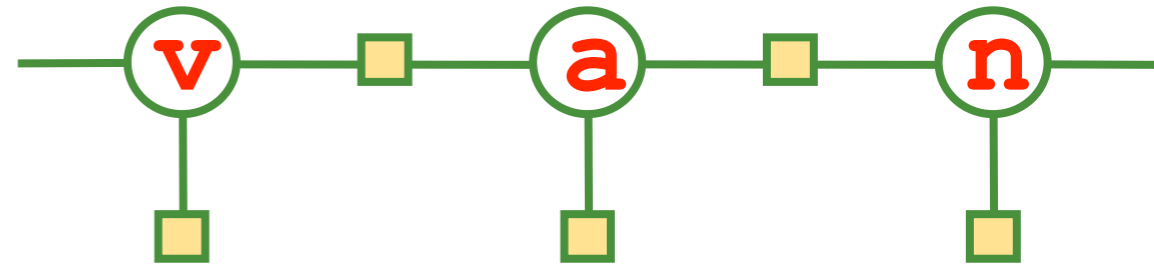

- Now let's do dependency parsing!

- ❖ $O(n^2)$ boolean variables for the possible links

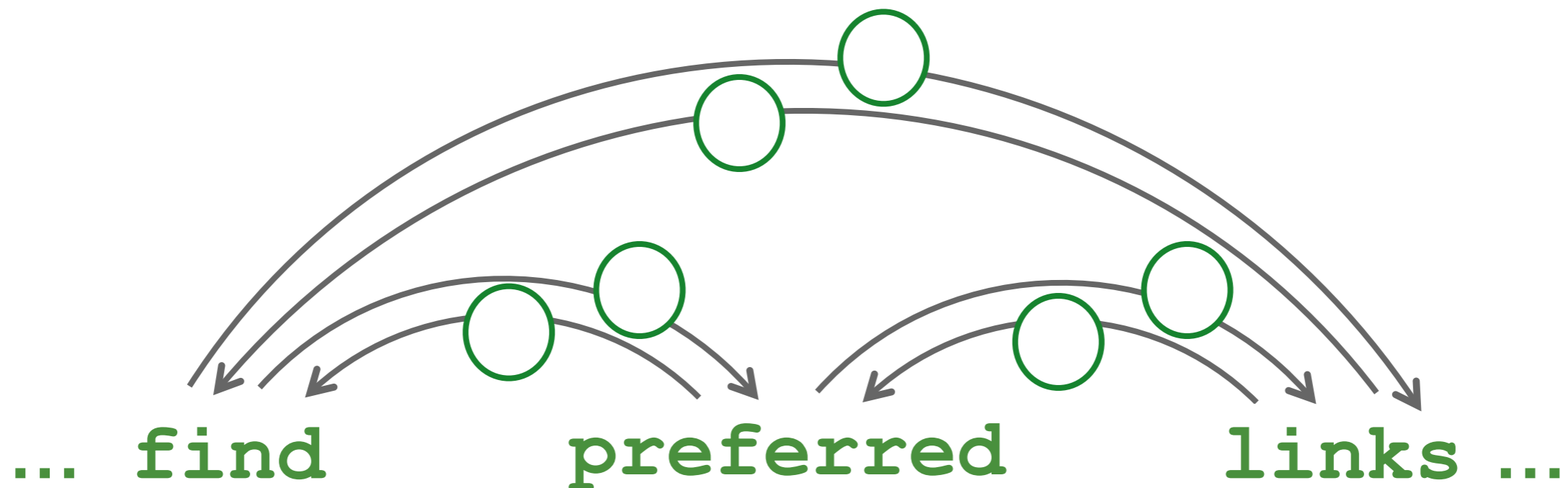

Graphical Models for Parsing

- First, a labeling example

- ❖ CRF for POS tagging

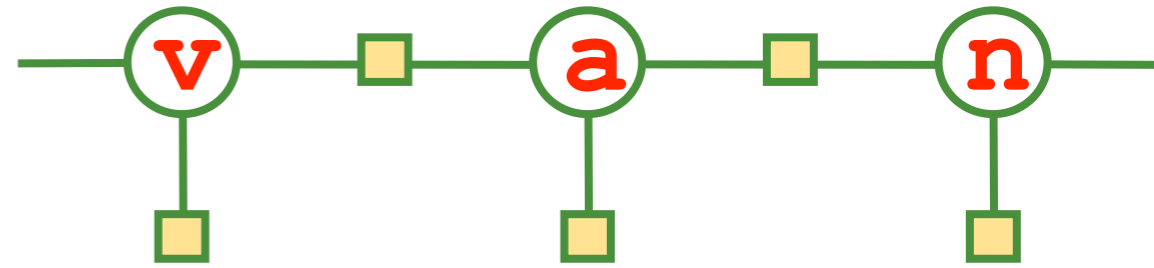

- Now let's do dependency parsing!

- ❖ $O(n^2)$ boolean variables for the possible links

*Possible
parse...*

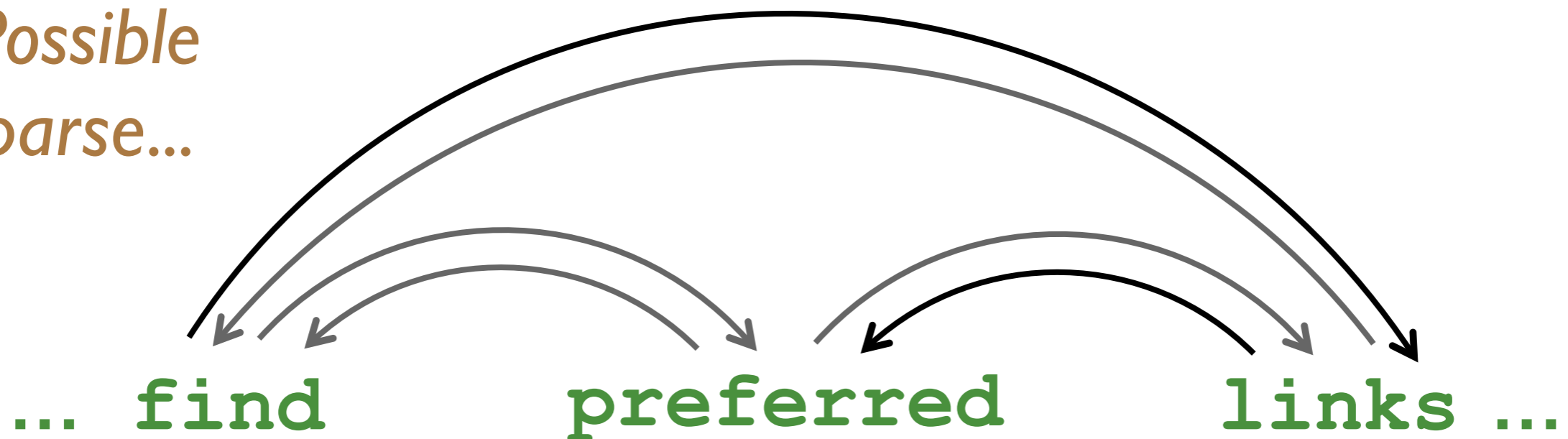

Graphical Models for Parsing

- First, a labeling example

- ❖ CRF for POS tagging

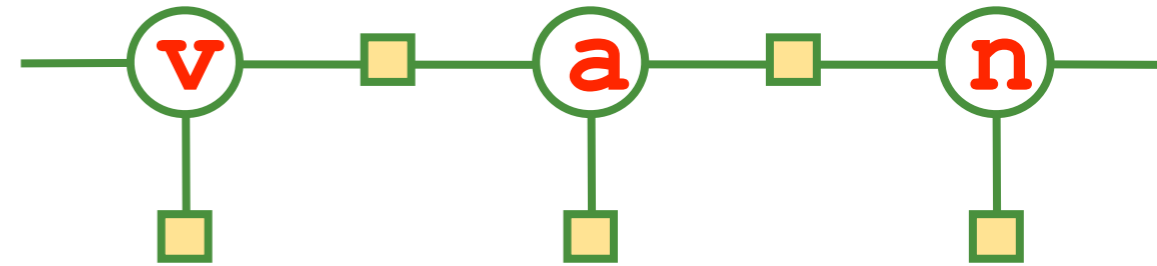

- Now let's do dependency parsing!

- ❖ $O(n^2)$ boolean variables for the possible links

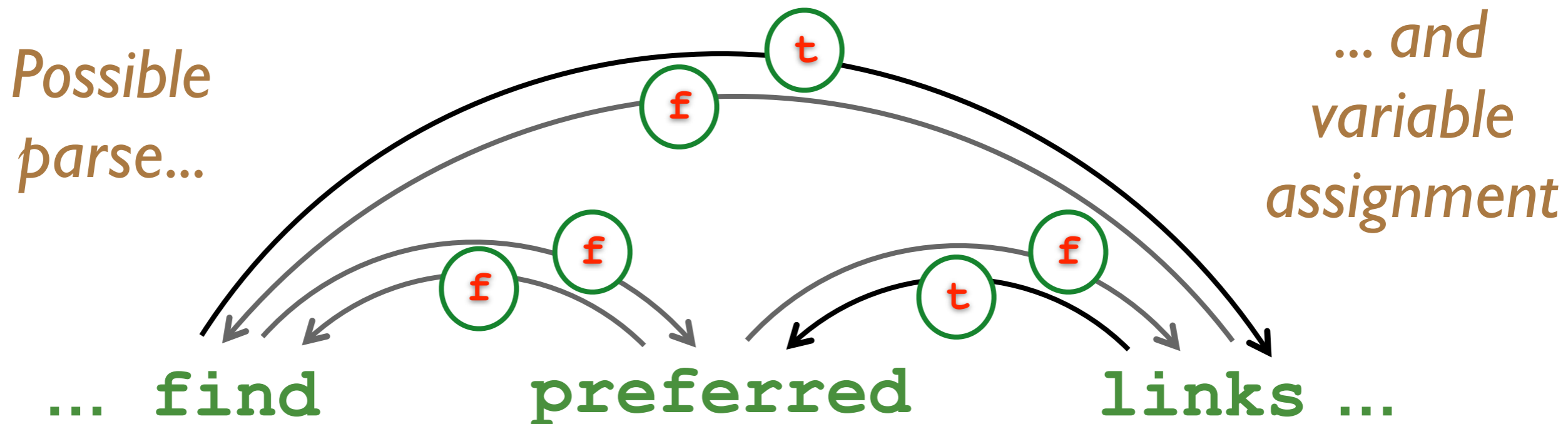

Graphical Models for Parsing

- First, a labeling example

- ❖ CRF for POS tagging

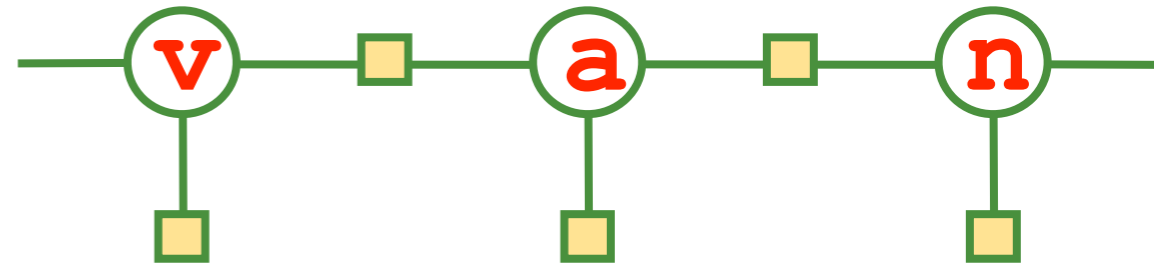

- Now let's do dependency parsing!

- ❖ $O(n^2)$ boolean variables for the possible links

*Another
parse...*

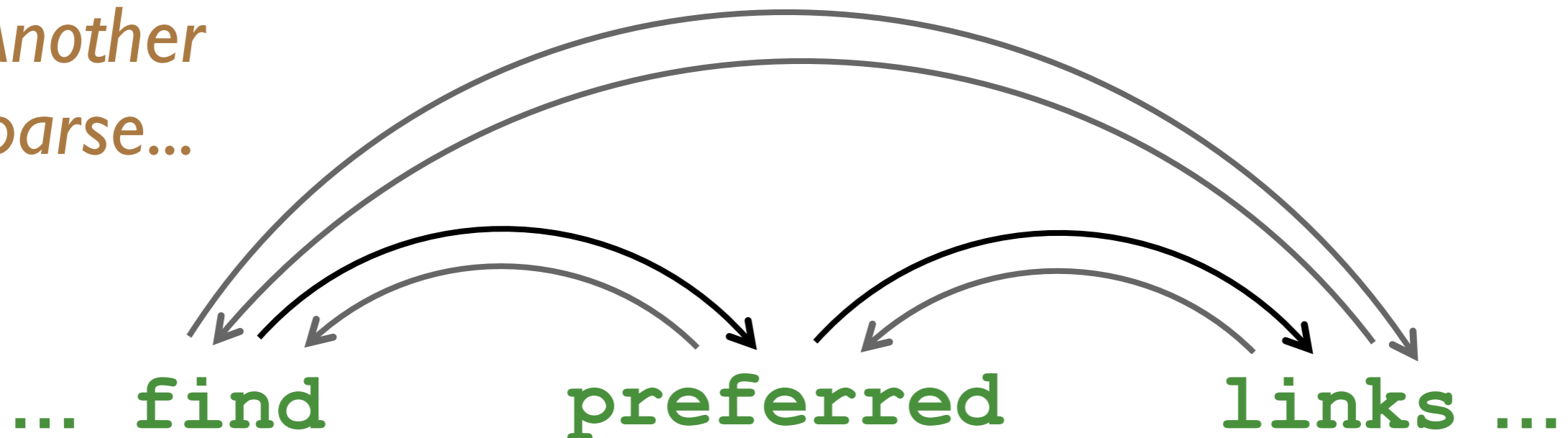

Graphical Models for Parsing

- First, a labeling example

- ❖ CRF for POS tagging

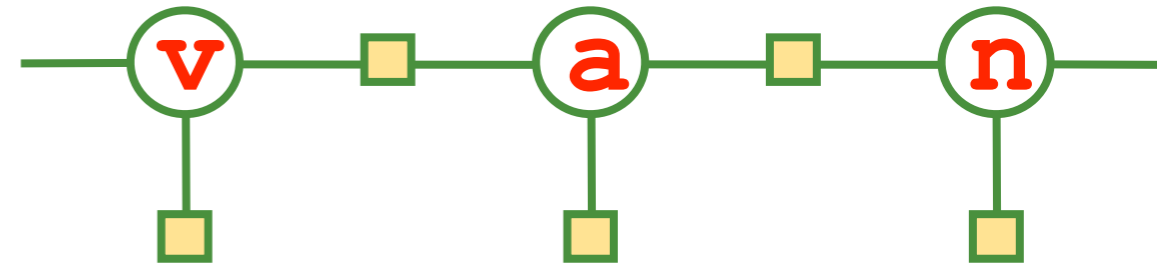

- Now let's do dependency parsing!

- ❖ $O(n^2)$ boolean variables for the possible links

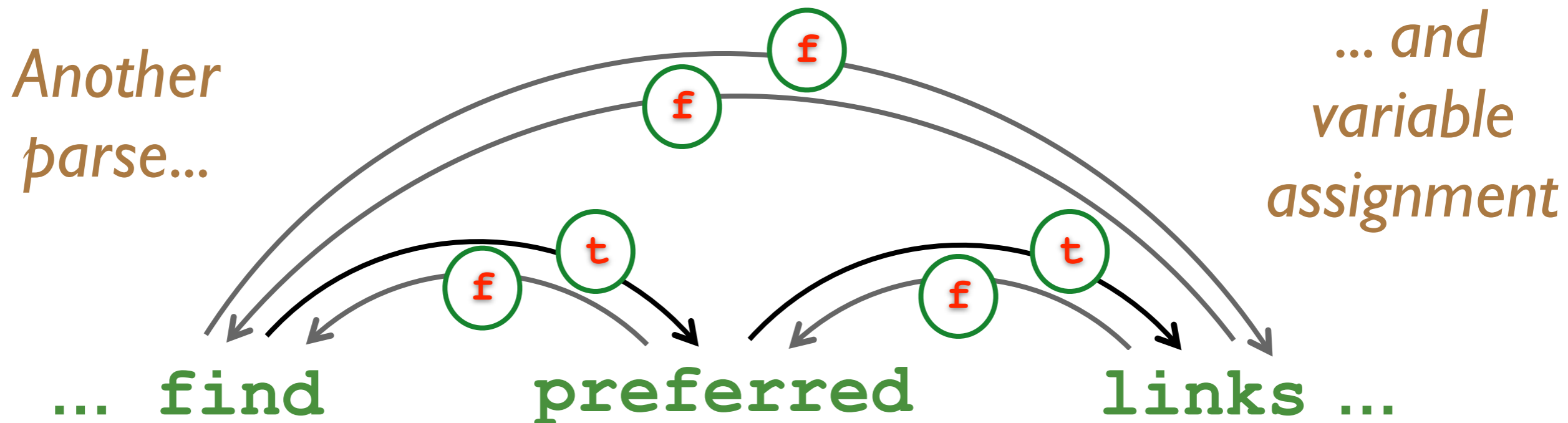

Graphical Models for Parsing

- First, a labeling example

- ❖ CRF for POS tagging

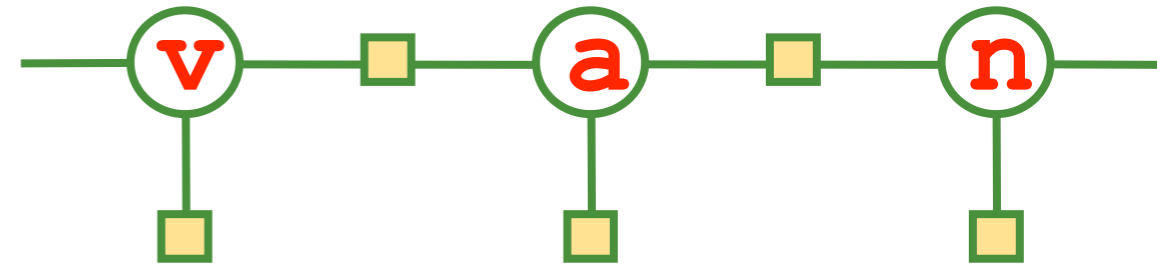

- Now let's do dependency parsing!

- ❖ $O(n^2)$ boolean variables for the possible links

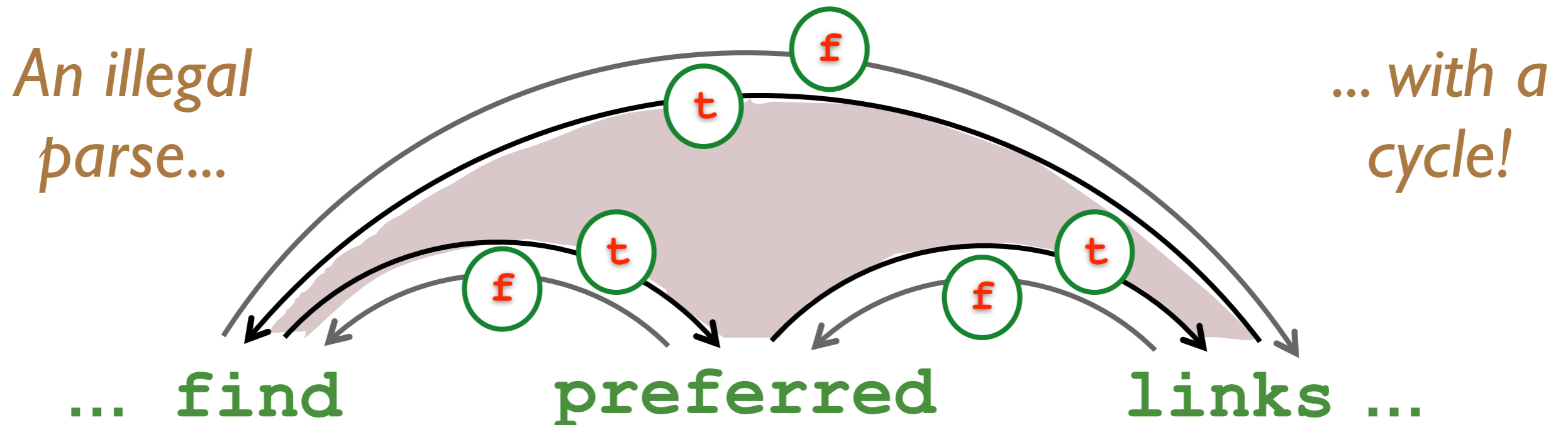

Graphical Models for Parsing

- First, a labeling example

- ❖ CRF for POS tagging

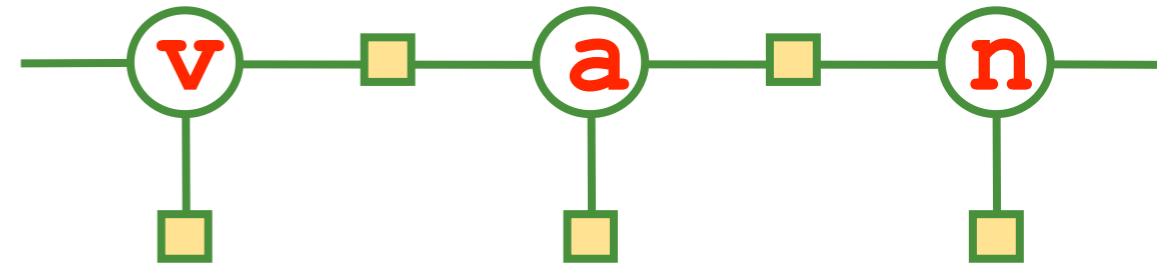

- Now let's do dependency parsing!

- ❖ $O(n^2)$ boolean variables for the possible links

An illegal parse...

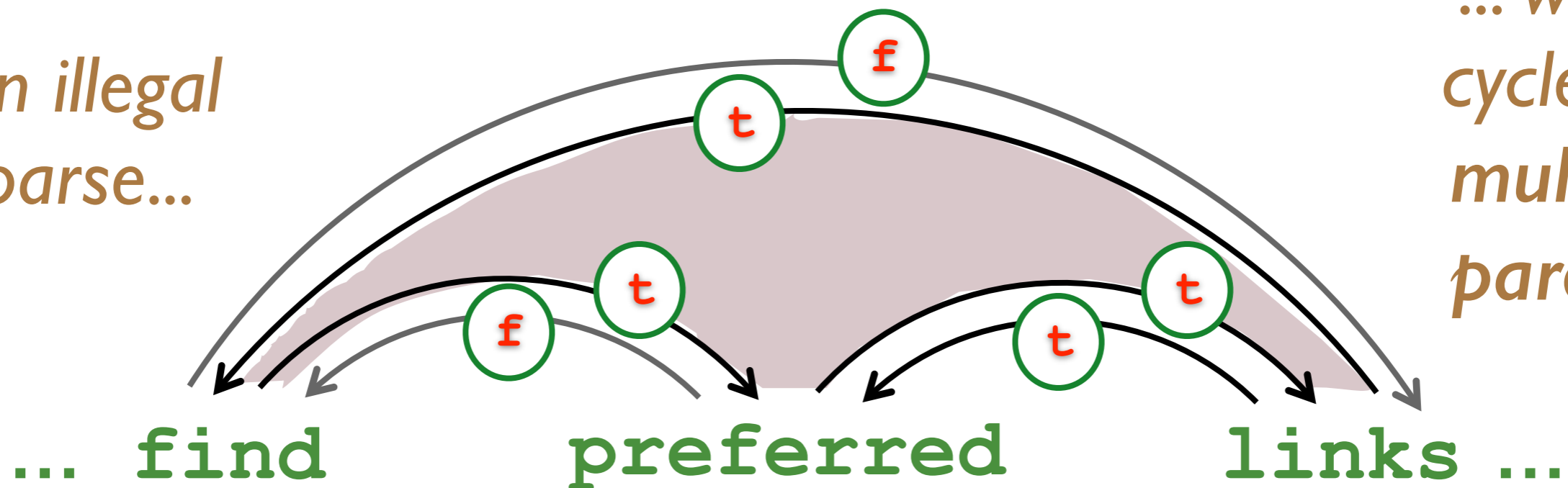

... with a cycle and multiple parents!

Local Factors for Parsing

- What factors determine parse probability?

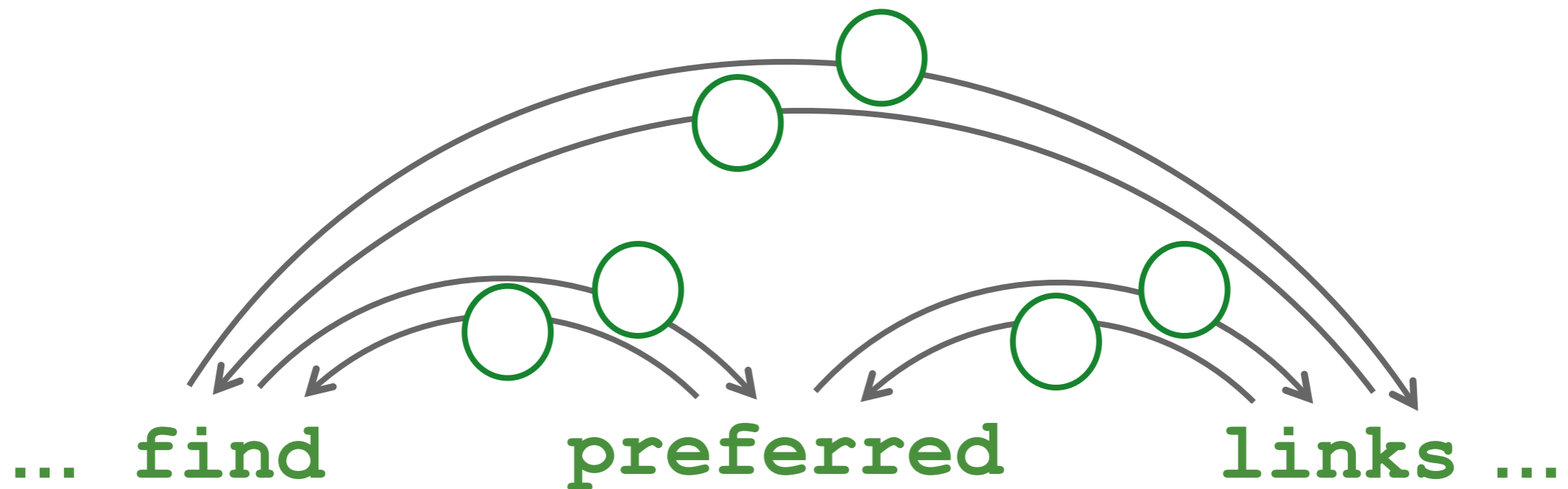

Local Factors for Parsing

- What factors determine parse probability?
 - ❖ Unary factors to score each link in isolation

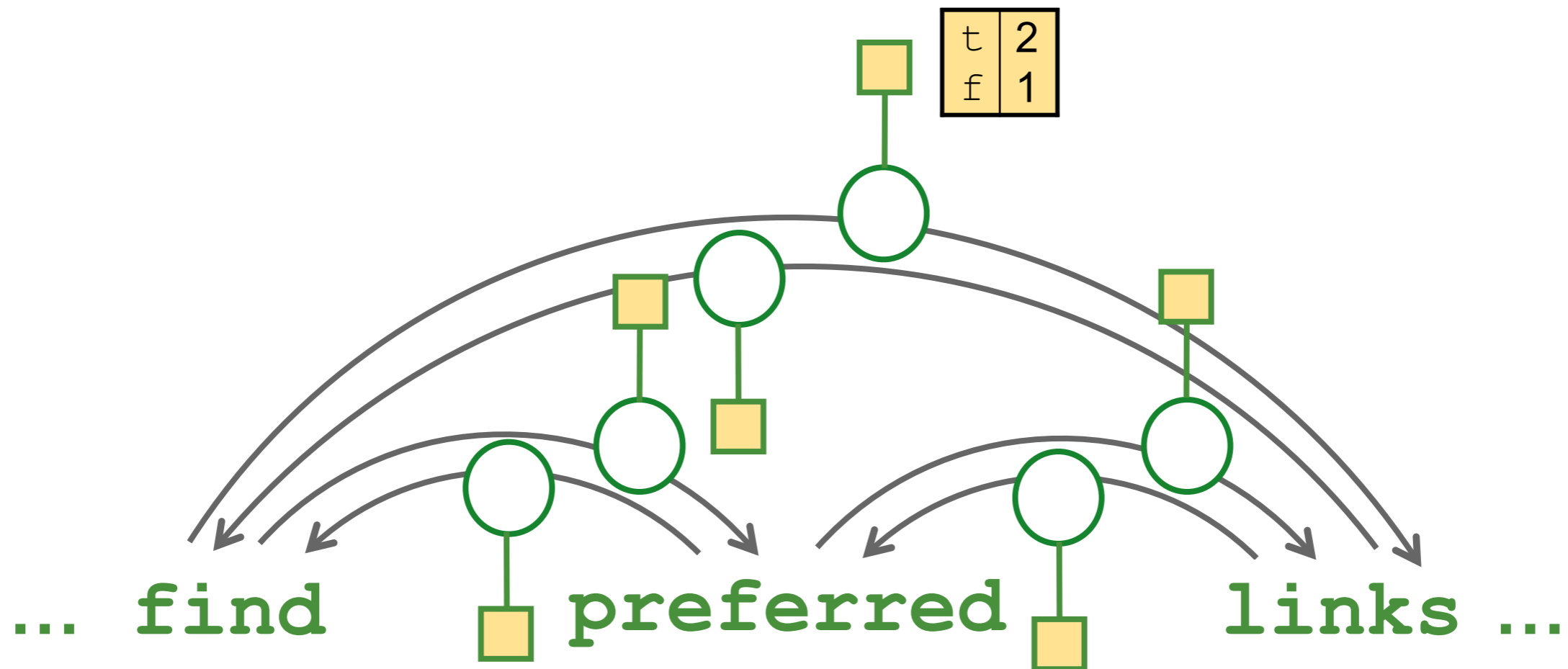

Local Factors for Parsing

- What factors determine parse probability?
 - ❖ Unary factors to score each link in isolation

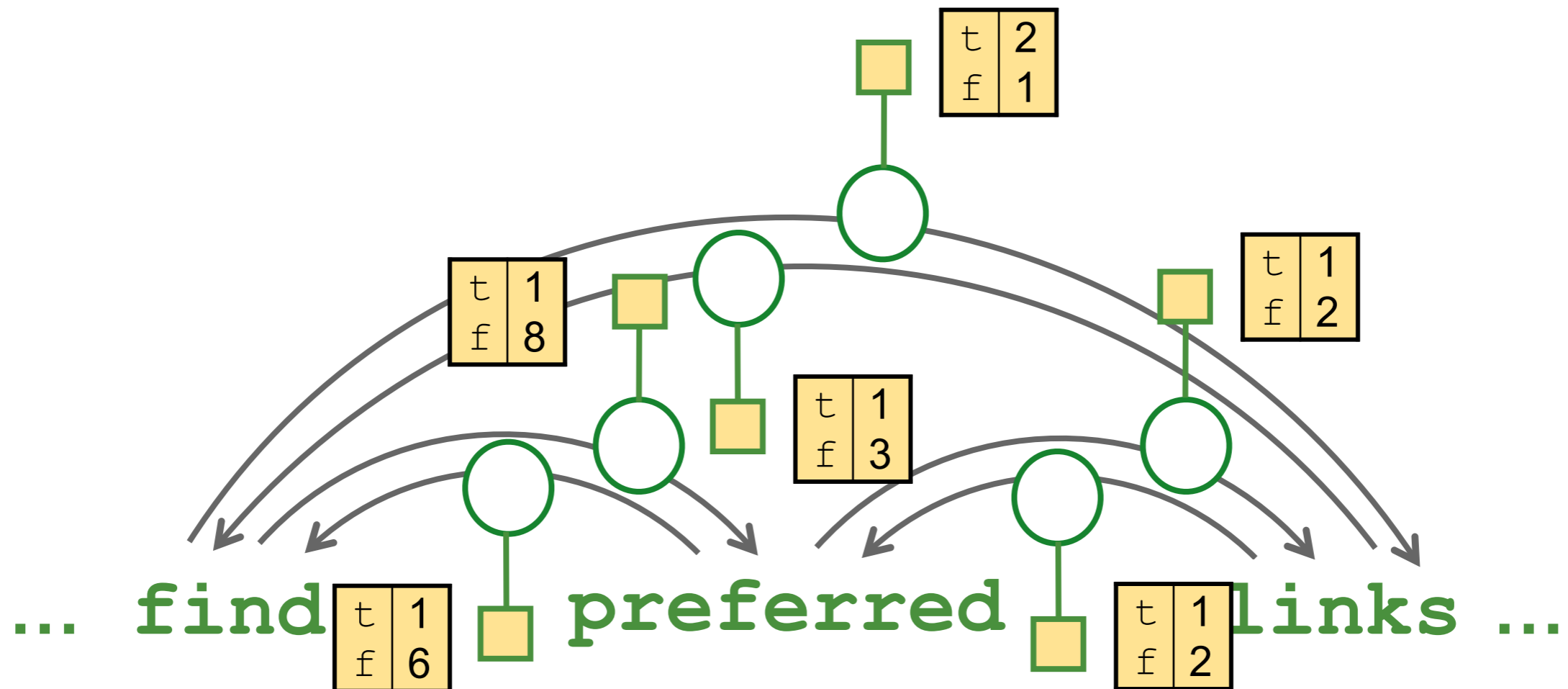

Local Factors for Parsing

- What factors determine parse probability?
 - ❖ Unary factors to score each link in isolation
- But what if the best assignment isn't a tree?

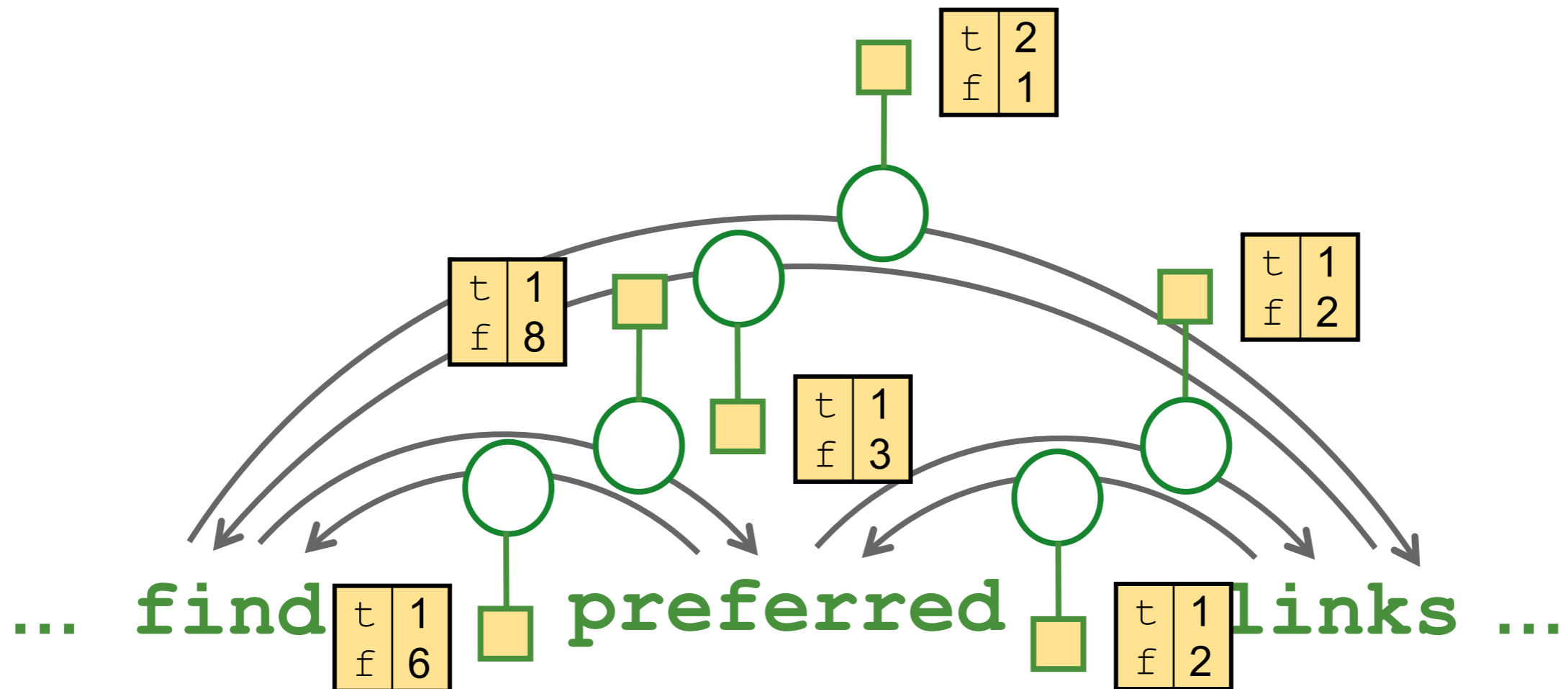

Global Factors for Parsing

- What factors determine parse probability?
 - ✦ Unary factors to score each link in isolation

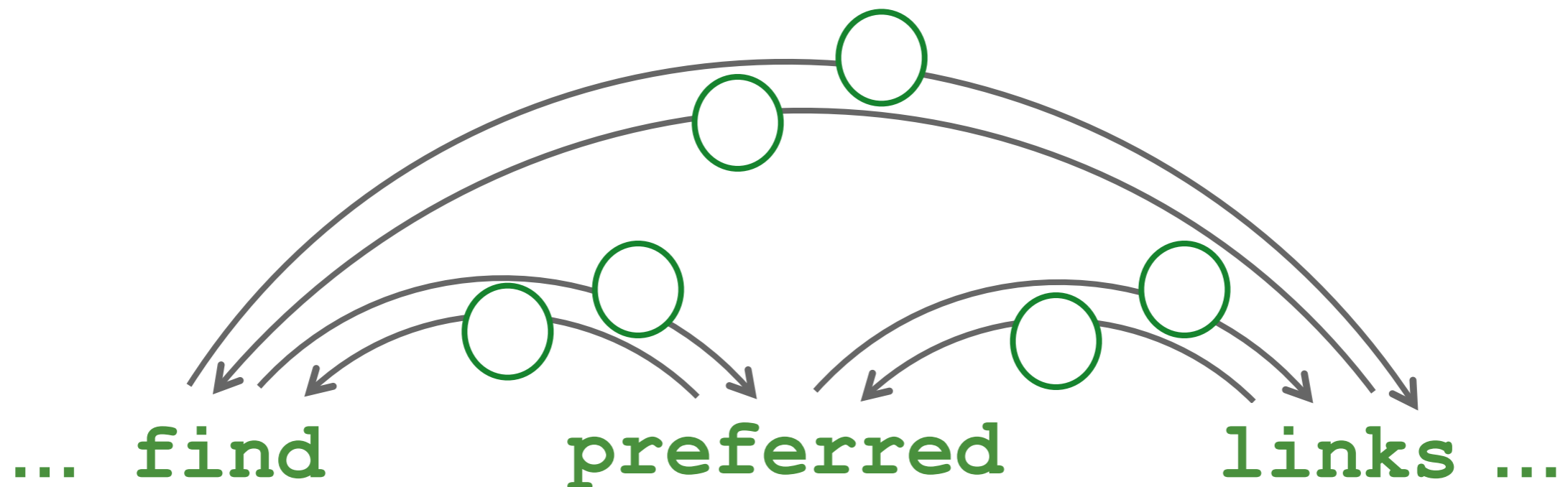

Global Factors for Parsing

- What factors determine parse probability?
 - ❖ Unary factors to score each link in isolation
 - ❖ Global TREE factor to *require* links to form a legal tree

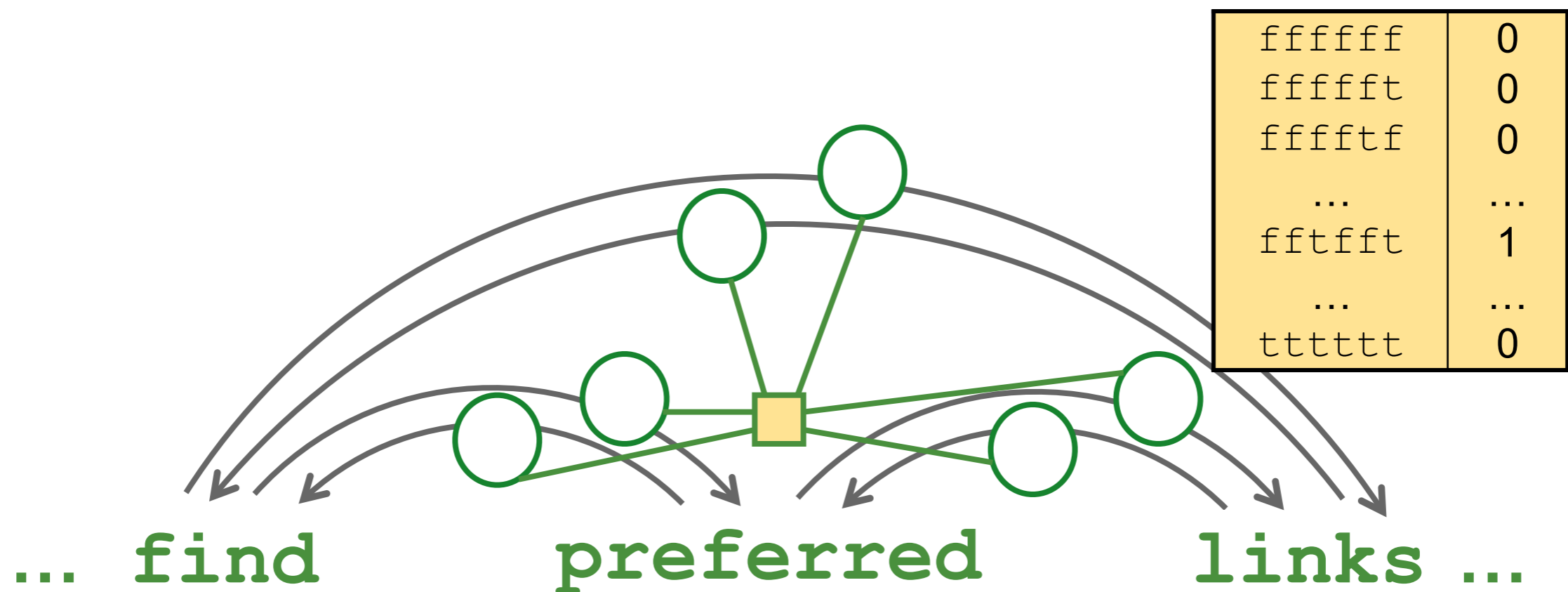

Global Factors for Parsing

- What factors determine parse probability?
 - ❖ Unary factors to score each link in isolation
 - ❖ Global TREE factor to *require* links to form a legal tree
 - A *hard constraint*: potential is either 0 or 1

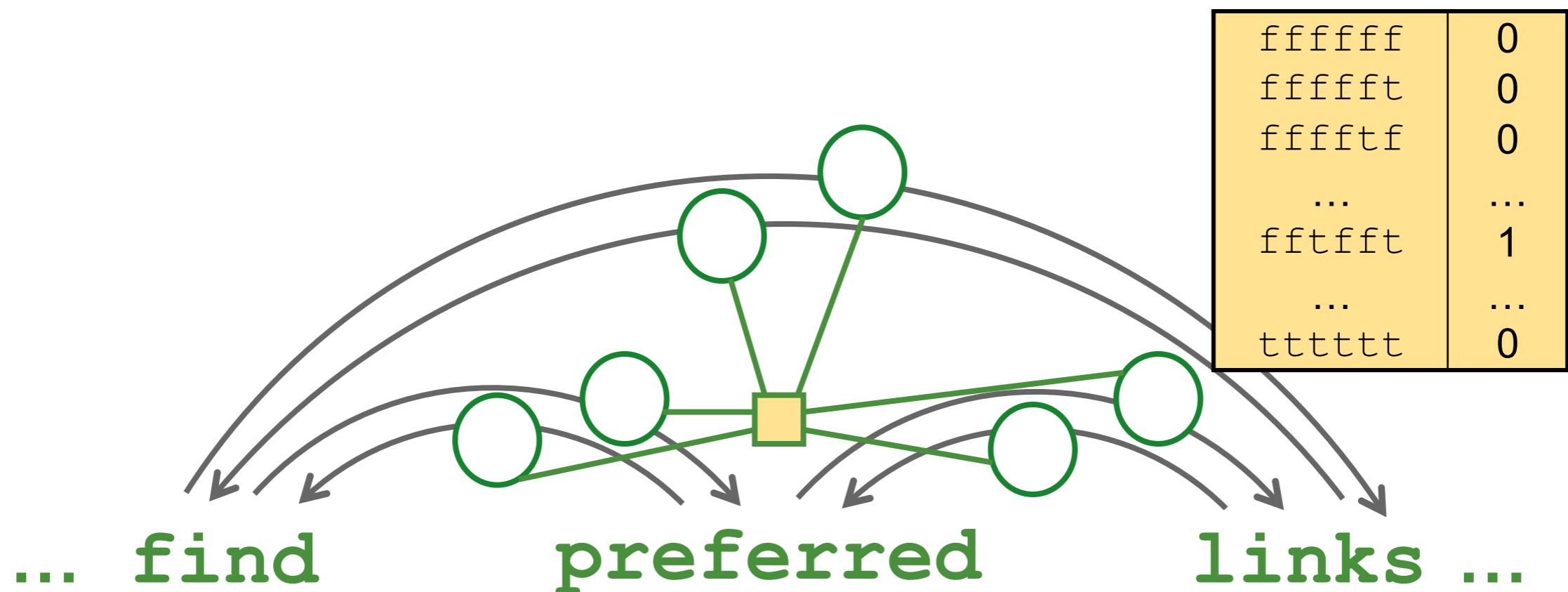

Global Factors for Parsing

- What factors determine parse probability?
 - ❖ Unary factors to score each link in isolation
 - ❖ Global TREE factor to *require* links to form a legal tree
 - A *hard constraint*: potential is either 0 or 1

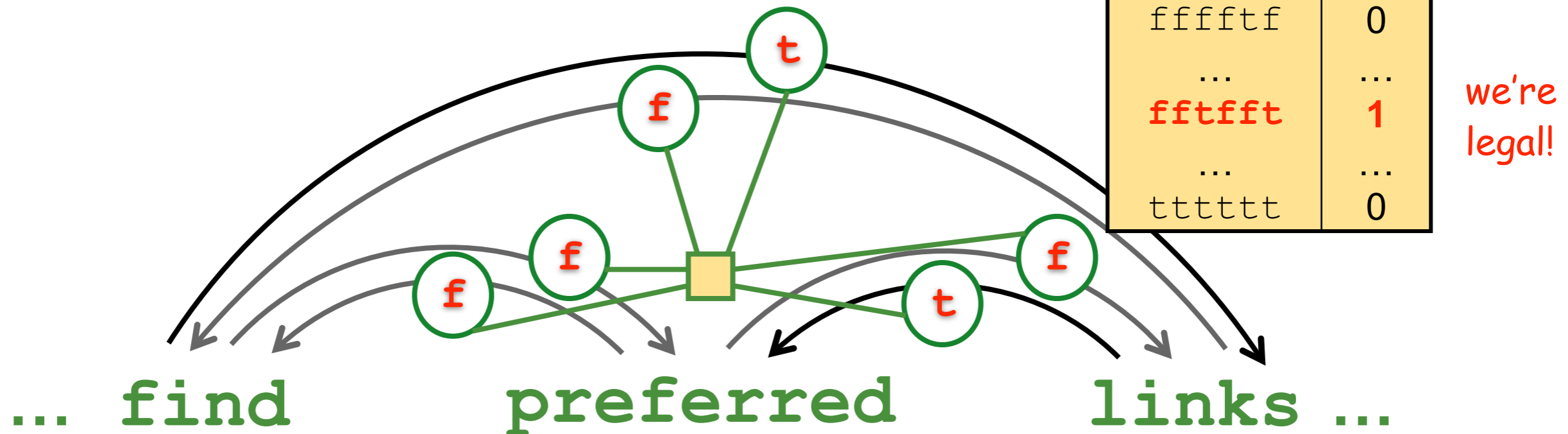

Global Factors for Parsing

- What factors determine parse tree to be projective (no crossing links)

- ❖ Unary factors to score each link in isolation
- ❖ Global TREE factor to *require* links to form a legal tree
 - A *hard constraint*: potential is either 0 or 1

So far, this is equivalent to edge-factored parsing

ffffff	0
ffffft	0
fffftf	0
...	...
fftfft	1
...	...
tttttt	0

we're legal!

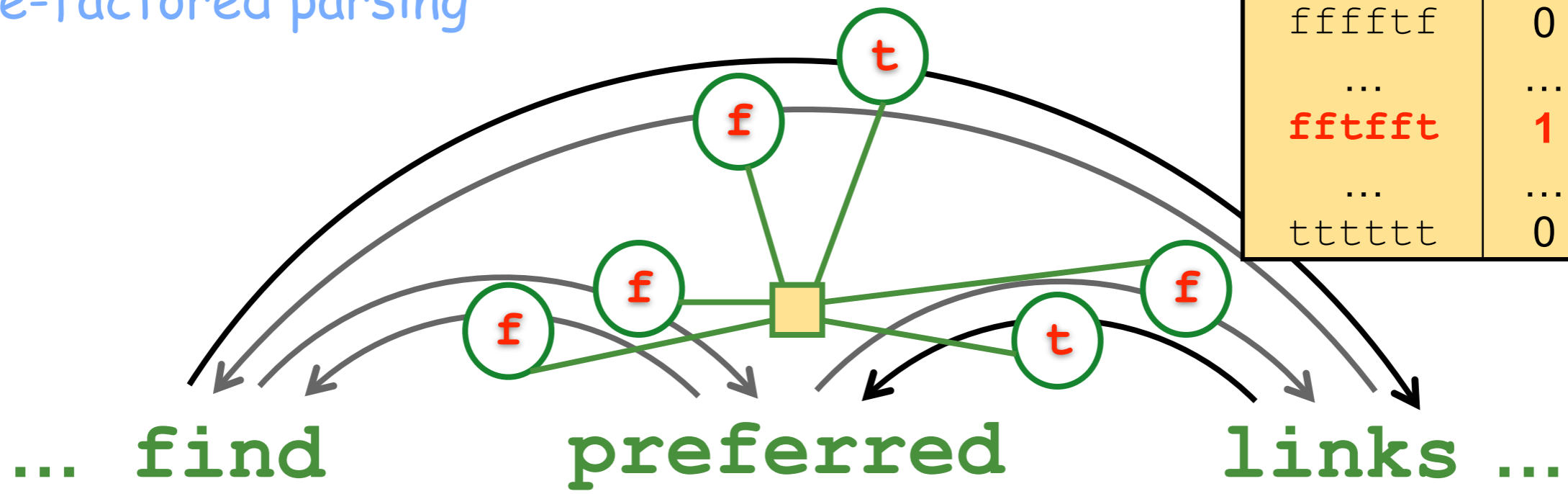

Global Factors for Parsing

- What factors determine parse tree to be projective (no crossing links)
 - ❖ Unary factors to score each link in isolation
 - ❖ Global TREE factor to *require* links to form a legal tree
 - A *hard constraint*: potential is either 0 or 1

So far, this is equivalent to edge-factored parsing

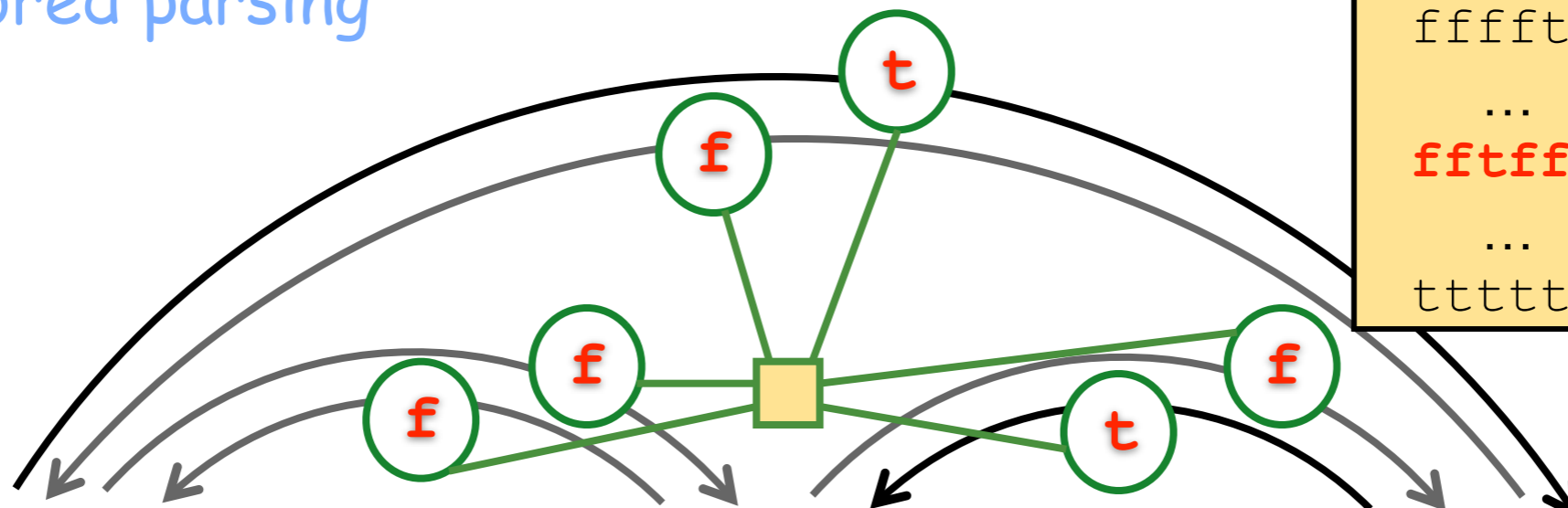

ffffff	0
ffffft	0
fffftf	0
...	...
fftfft	1
...	...
tttttt	0

we're legal!

... **fin** Note: traditional parsers don't loop through this table to consider exponentially many trees one at a time. They use combinatorial algorithms; so should we!

Local Factors for Parsing

- What factors determine parse probability?
 - ❖ Unary factors to score each link in isolation
 - ❖ Global TREE factor to *require* links to form a legal tree
 - A *hard constraint*: potential is either 0 or 1
 - ❖ Second order effects: factors on 2 variables
 - Grandparent–parent–child chains

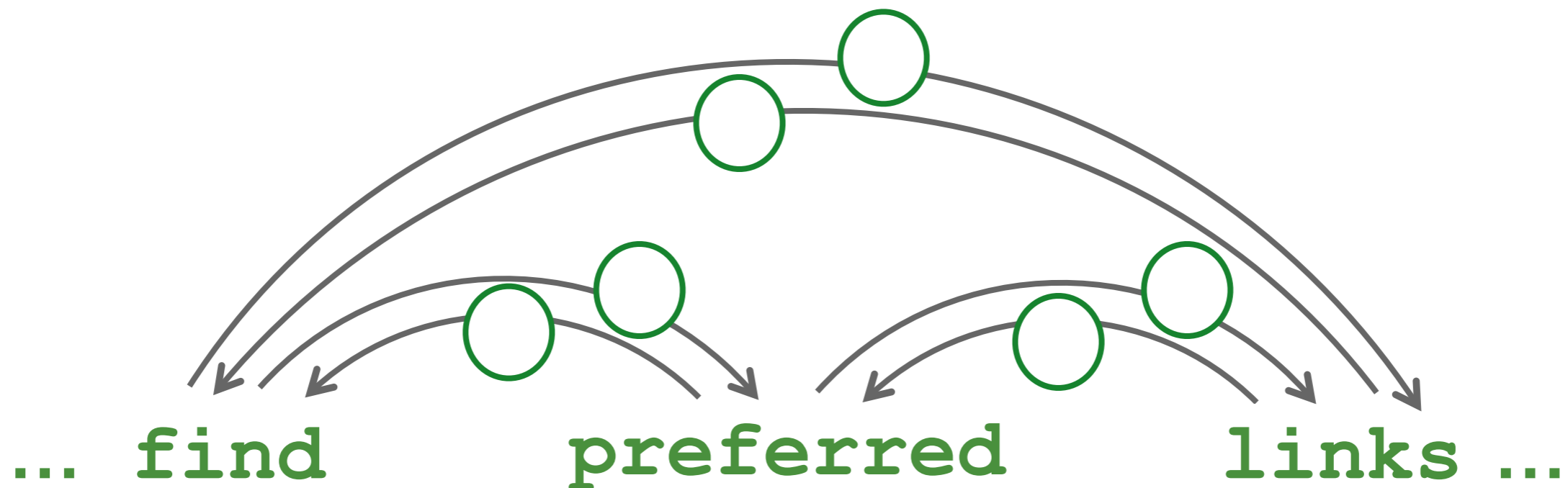

Local Factors for Parsing

- What factors determine parse probability?
 - ❖ Unary factors to score each link in isolation
 - ❖ Global TREE factor to *require* links to form a legal tree
 - A *hard constraint*: potential is either 0 or 1
 - ❖ Second order effects: factors on 2 variables
 - Grandparent–parent–child chains

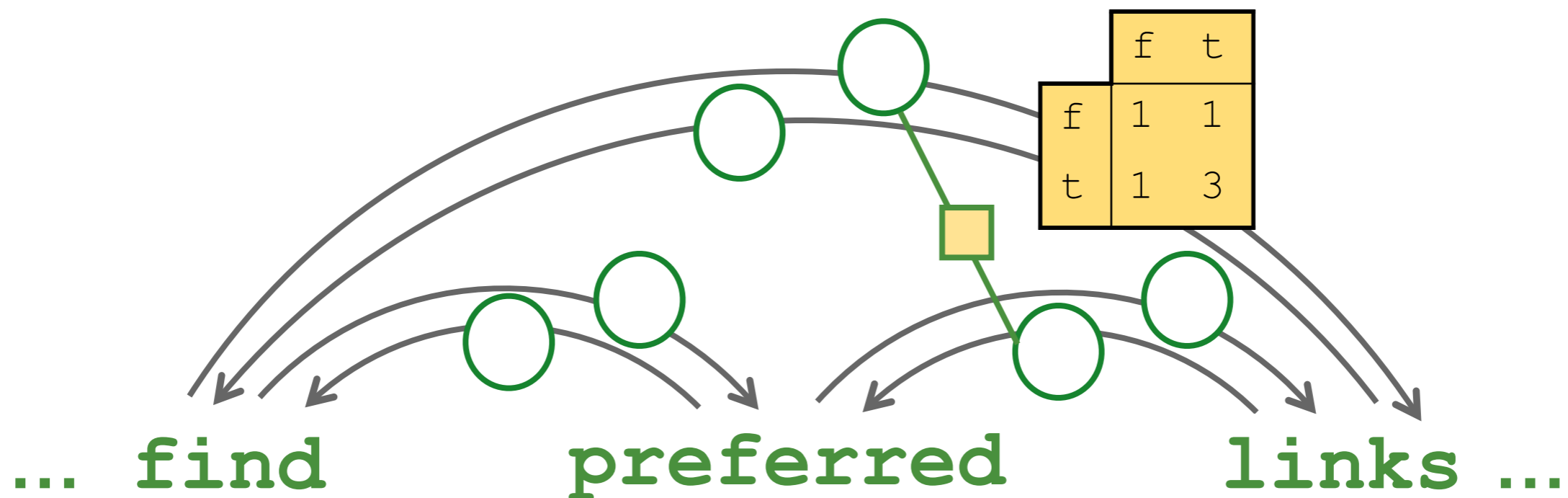

Local Factors for Parsing

- What factors determine parse probability?
 - ❖ Unary factors to score each link in isolation
 - ❖ Global TREE factor to *require* links to form a legal tree
 - A *hard constraint*: potential is either 0 or 1
 - ❖ Second order effects: factors on 2 variables
 - Grandparent–parent–child chains
 - No crossing links
 - Siblings
 - ❖ Hidden morphological tags
 - ❖ Word senses and subcategorization frames

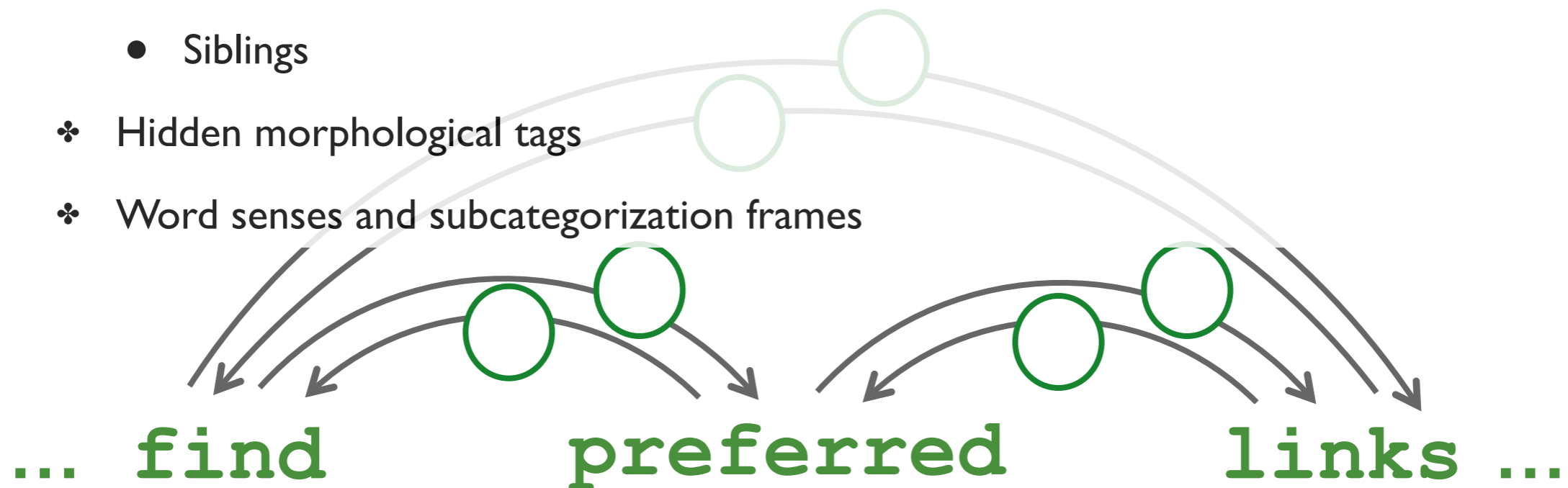

Great Ideas in ML: Message Passing



Great Ideas in ML: Message Passing

Count the soldiers



adapted from MacKay (2003) textbook

Great Ideas in ML: Message Passing

Count the soldiers

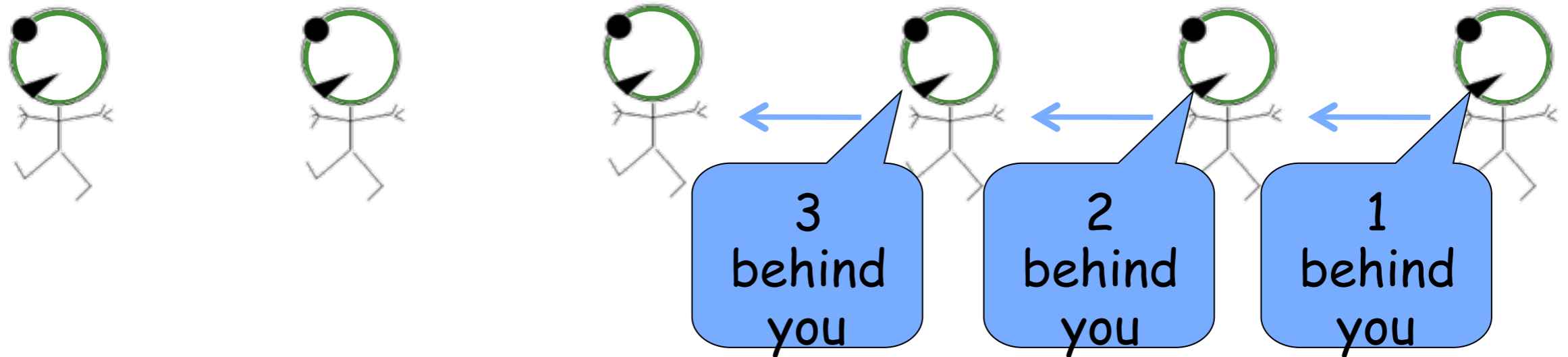

adapted from MacKay (2003) textbook

Great Ideas in ML: Message Passing

Count the soldiers

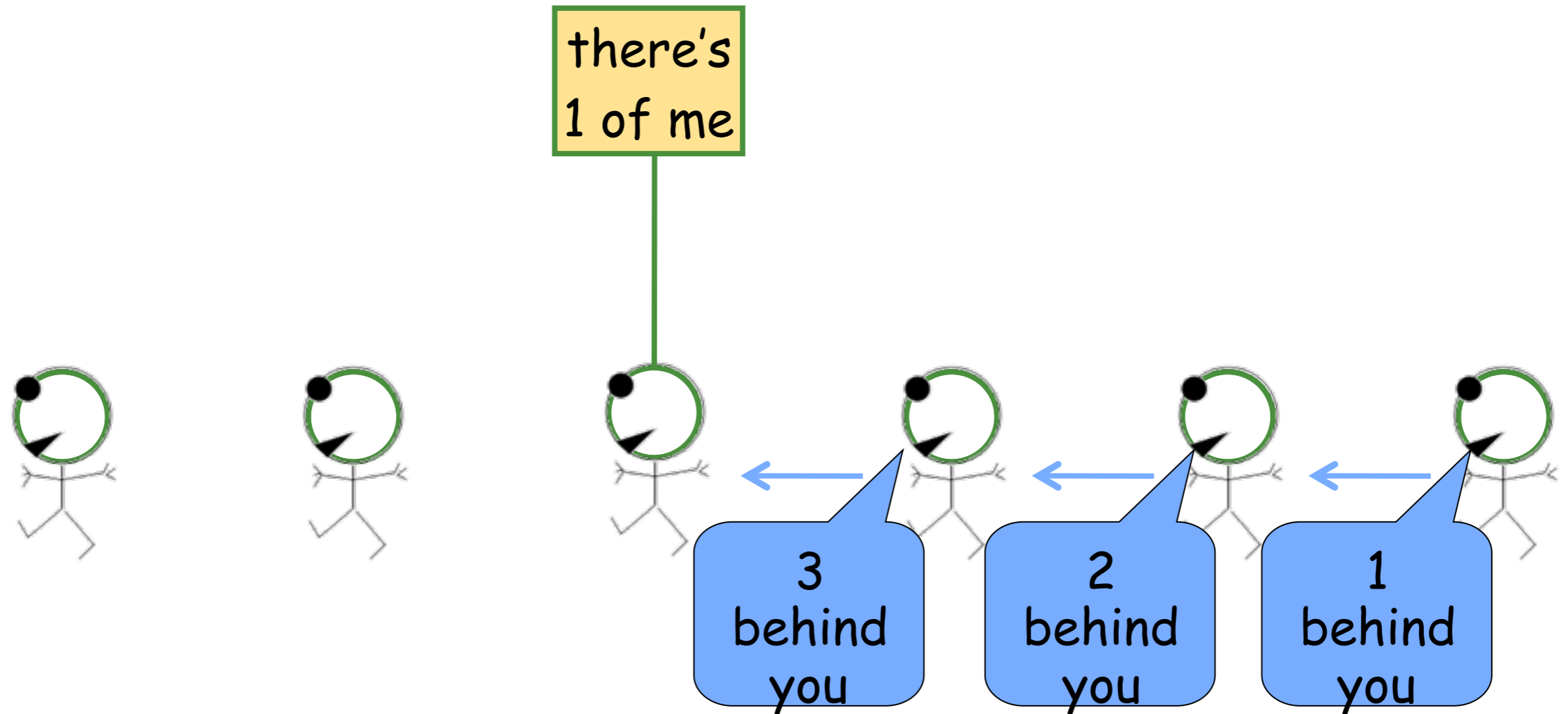

adapted from MacKay (2003) textbook

Great Ideas in ML: Message Passing

Count the soldiers

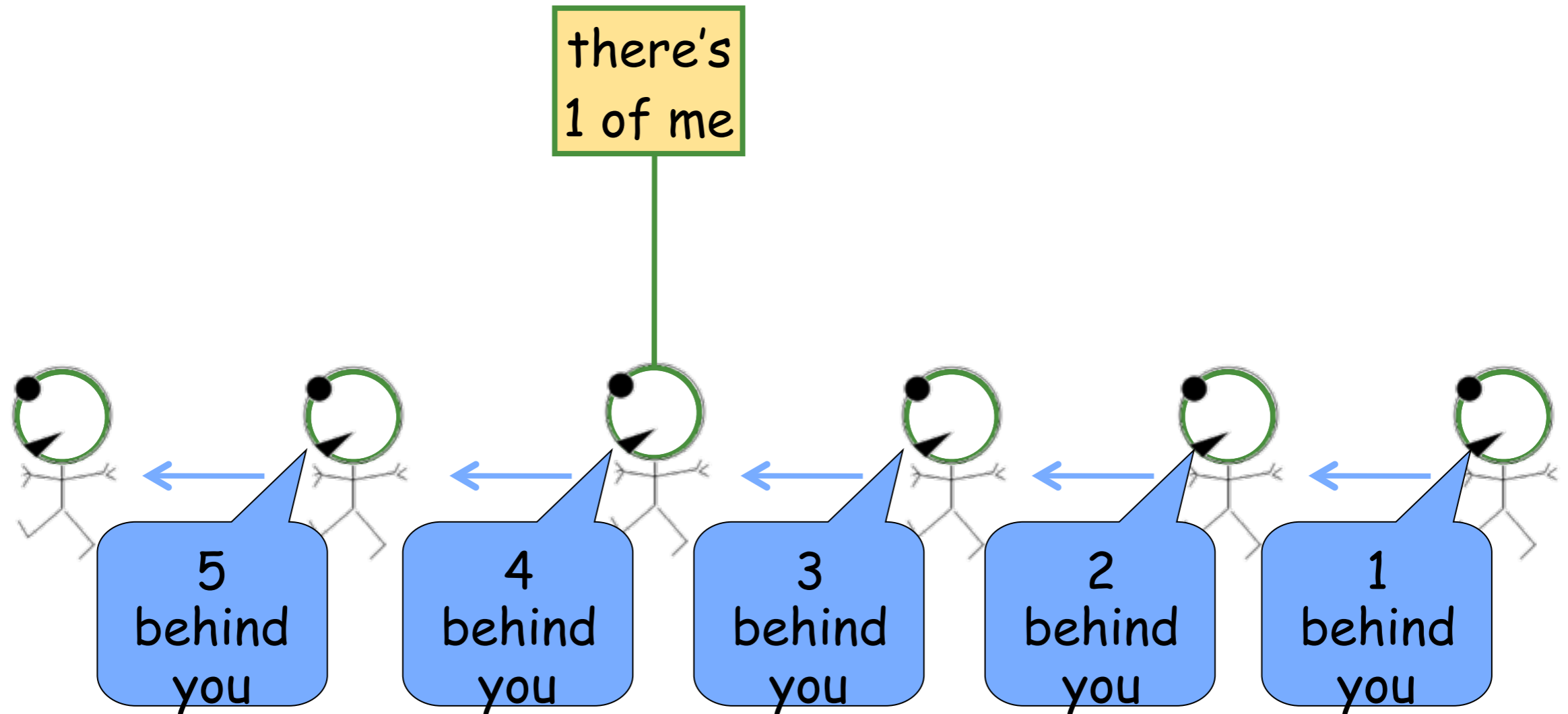

adapted from MacKay (2003) textbook

Great Ideas in ML: Message Passing

Count the soldiers

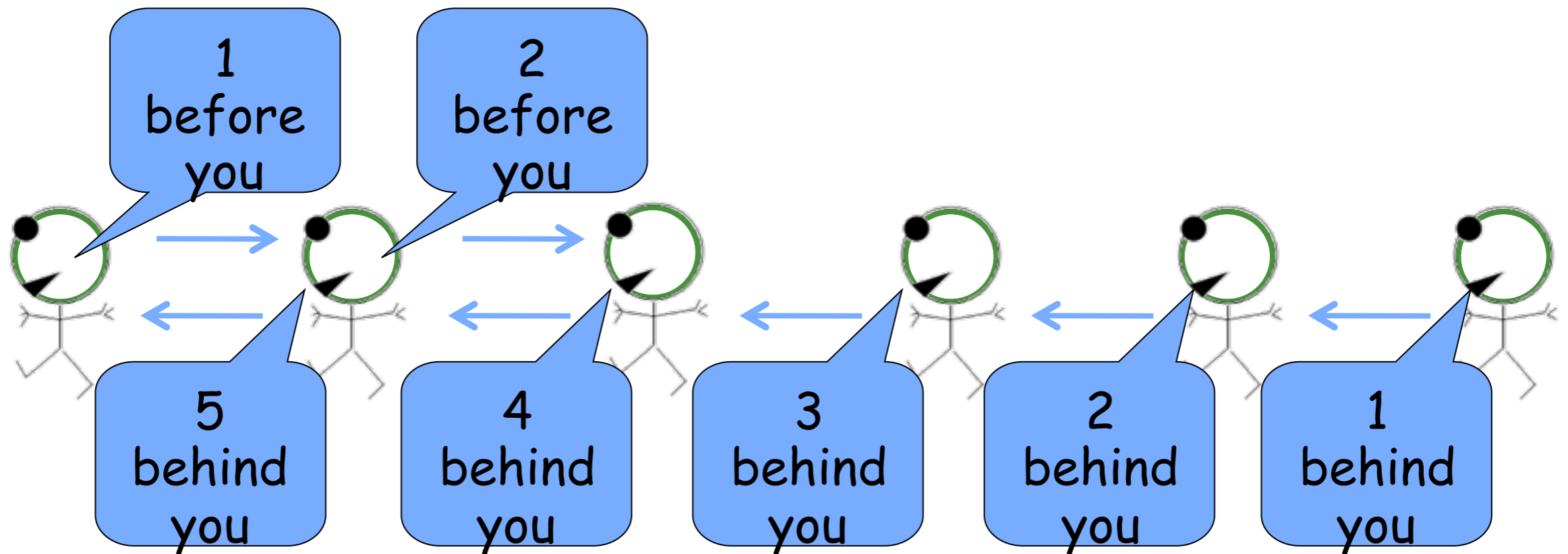

adapted from MacKay (2003) textbook

Great Ideas in ML: Message Passing

Count the soldiers

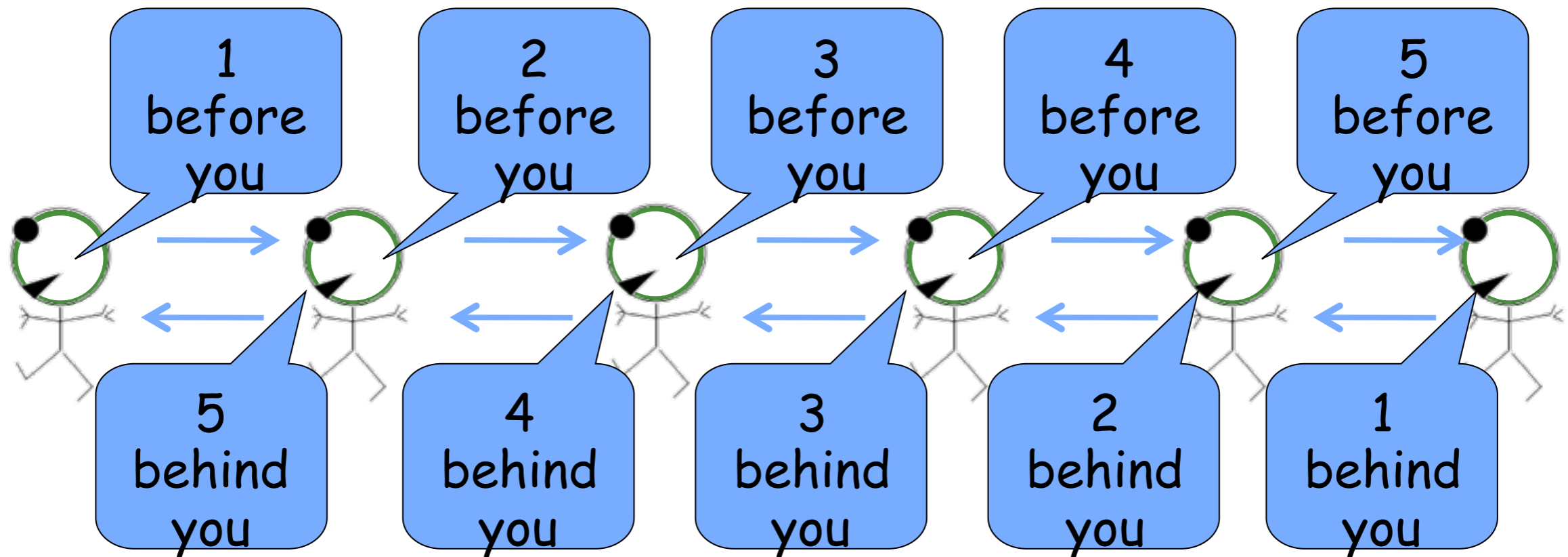

adapted from MacKay (2003) textbook

Great Ideas in ML: Message Passing

Count the soldiers

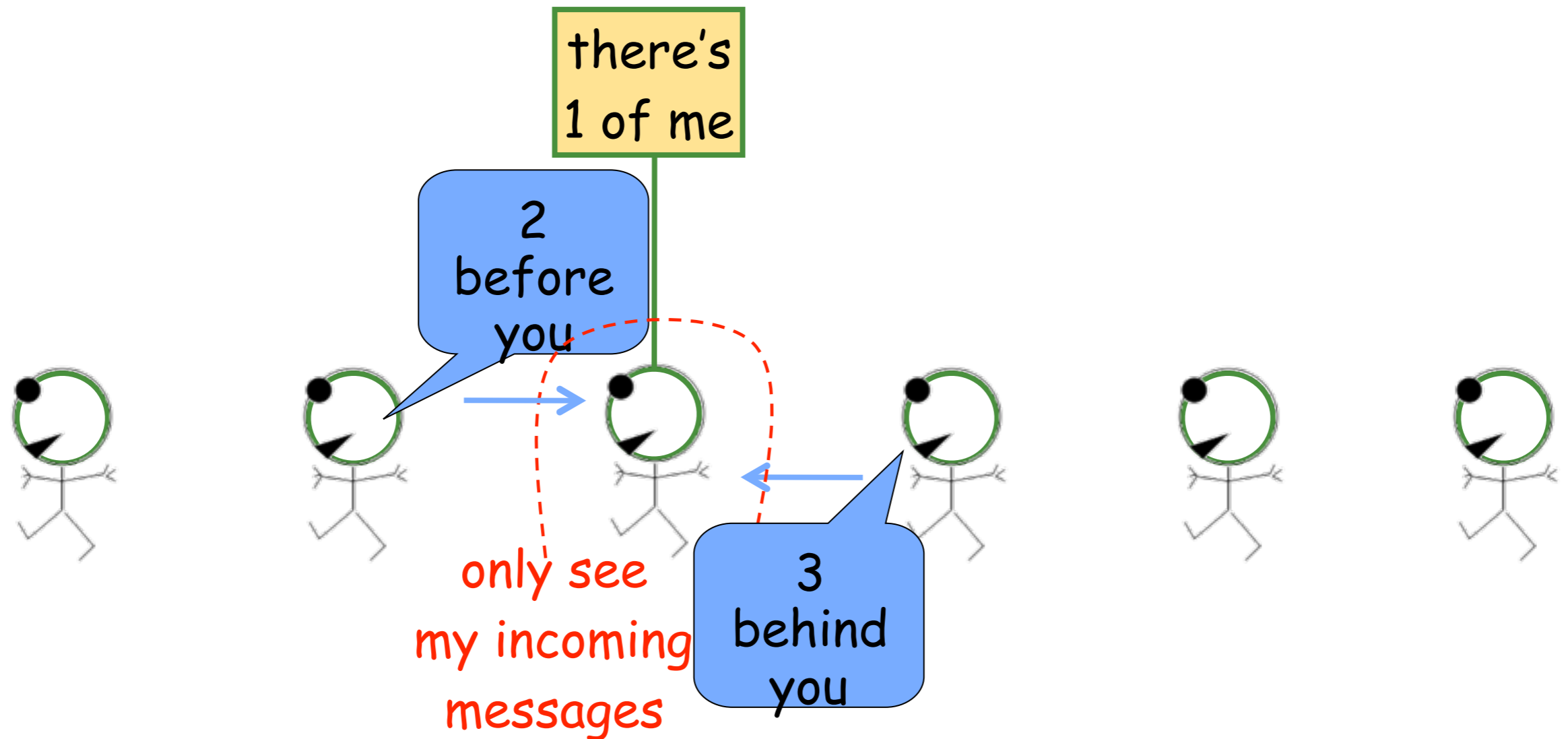

adapted from MacKay (2003) textbook

Great Ideas in ML: Message Passing

Count the soldiers

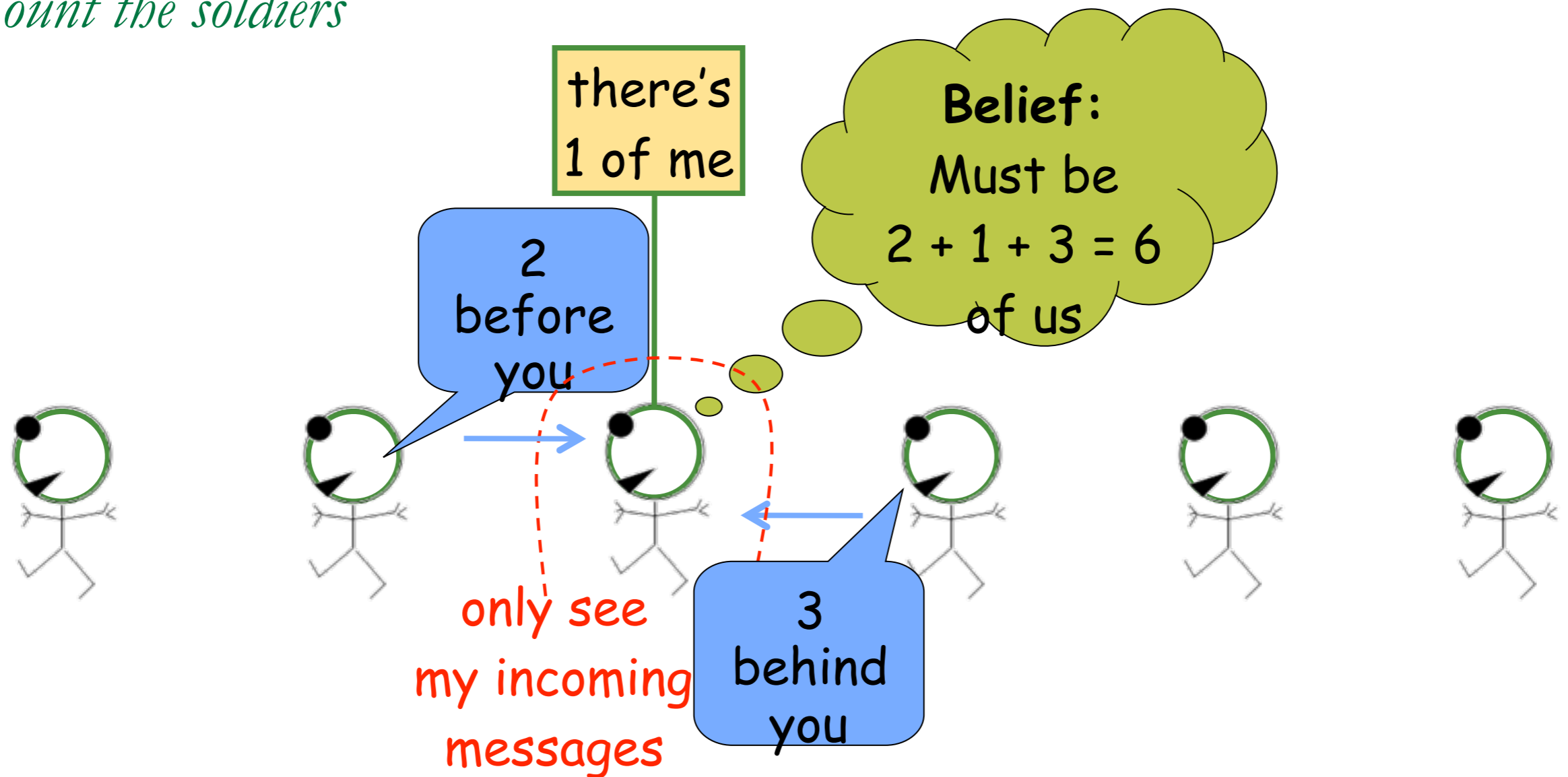

adapted from MacKay (2003) textbook

Great Ideas in ML: Message Passing

Count the soldiers

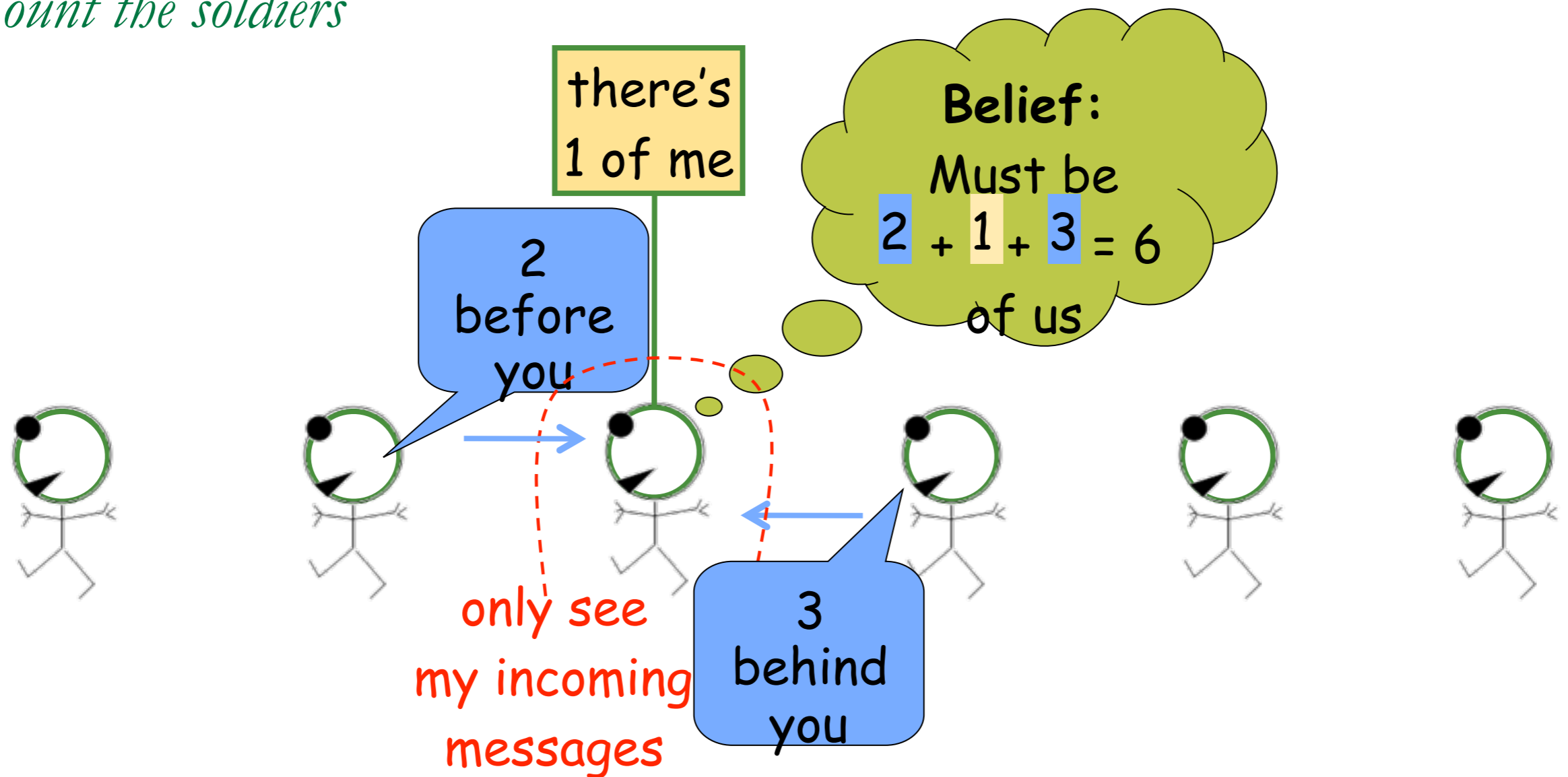

adapted from MacKay (2003) textbook

Great Ideas in ML: Message Passing

Count the soldiers

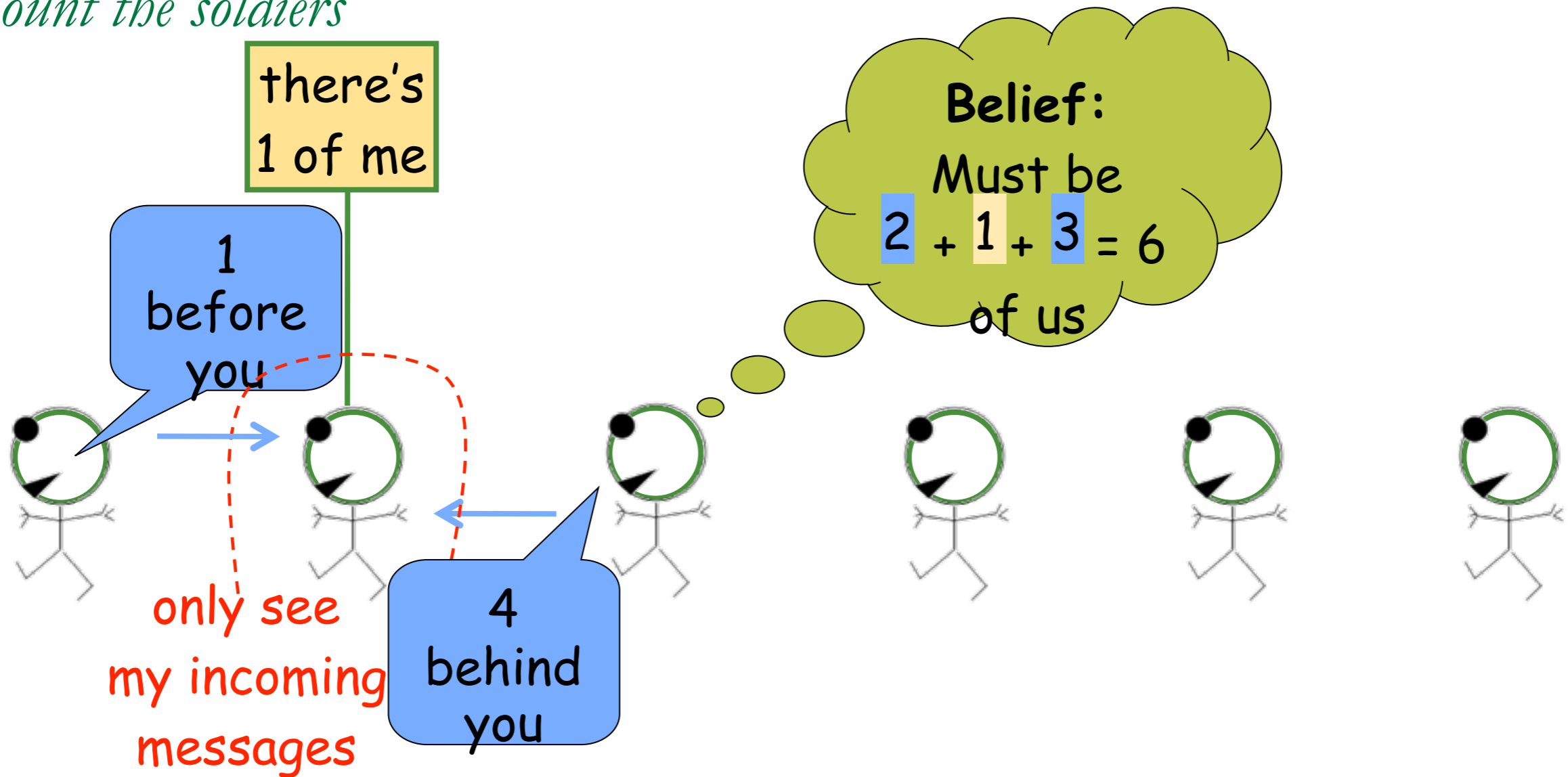

adapted from MacKay (2003) textbook

Great Ideas in ML: Message Passing

Count the soldiers

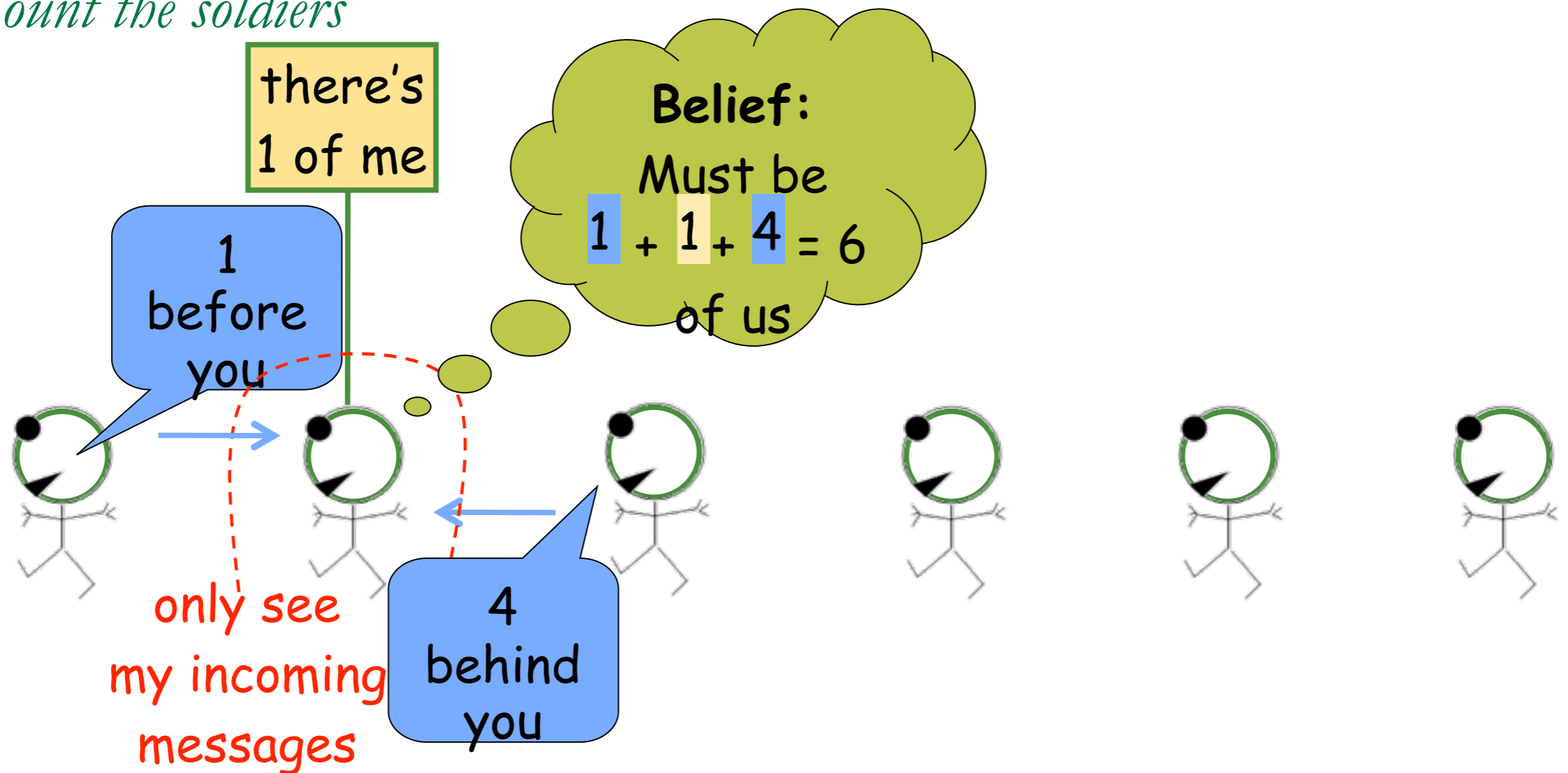

adapted from MacKay (2003) textbook

Great Ideas in ML: Message Passing

Each soldier receives reports from all branches of tree

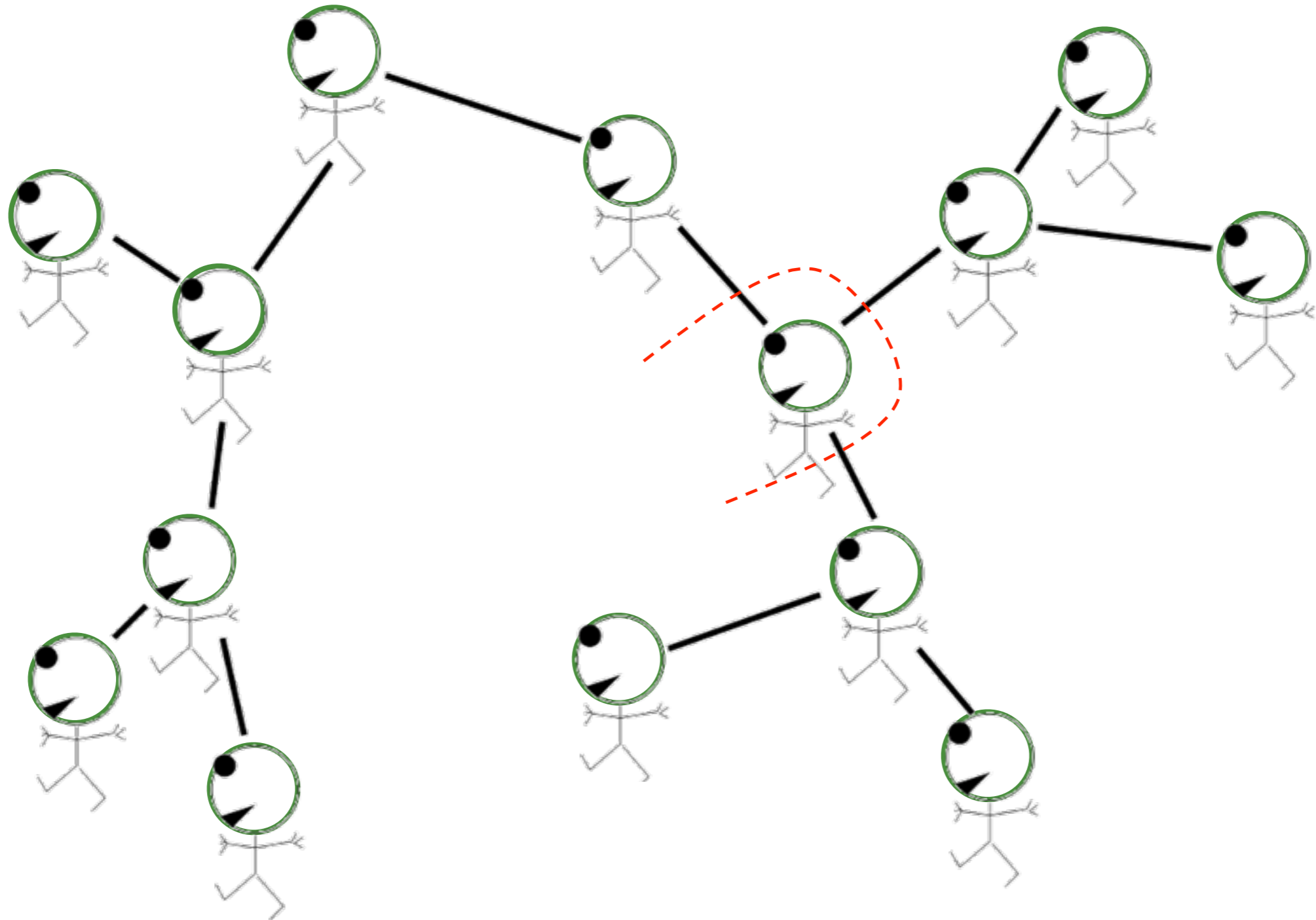

adapted from MacKay (2003) textbook

Great Ideas in ML: Message Passing

Each soldier receives reports from all branches of tree

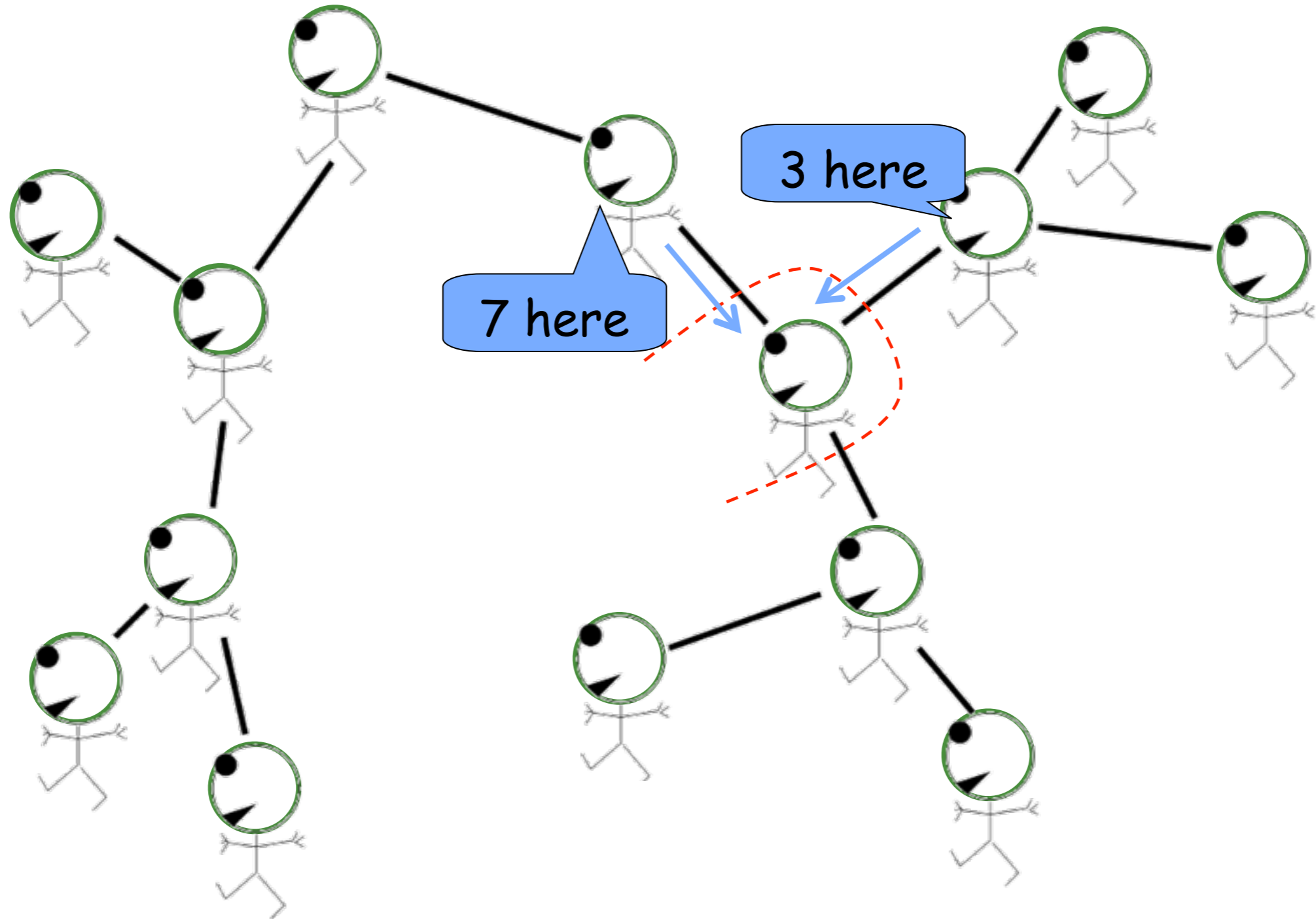

adapted from MacKay (2003) textbook

Great Ideas in ML: Message Passing

Each soldier receives reports from all branches of tree

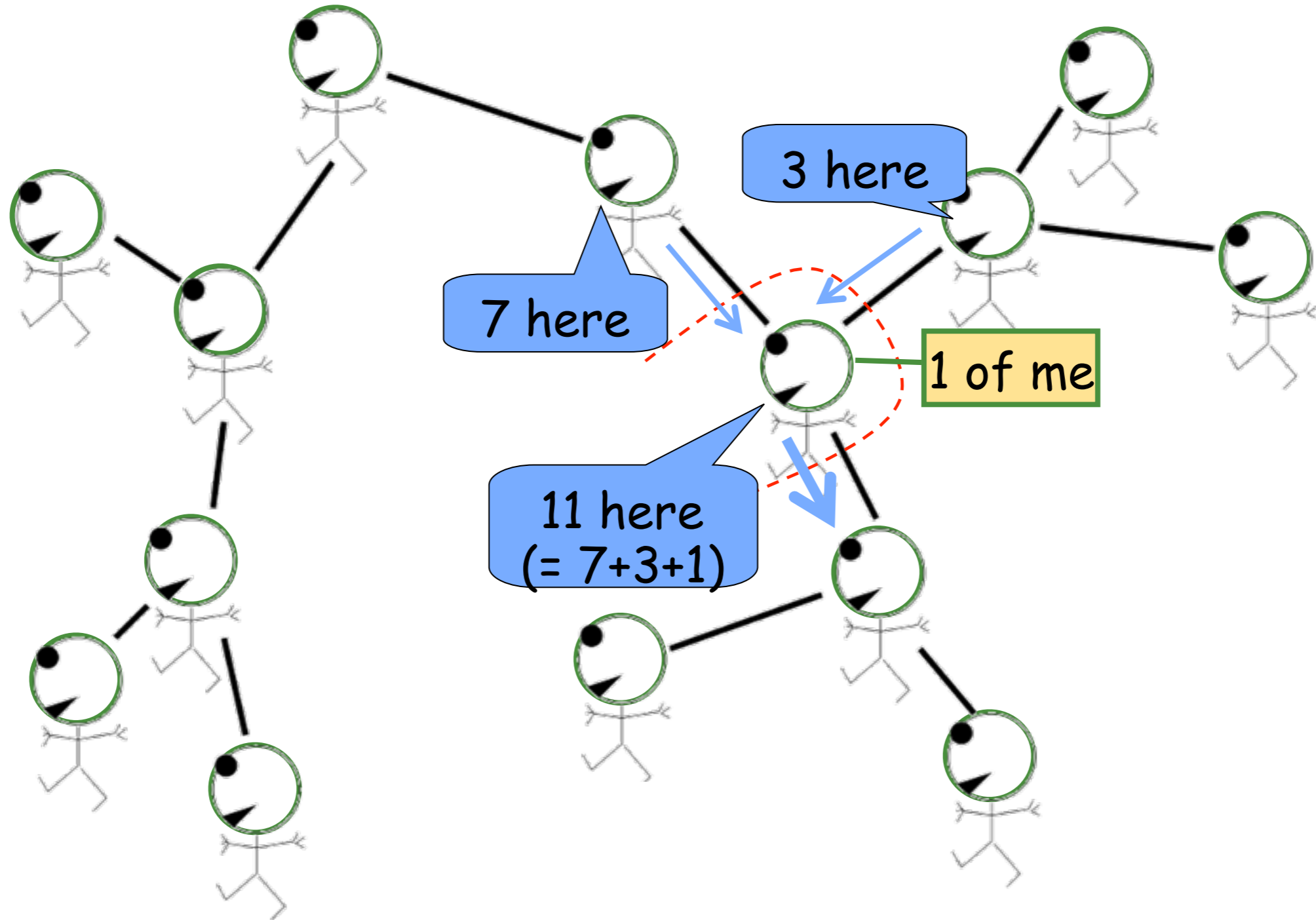

adapted from MacKay (2003) textbook

Great Ideas in ML: Message Passing

Each soldier receives reports from all branches of tree

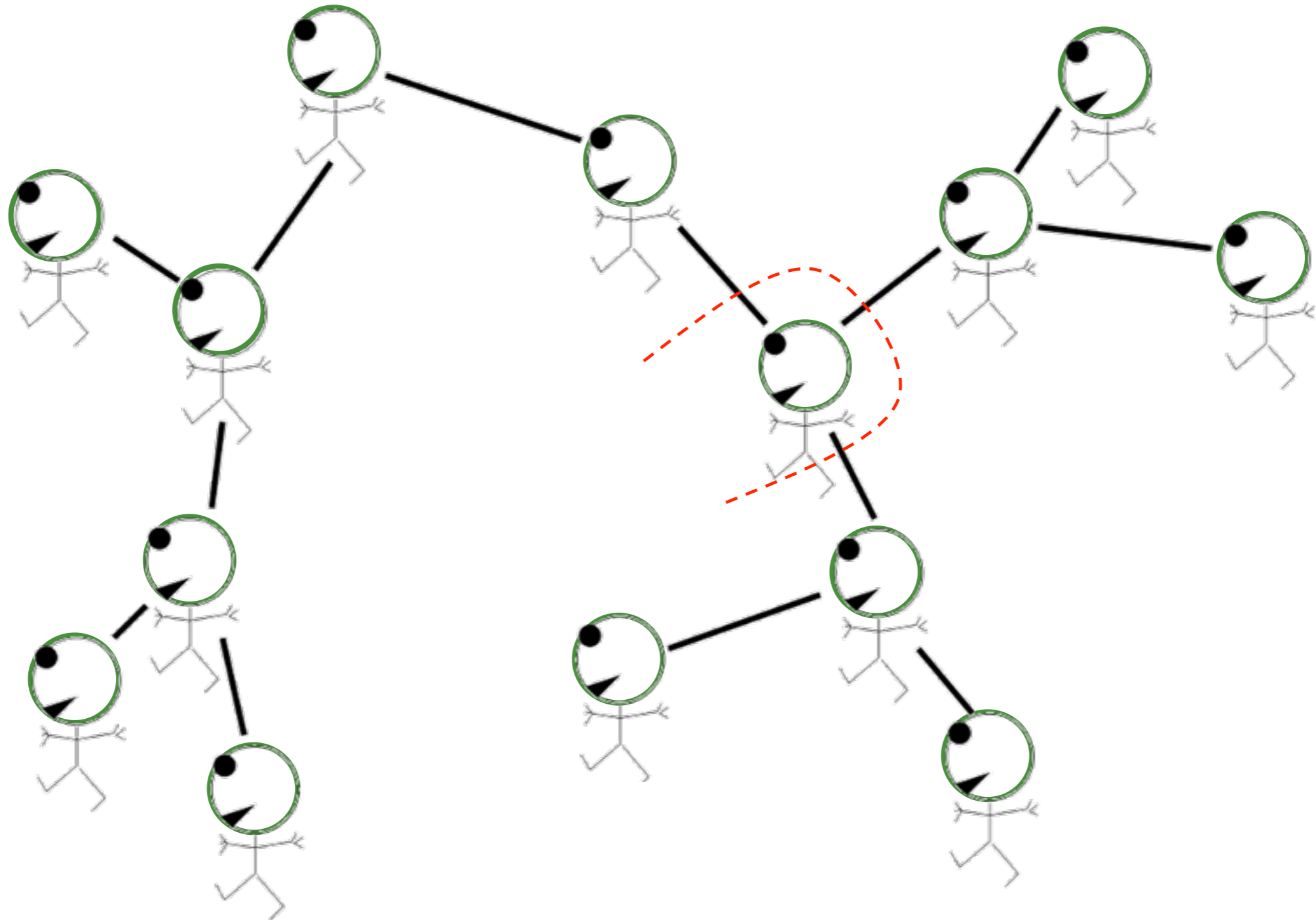

adapted from MacKay (2003) textbook

Great Ideas in ML: Message Passing

Each soldier receives reports from all branches of tree

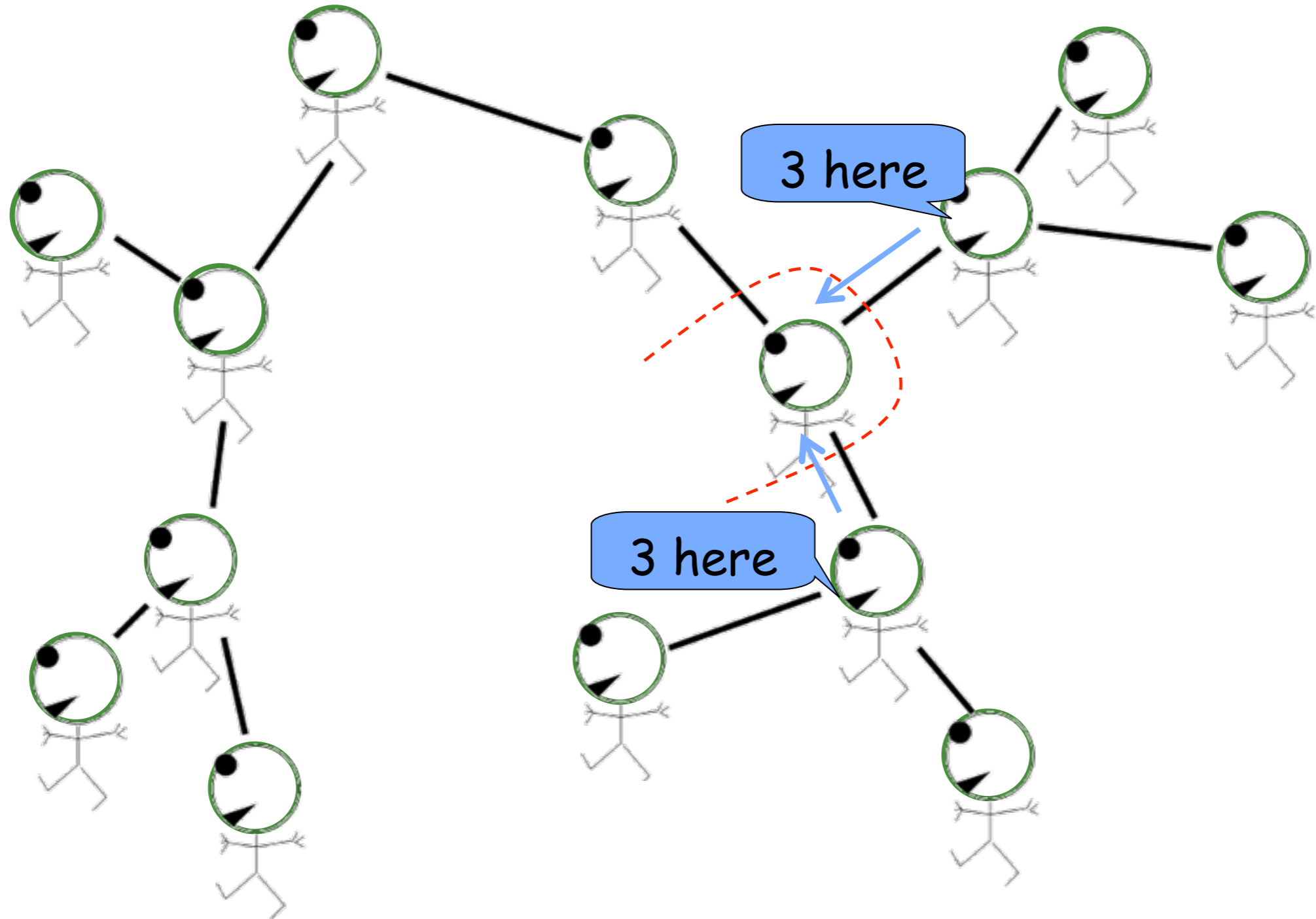

adapted from MacKay (2003) textbook

Great Ideas in ML: Message Passing

Each soldier receives reports from all branches of tree

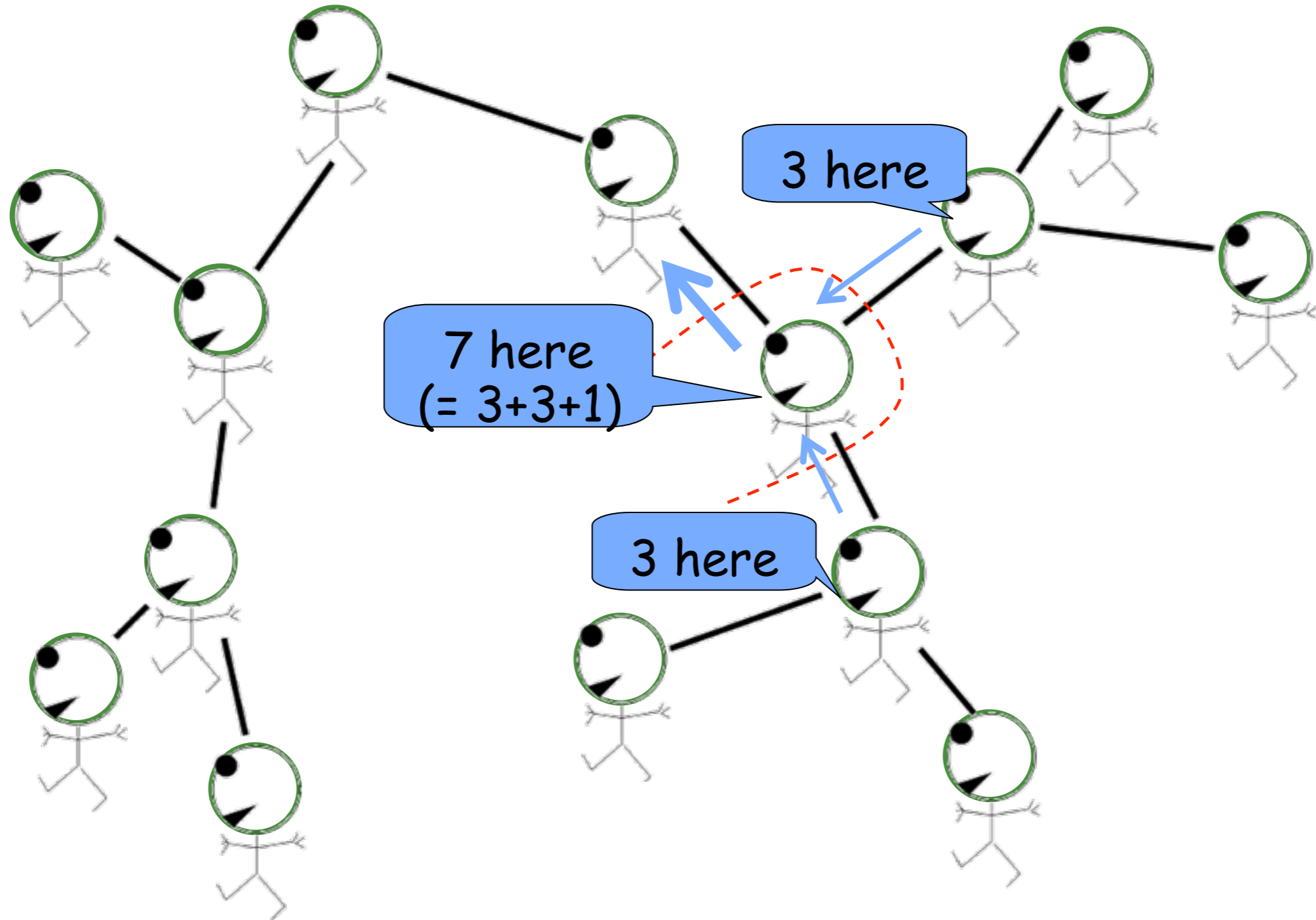

adapted from MacKay (2003) textbook

Great Ideas in ML: Message Passing

Each soldier receives reports from all branches of tree

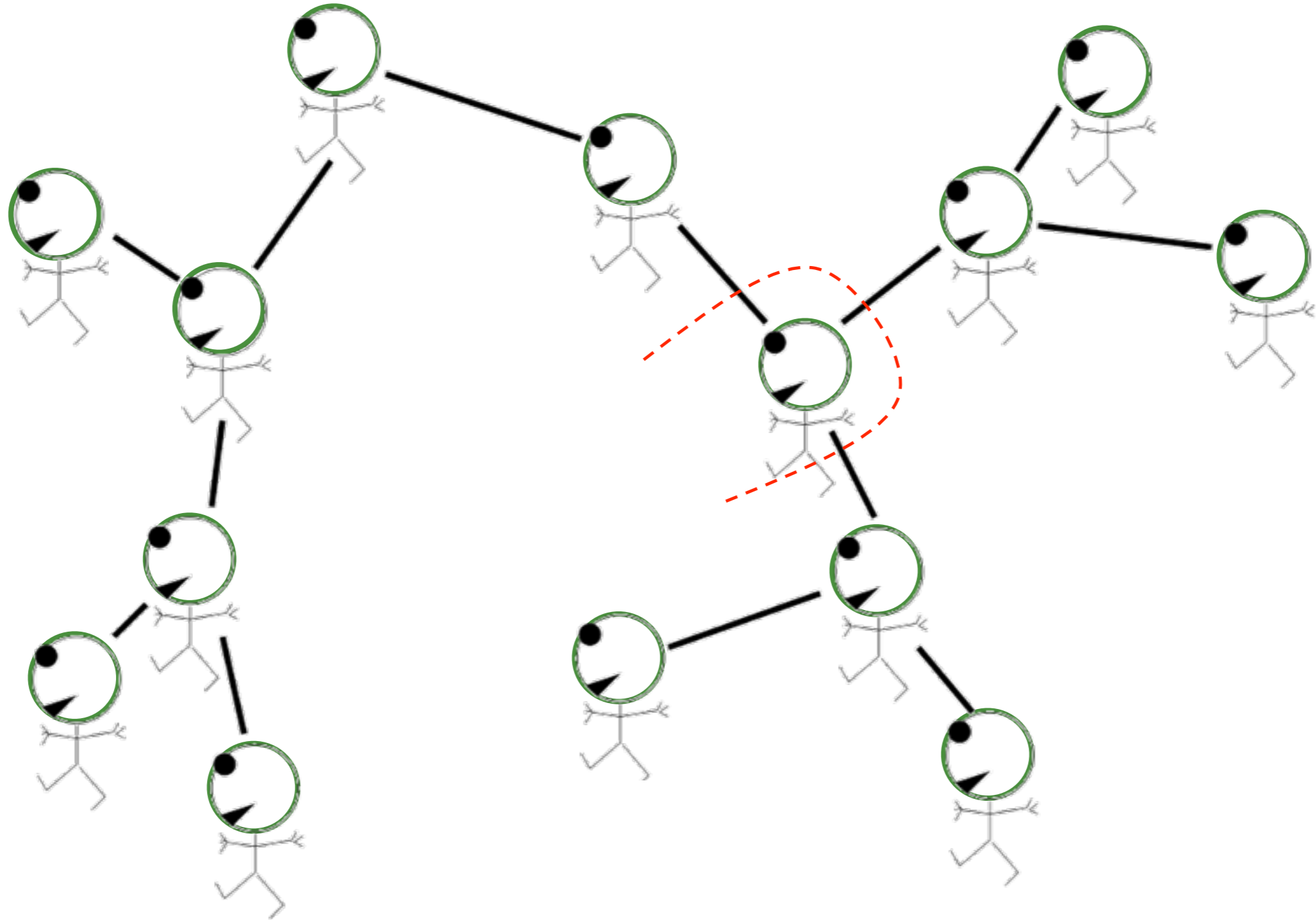

adapted from MacKay (2003) textbook

Great Ideas in ML: Message Passing

Each soldier receives reports from all branches of tree

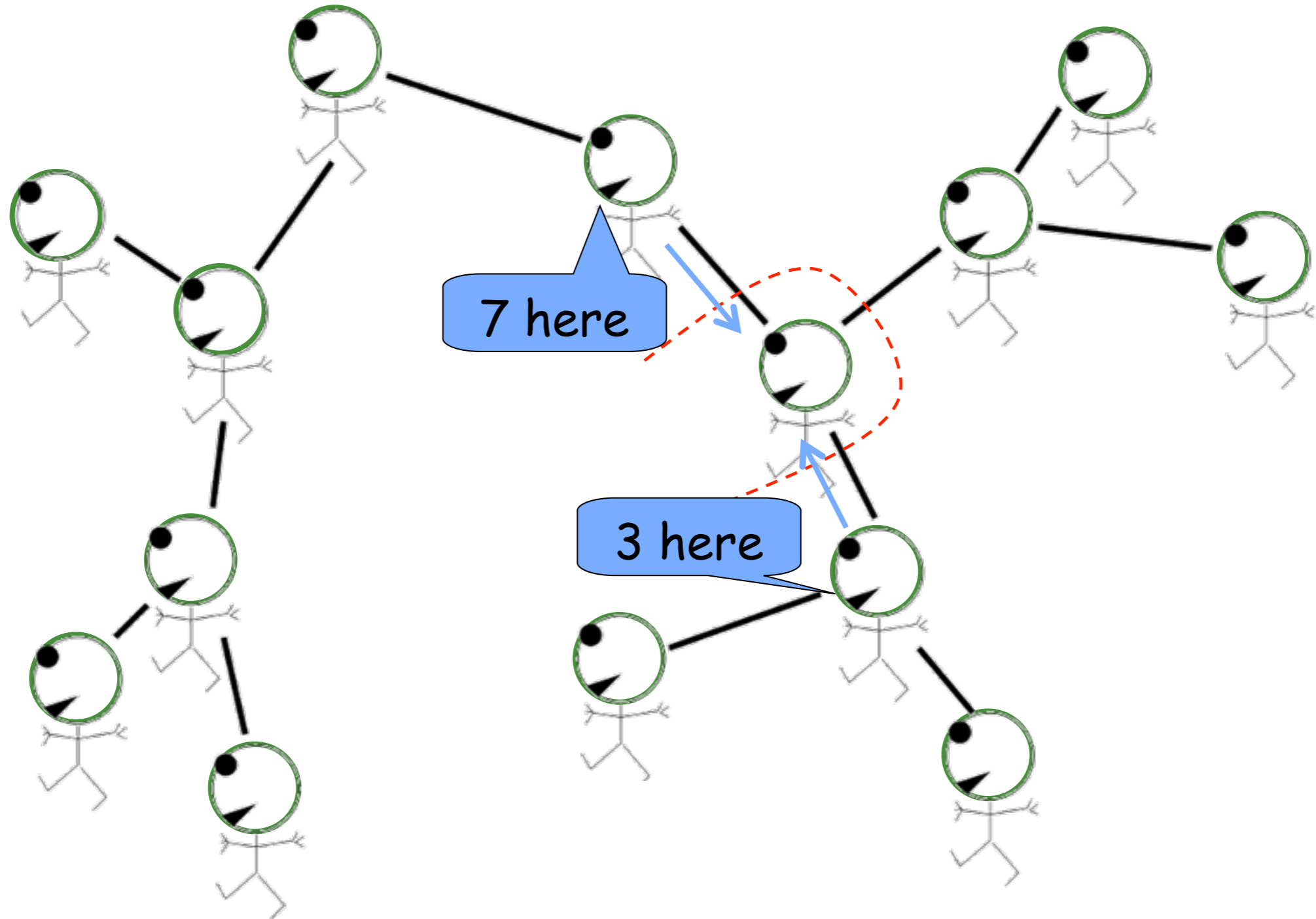

adapted from MacKay (2003) textbook

Great Ideas in ML: Message Passing

Each soldier receives reports from all branches of tree

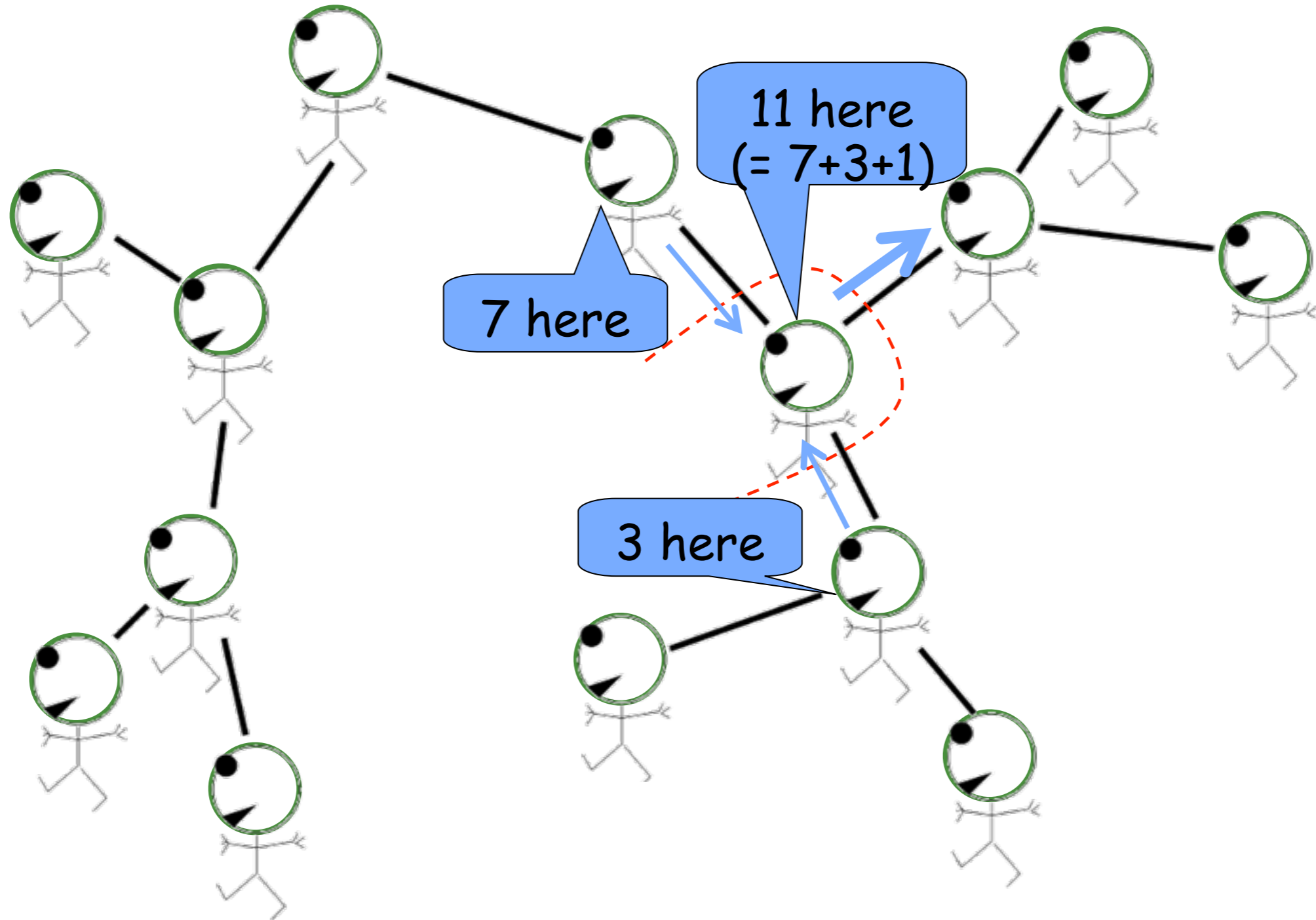

adapted from MacKay (2003) textbook

Great Ideas in ML: Message Passing

Each soldier receives reports from all branches of tree

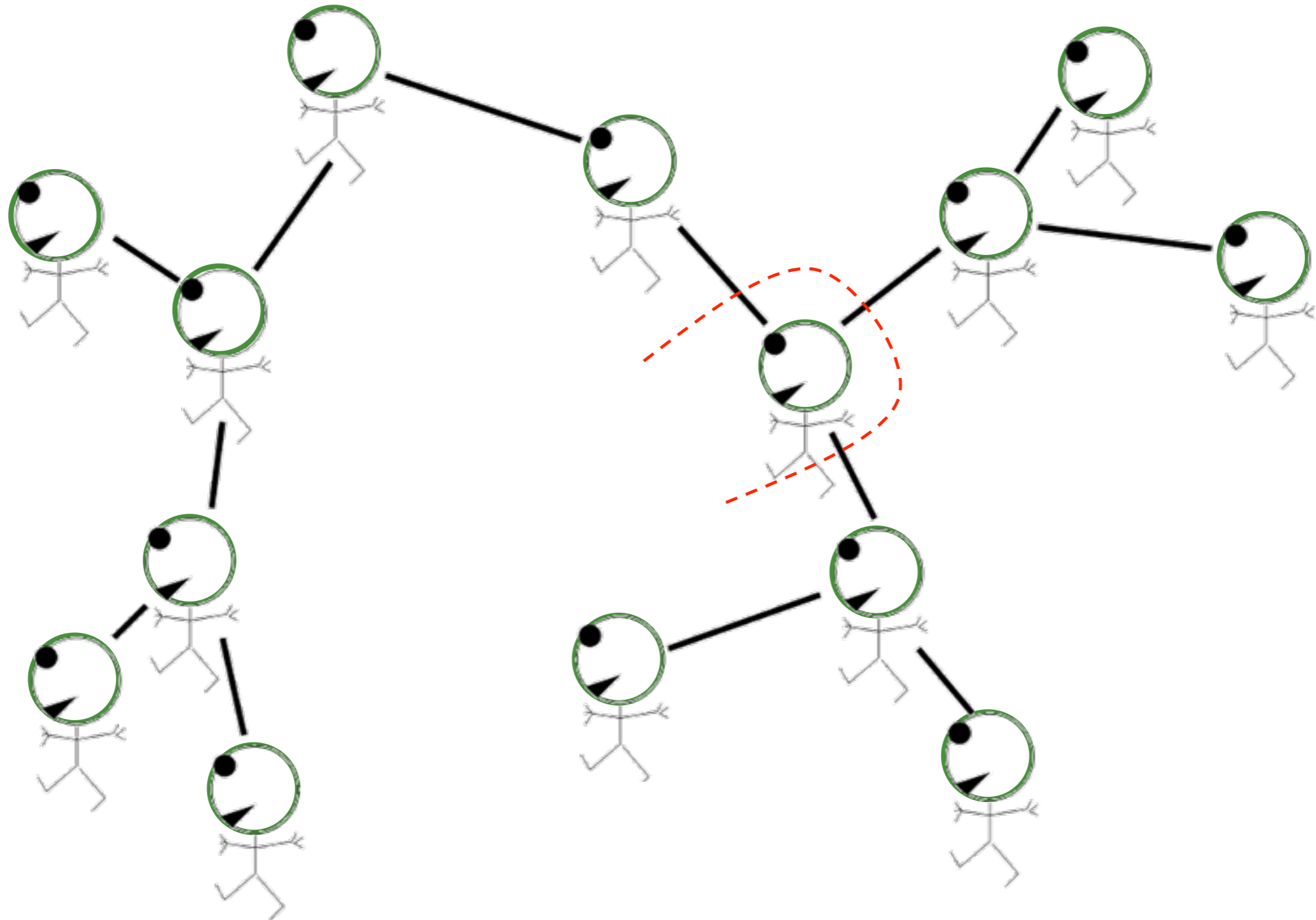

adapted from MacKay (2003) textbook

Great Ideas in ML: Message Passing

Each soldier receives reports from all branches of tree

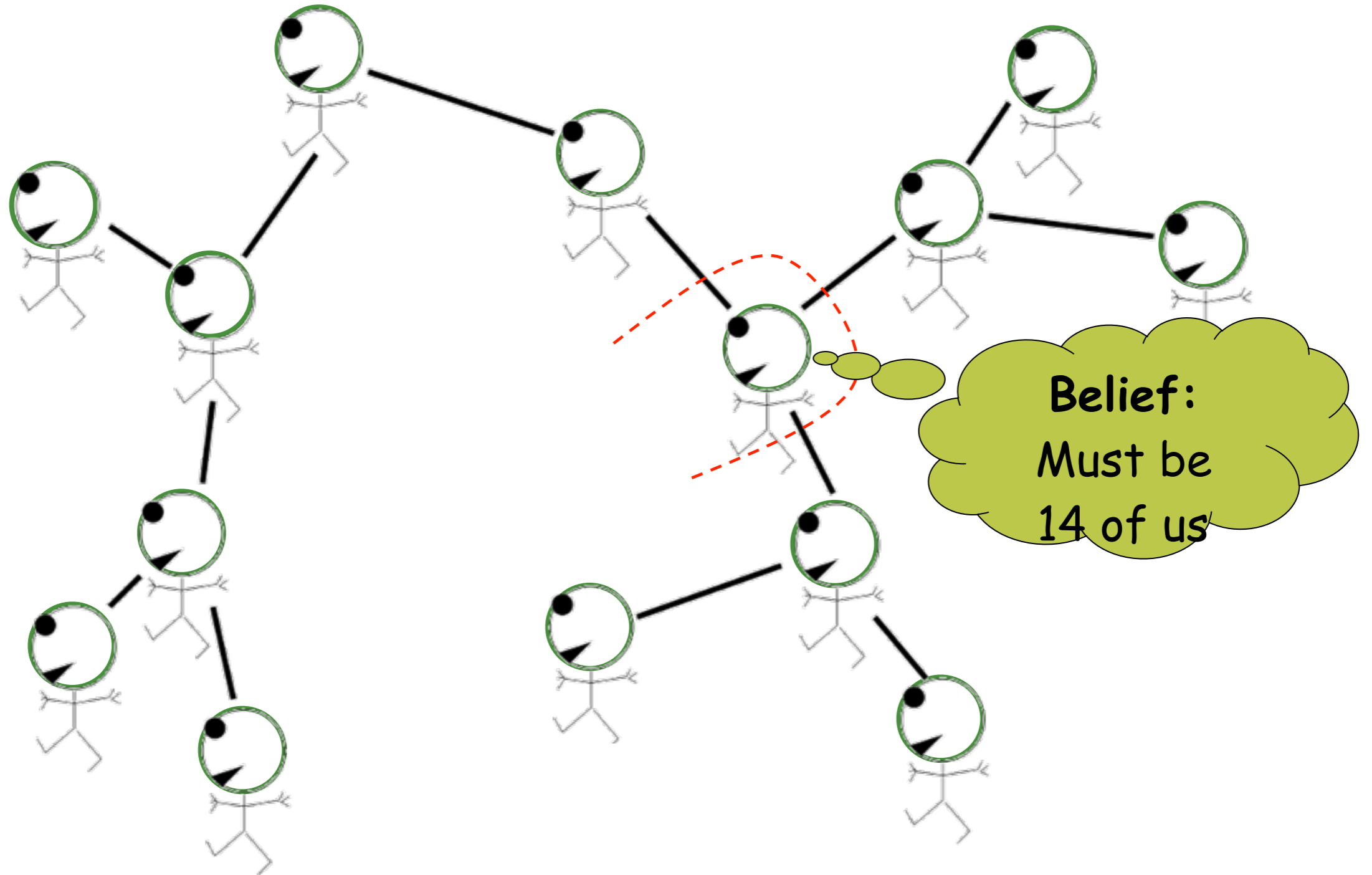

adapted from MacKay (2003) textbook

Great Ideas in ML: Message Passing

Each soldier receives reports from all branches of tree

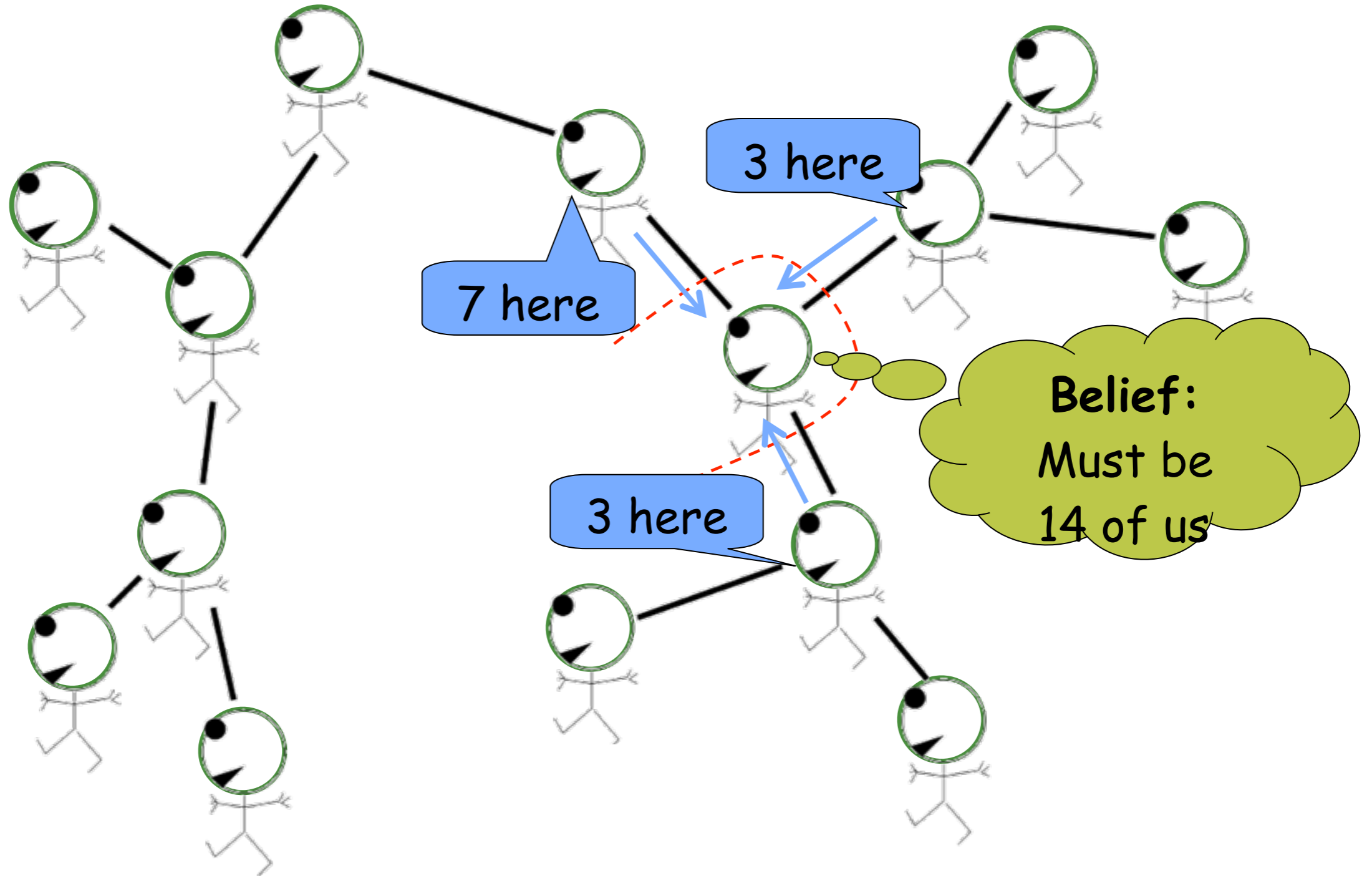

adapted from MacKay (2003) textbook

Great Ideas in ML: Message Passing

Each soldier receives reports from all branches of tree

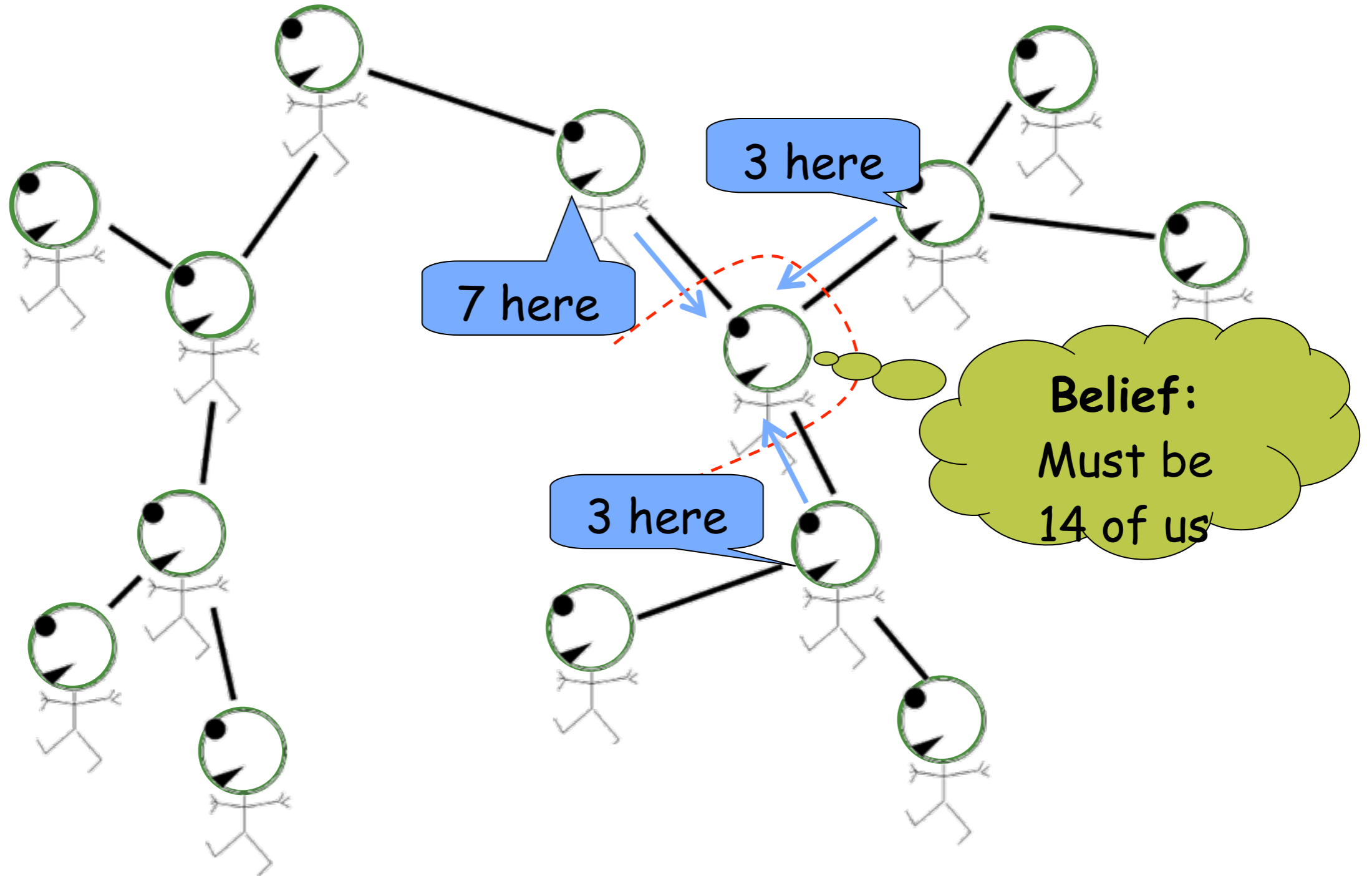

adapted from MacKay (2003) textbook

Great Ideas in ML: Message Passing

Each soldier receives reports from all branches of tree

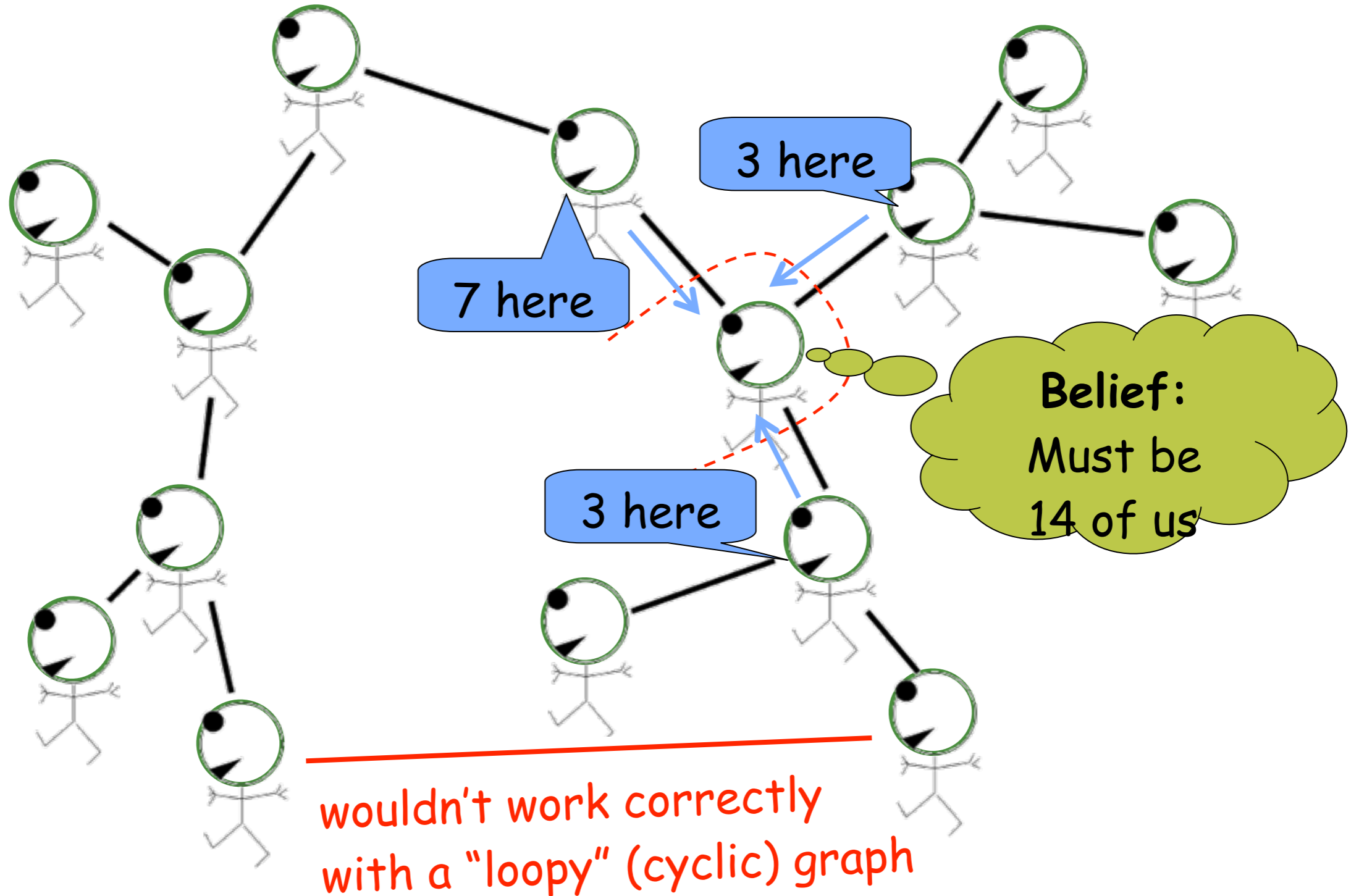

adapted from MacKay (2003) textbook

Great ideas in ML: Forward-Backward

- In the CRF, message passing = forward-backward = “sum-product algorithm”

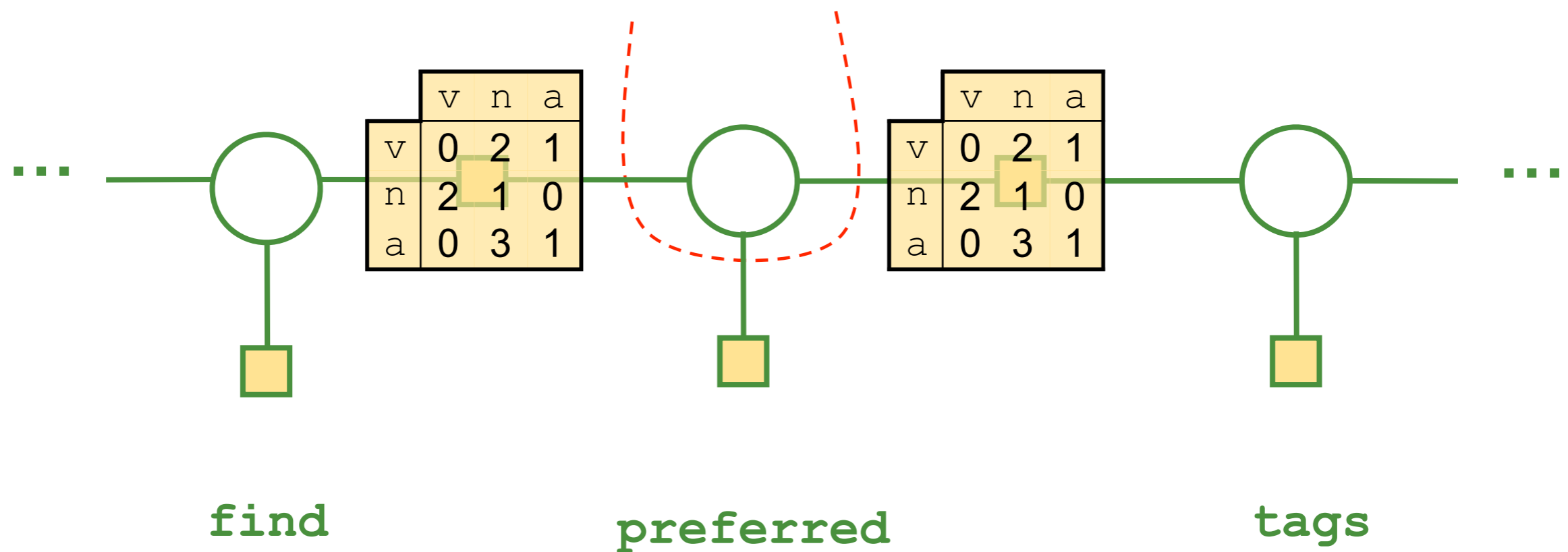

Great ideas in ML: Forward-Backward

- In the CRF, message passing = forward-backward = “sum-product algorithm”

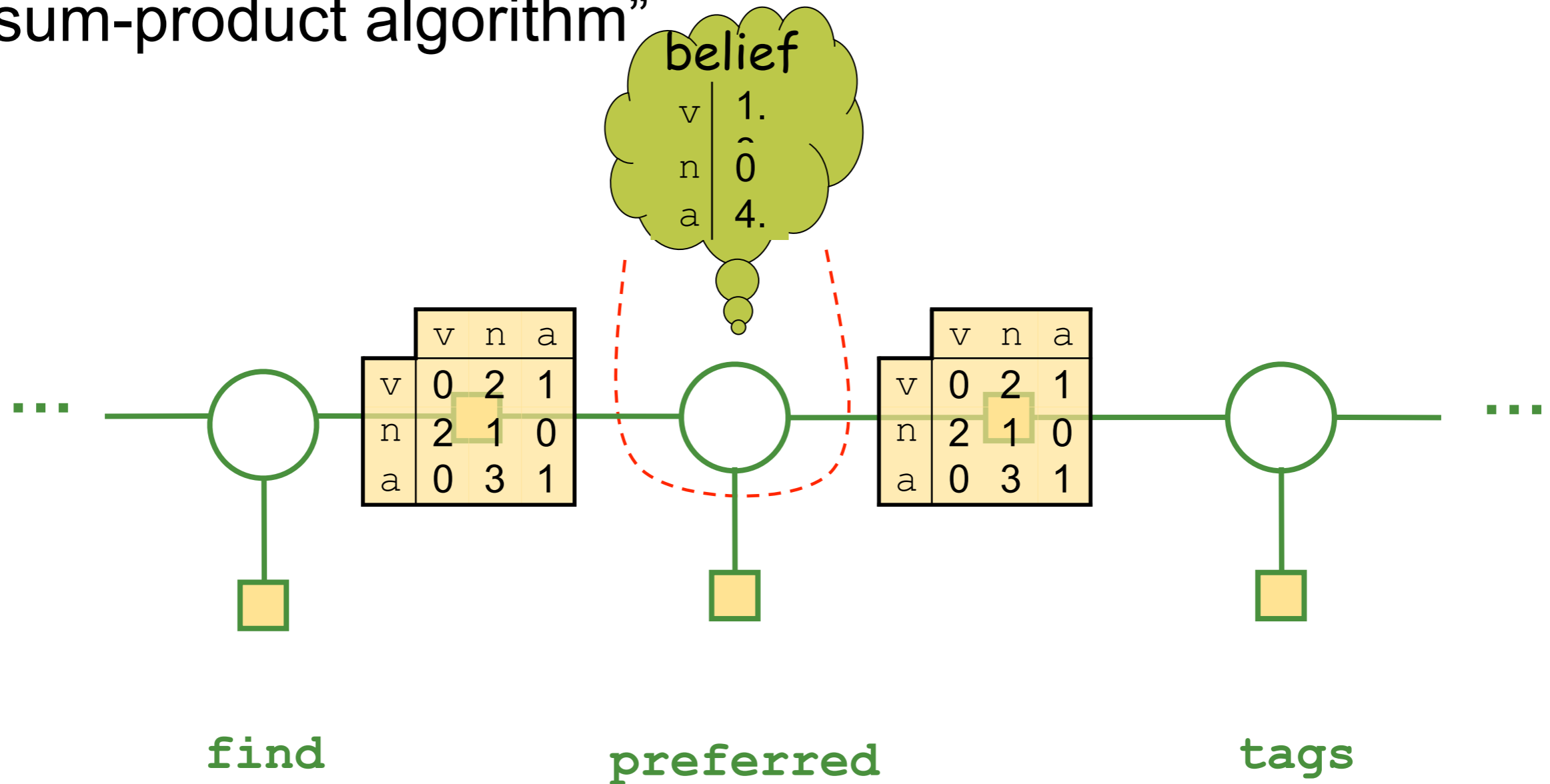

Great ideas in ML: Forward-Backward

- In the CRF, message passing = forward-backward = “sum-product algorithm”

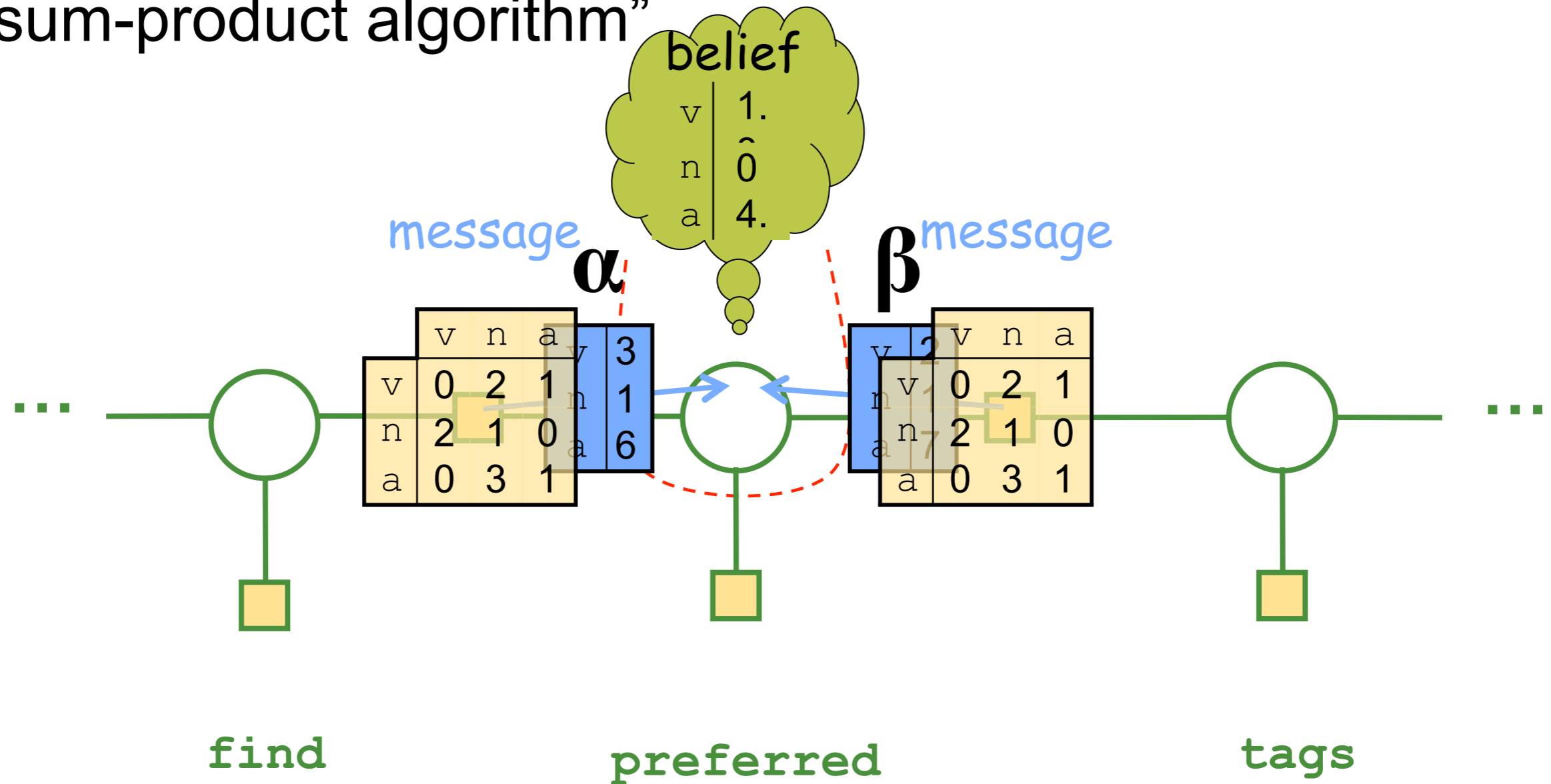

Great ideas in ML: Forward-Backward

- In the CRF, message passing = forward-backward = “sum-product algorithm”

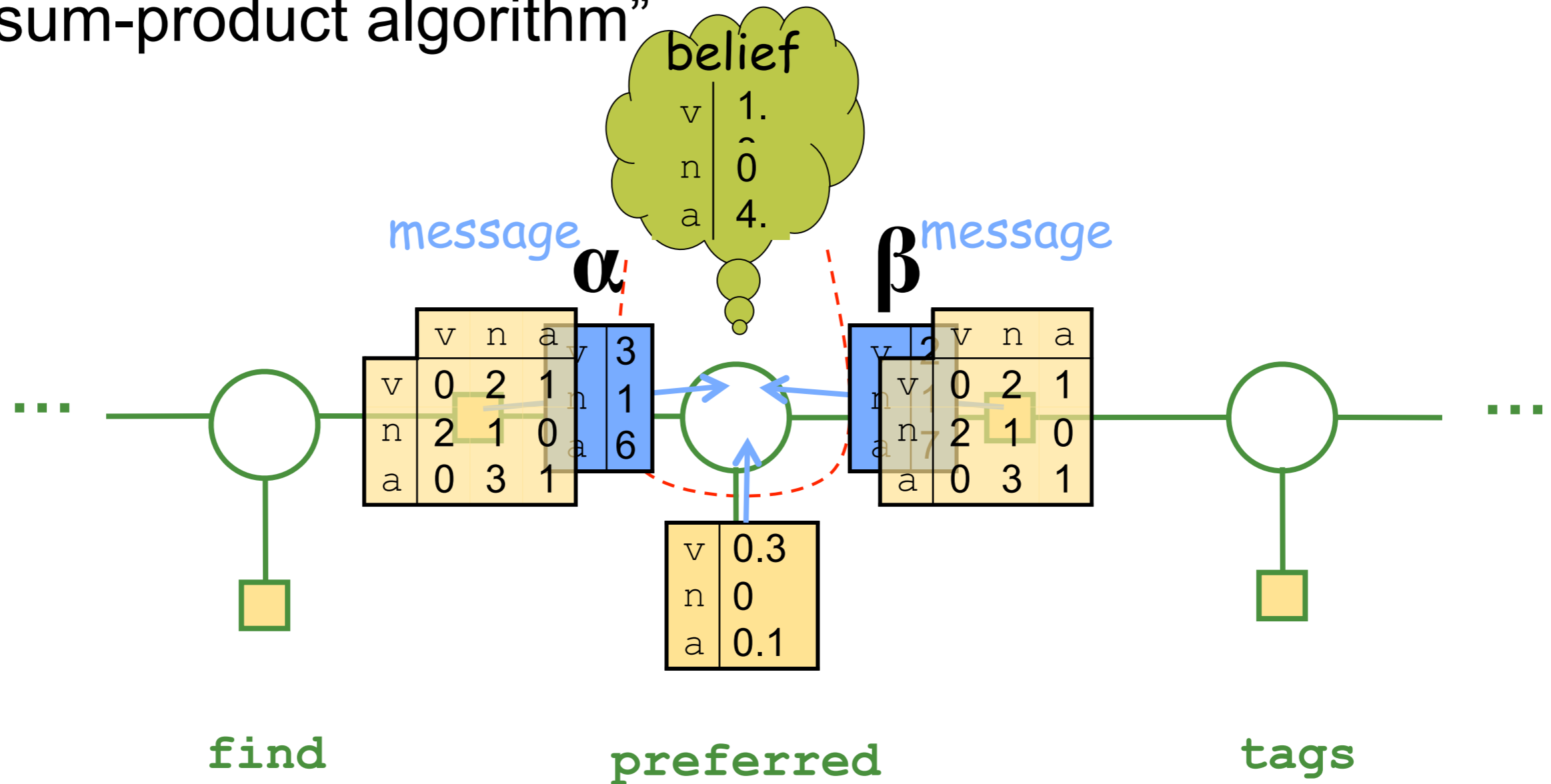

Great ideas in ML: Forward-Backward

- In the CRF, message passing = forward-backward = “sum-product algorithm”

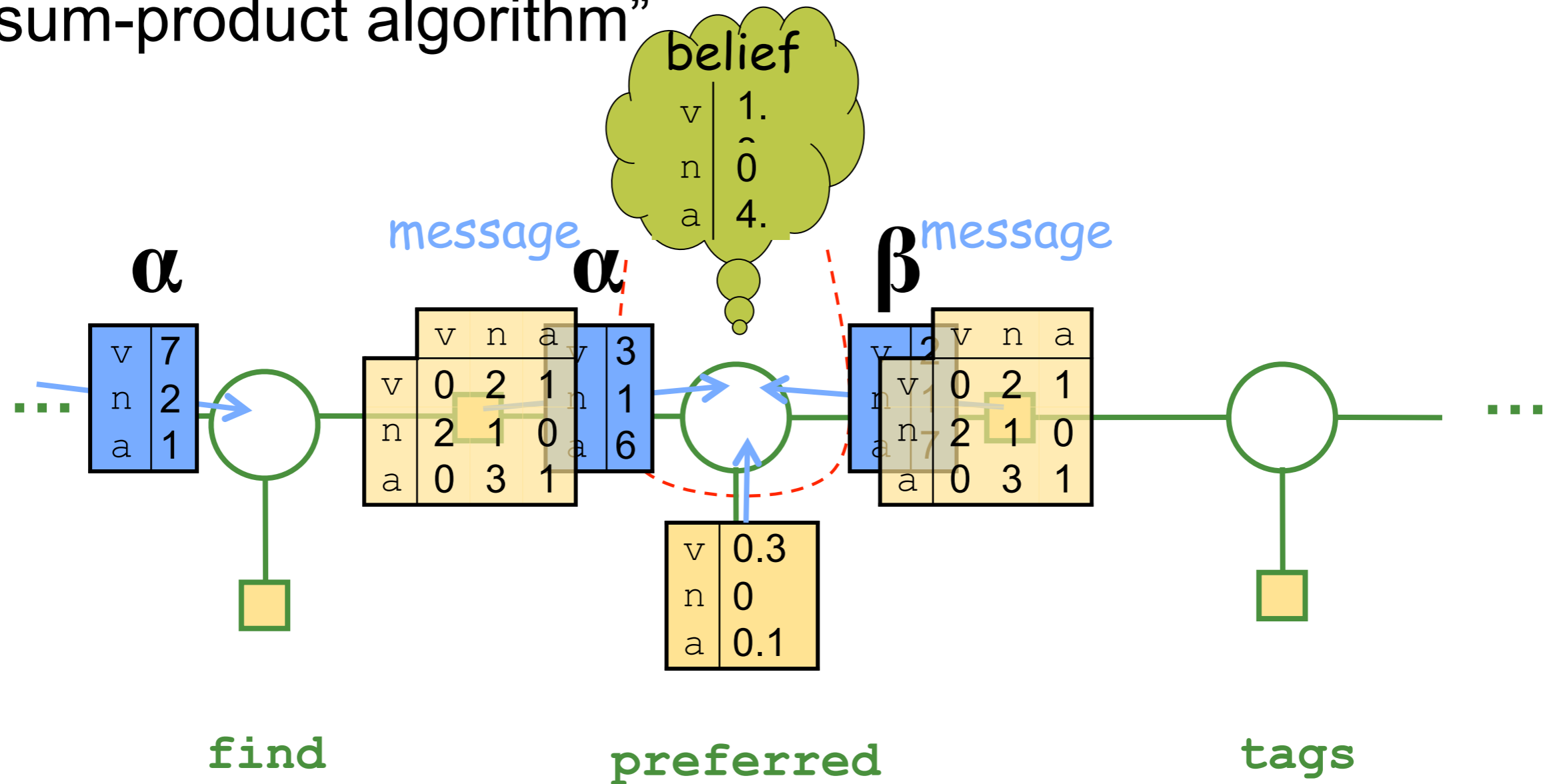

Great ideas in ML: Forward-Backward

- In the CRF, message passing = forward-backward = “sum-product algorithm”

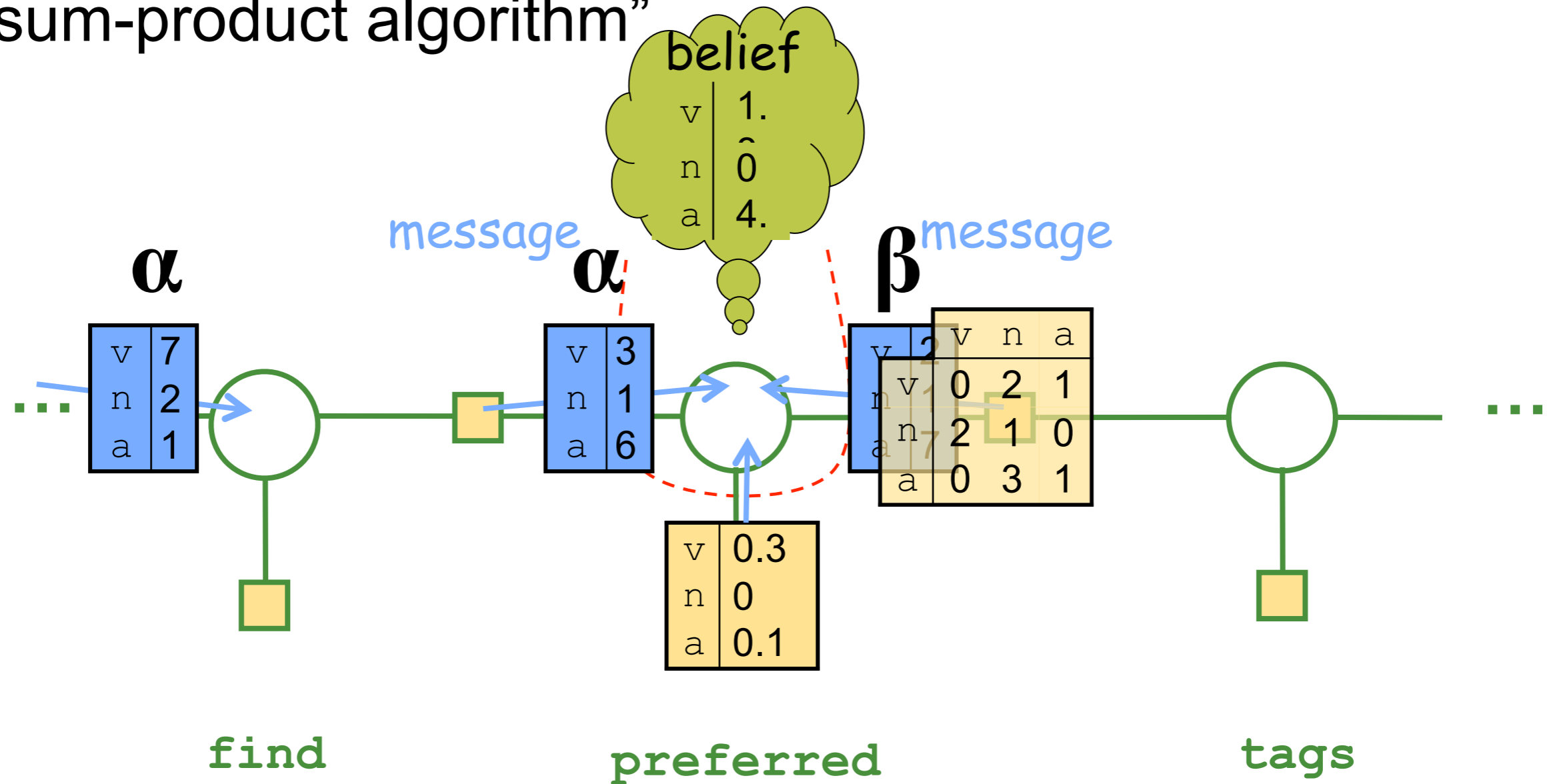

Great ideas in ML: Forward-Backward

- In the CRF, message passing = forward-backward = “sum-product algorithm”

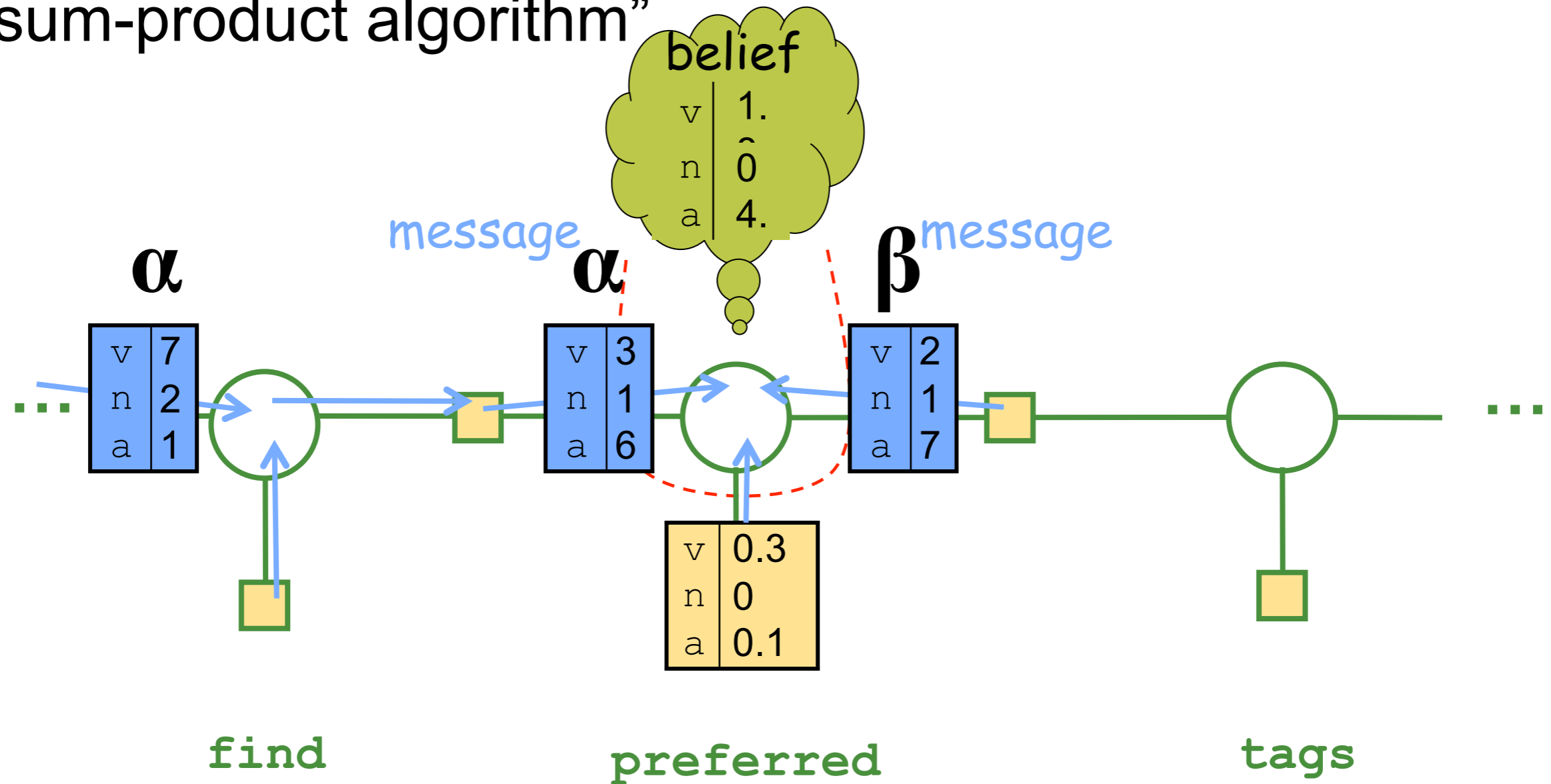

Great ideas in ML: Forward-Backward

- In the CRF, message passing = forward-backward = “sum-product algorithm”

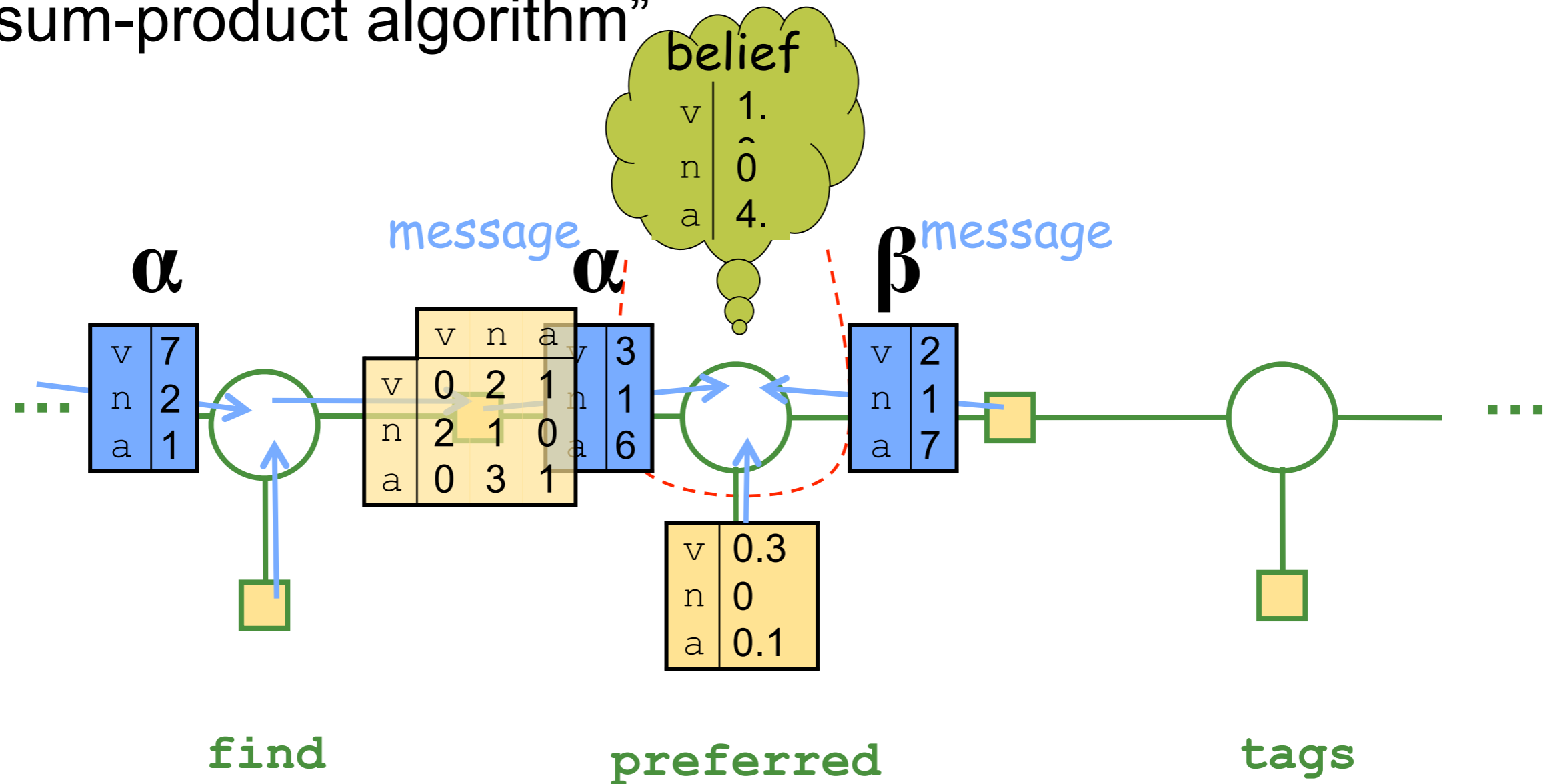

Great ideas in ML: Forward-Backward

- In the CRF, message passing = forward-backward = “sum-product algorithm”

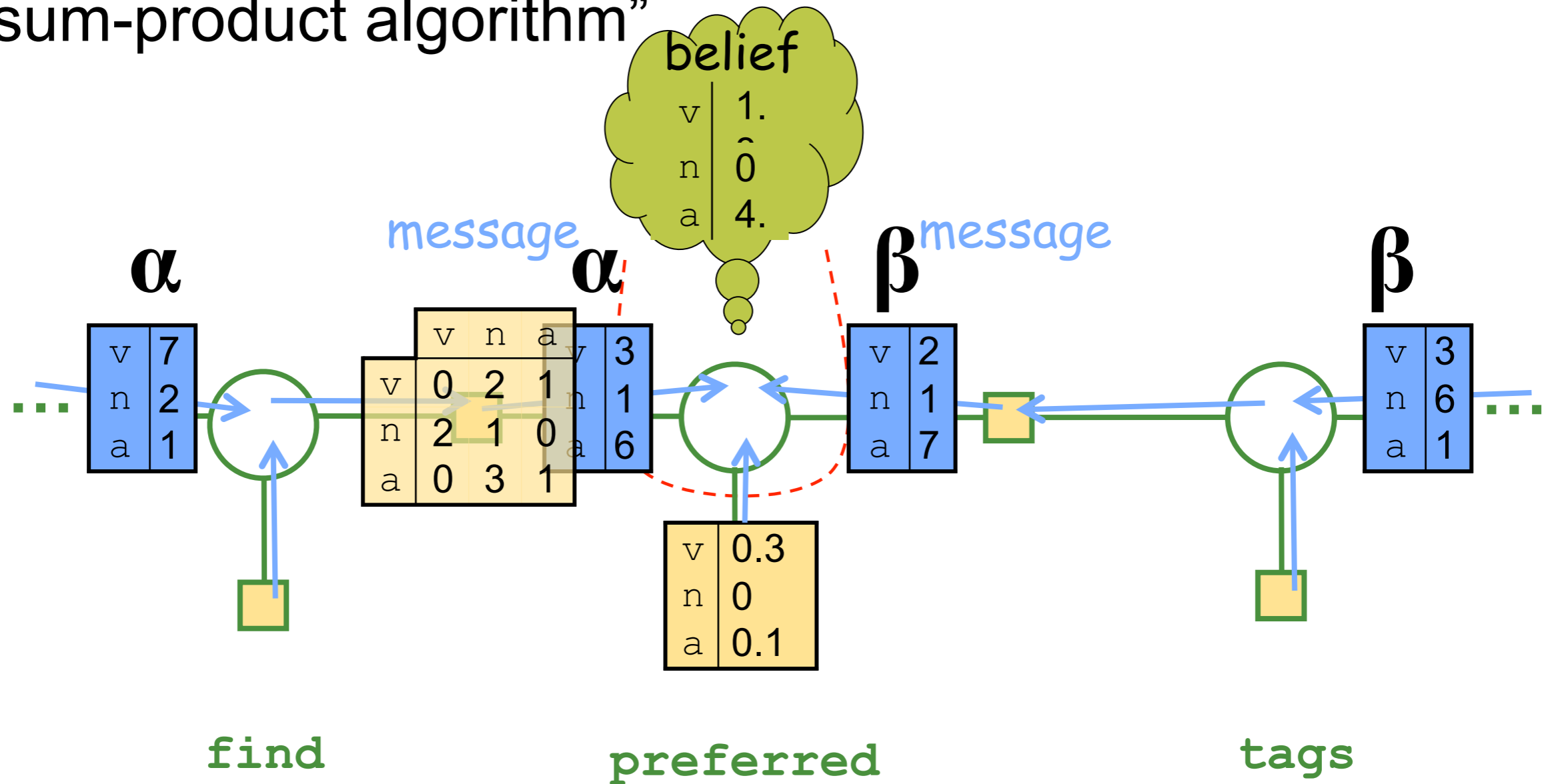

Great ideas in ML: Forward-Backward

- In the CRF, message passing = forward-backward = “sum-product algorithm”

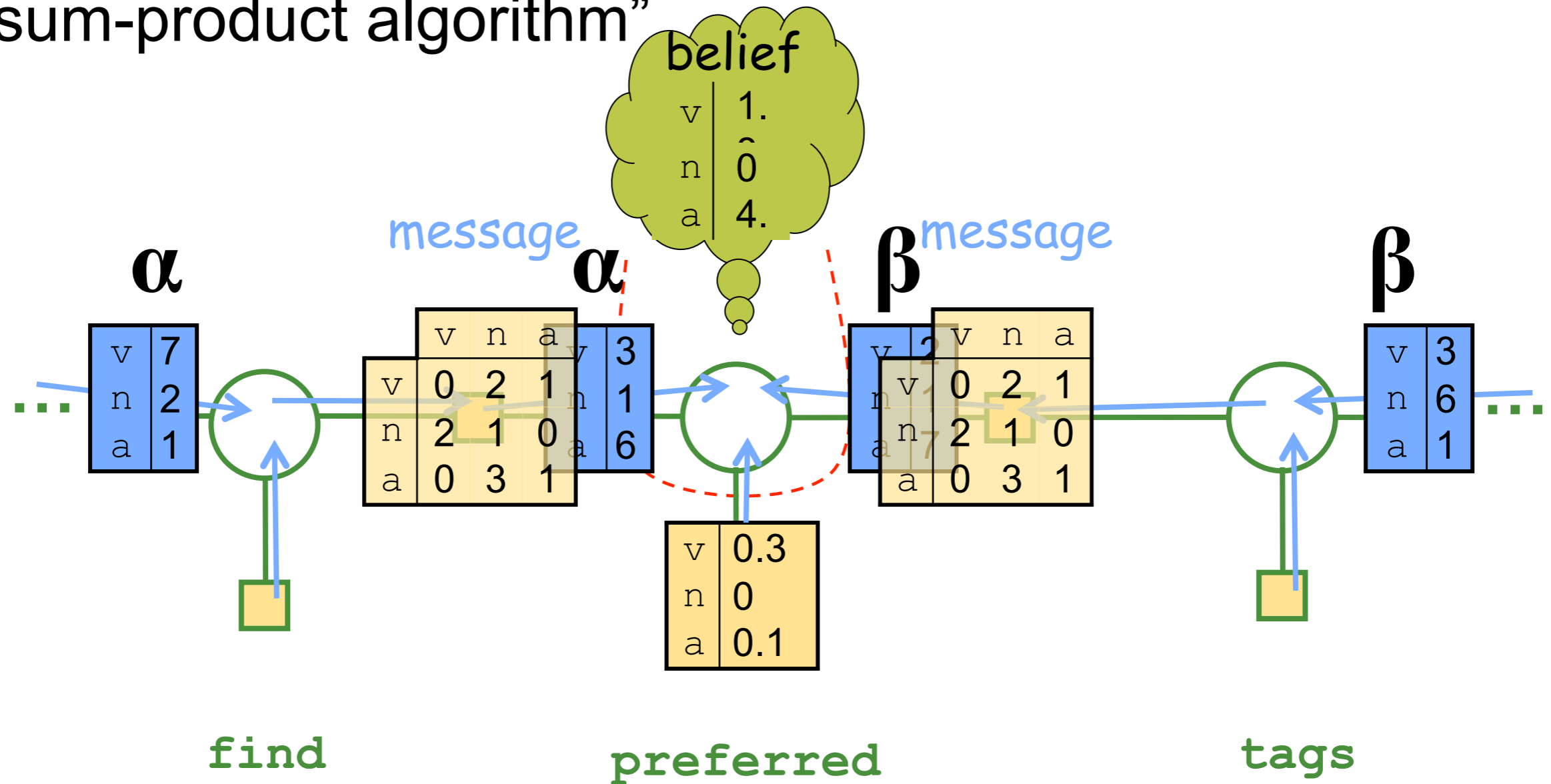

Sum-Product Equations

- Message from variable v to factor f

$$m_{v \rightarrow f}(x) = \prod_{f' \in N(v) \setminus \{f\}} m_{f' \rightarrow v}(x)$$

- Message from factor f to variable v

$$m_{f \rightarrow v}(x) = \sum_{N(f) \setminus \{v\}} \left[f(x_m) \prod_{v' \in N(f) \setminus \{v\}} m_{v' \rightarrow f}(y) \right]$$

Great ideas in ML: Forward-Backward

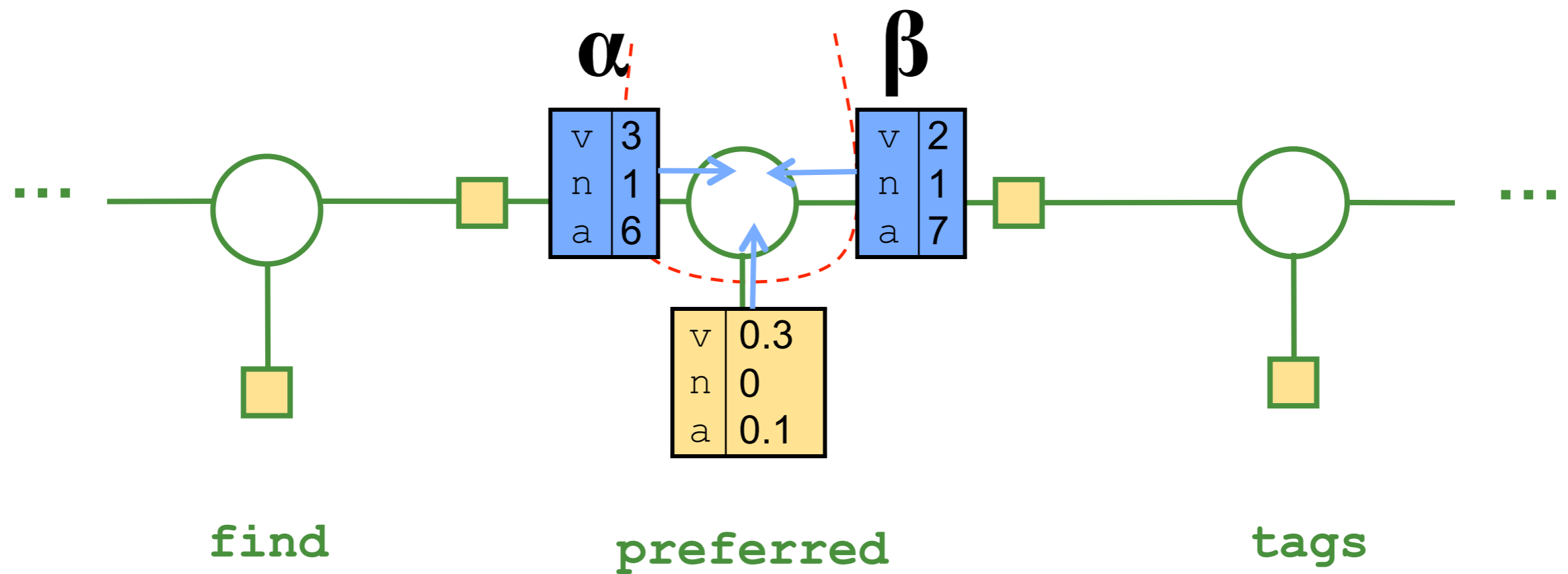

Great ideas in ML: Forward-Backward

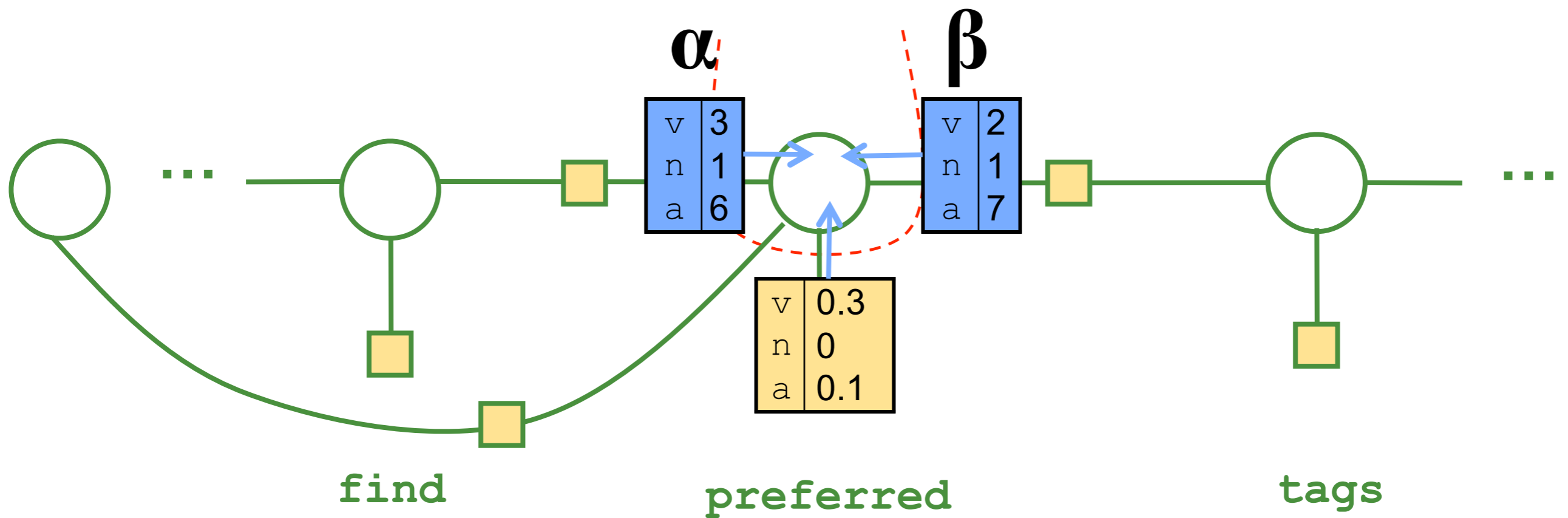

Great ideas in ML: Forward-Backward

- Extend CRF to “skip chain” to capture non-local factor

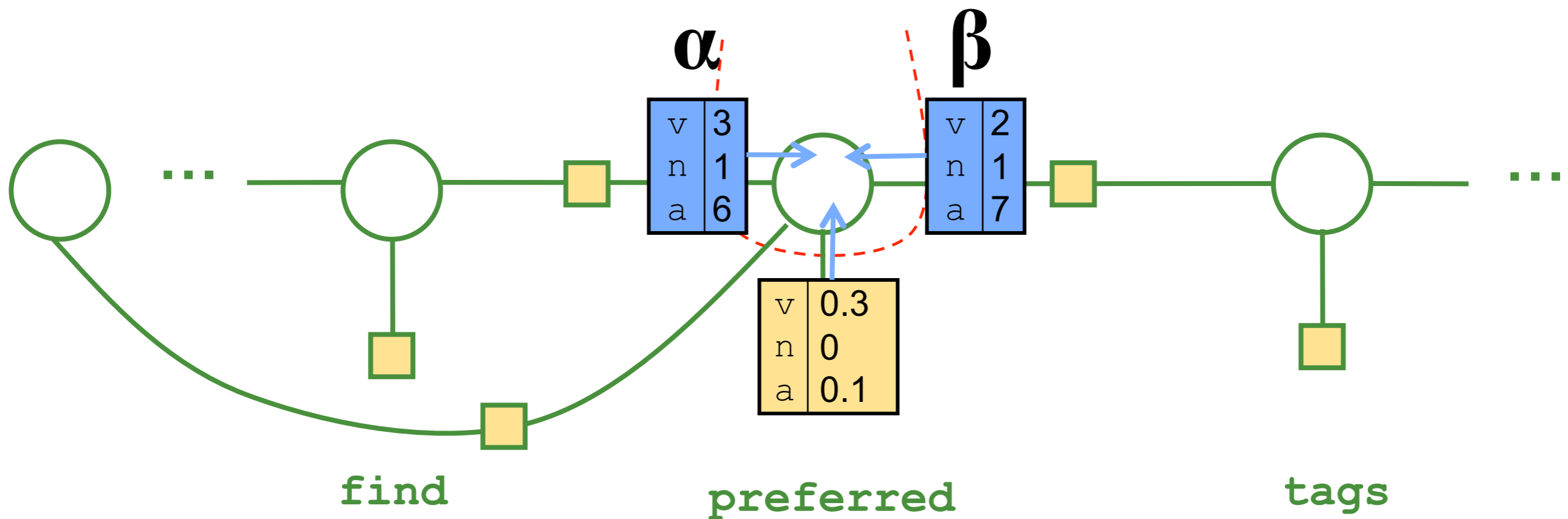

Great ideas in ML: Forward-Backward

- Extend CRF to “skip chain” to capture non-local factor
 - More influences on belief 😊

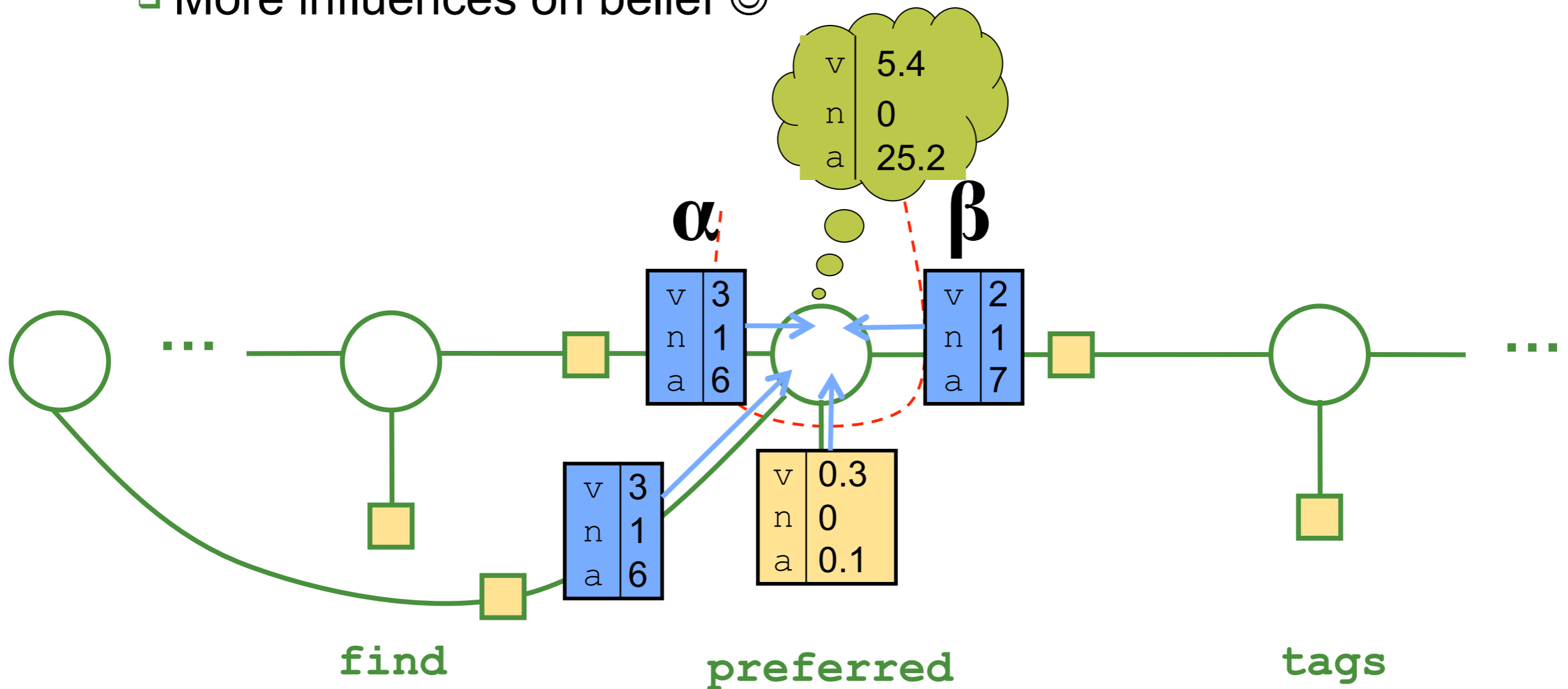

Great ideas in ML: Forward-Backward

- Extend CRF to “skip chain” to capture non-local factor
 - More influences on belief 😊
 - Graph becomes loopy 😞

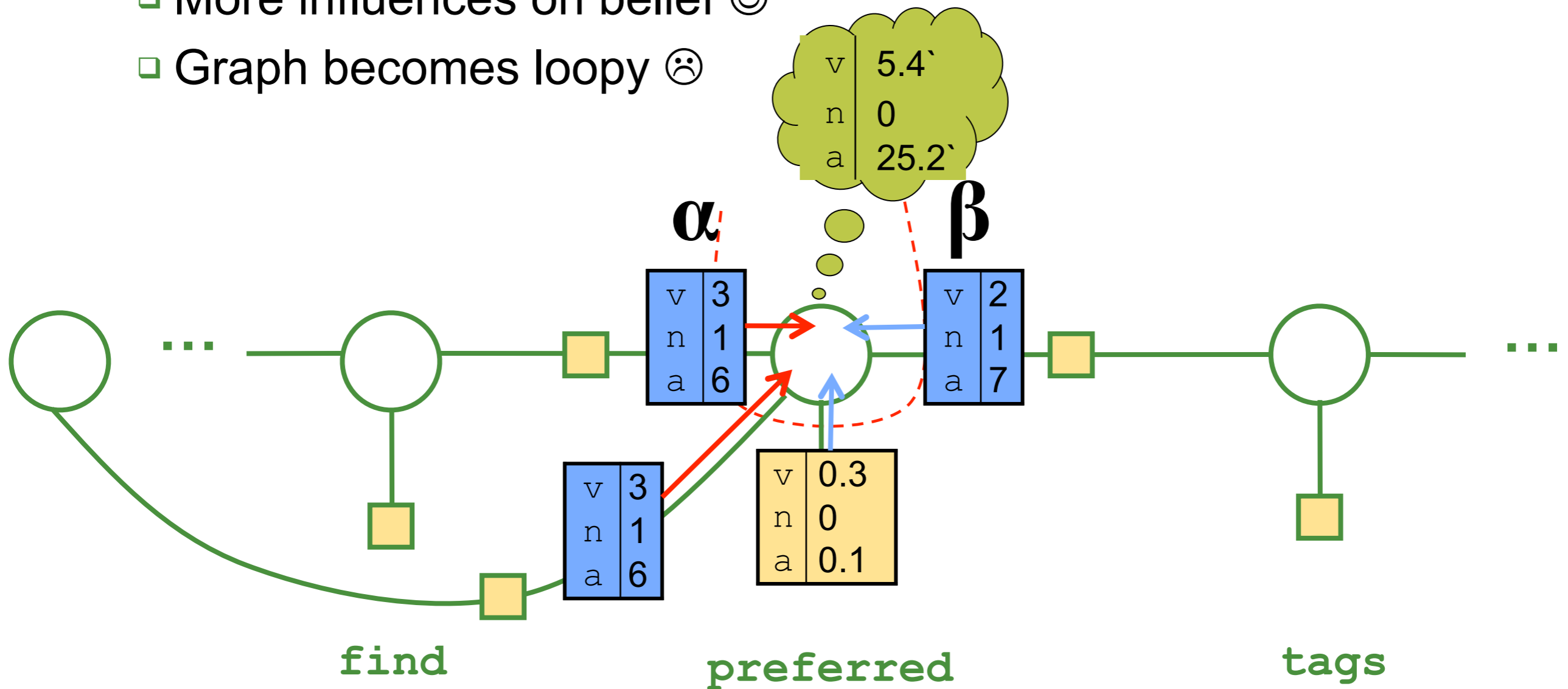

Great ideas in ML: Forward-Backward

- Extend CRF to “skip chain” to capture non-local factor

- More influences on belief 😊
- Graph becomes loopy 😞

Red messages not independent?
Pretend they are!

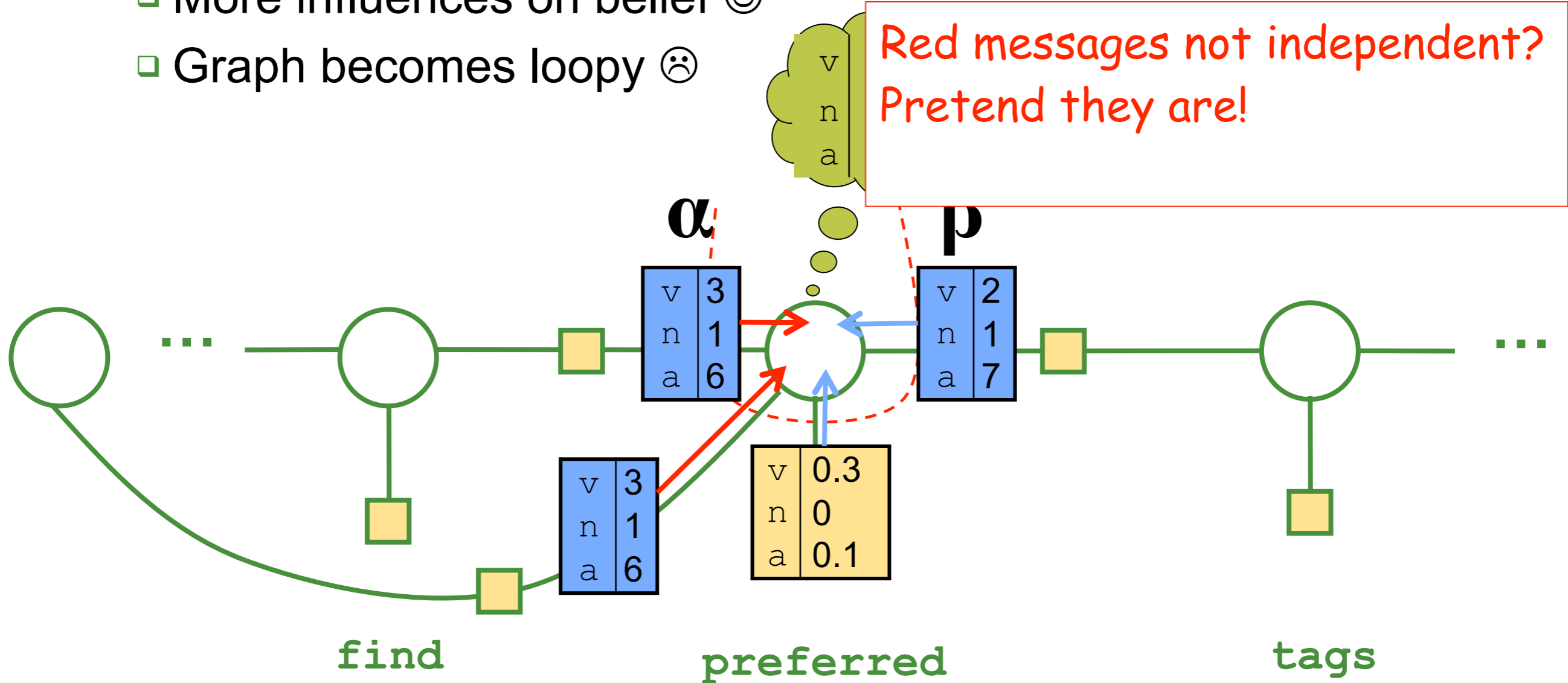

Great ideas in ML: Forward-Backward

- Extend CRF to “skip chain” to capture non-local factor

- More influences on belief 😊
- Graph becomes loopy 😞

Red messages not independent?
Pretend they are!
“Loopy Belief Propagation”

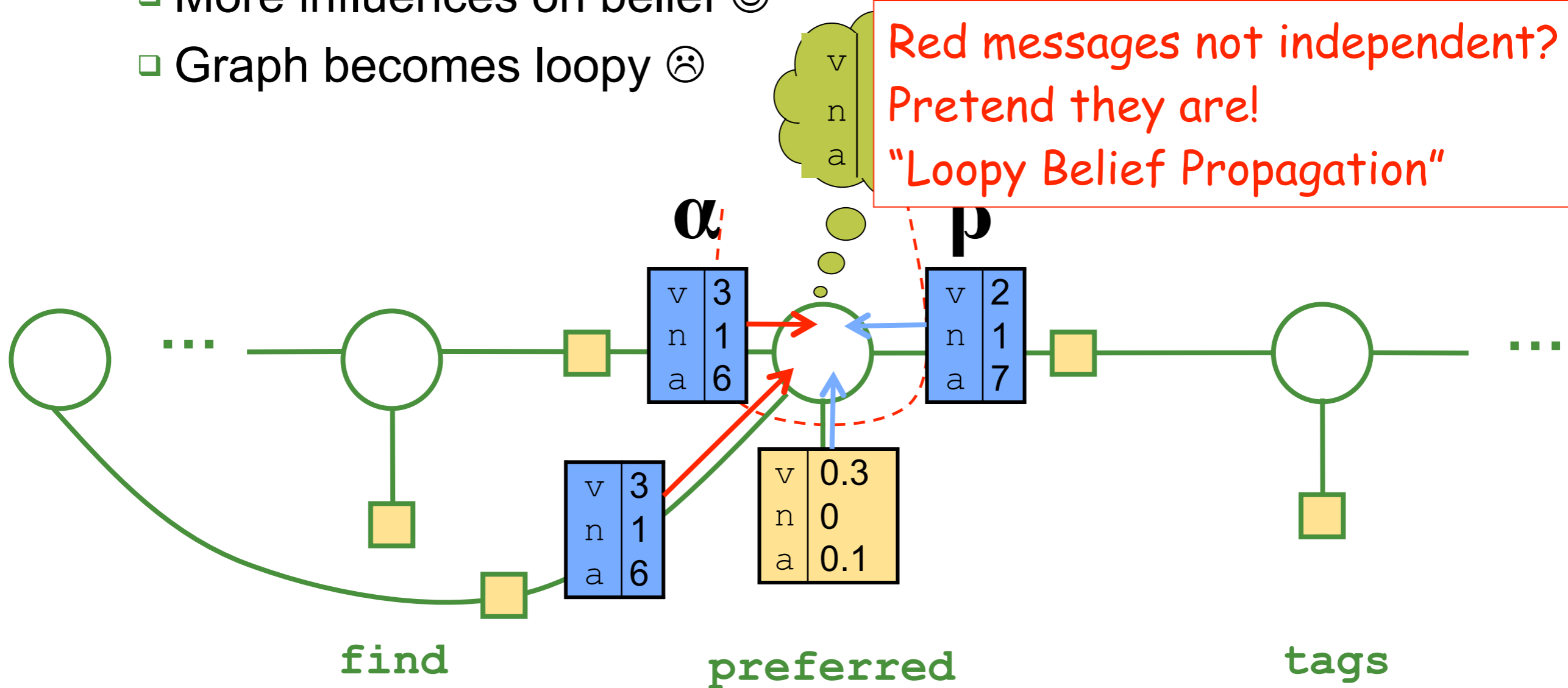

Terminological Clarification

`propagation`

Terminological Clarification

belief propagation

Terminological Clarification



Terminological Clarification



Terminological Clarification

loopy belief propagation



Terminological Clarification

{ loopy belief } propagation

loopy { belief propagation }



Terminological Clarification

{ loopy belief } propagation

loopy { belief propagation }

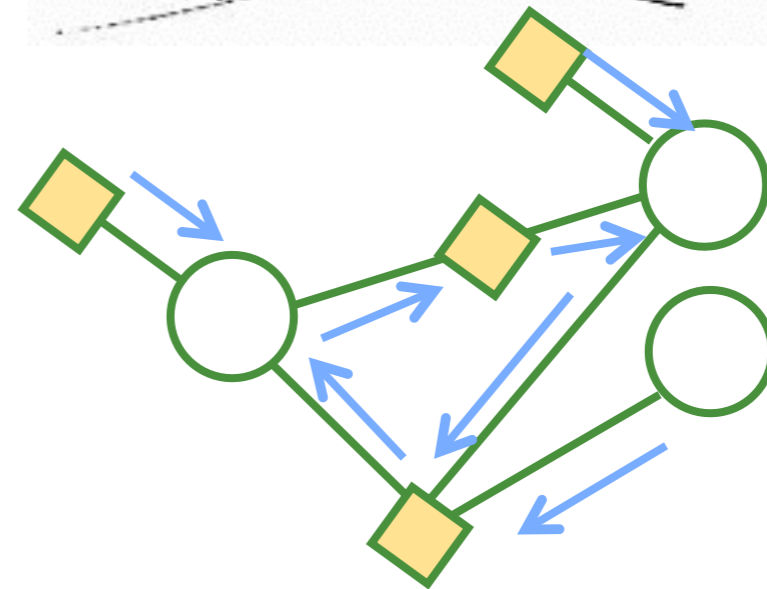

Propagating Global Factors

- Loopy belief propagation is easy for local factors
- How do combinatorial factors (like TREE) compute the message to the link in question?
 - ❖ “Does the TREE factor think the link is probably t given the messages it receives from *all* the other links?”

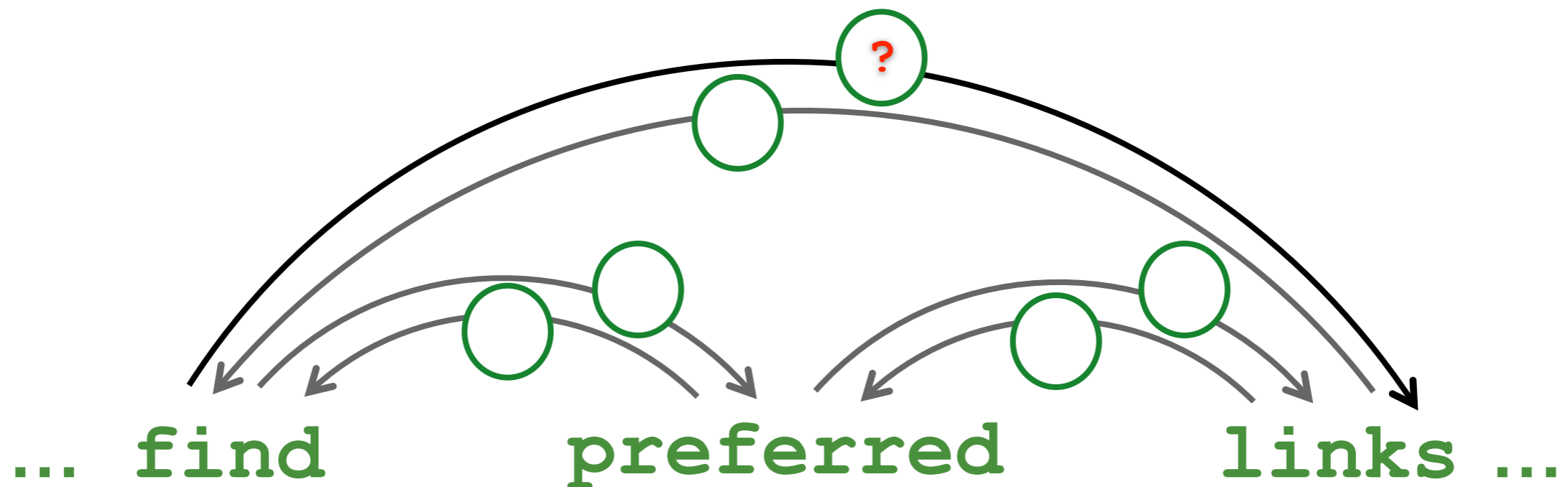

Propagating Global Factors

- Loopy belief propagation is easy for local factors
- How do combinatorial factors (like TREE) compute the message to the link in question?
 - ❖ “Does the TREE factor think the link is probably t given the messages it receives from *all* the other links?”

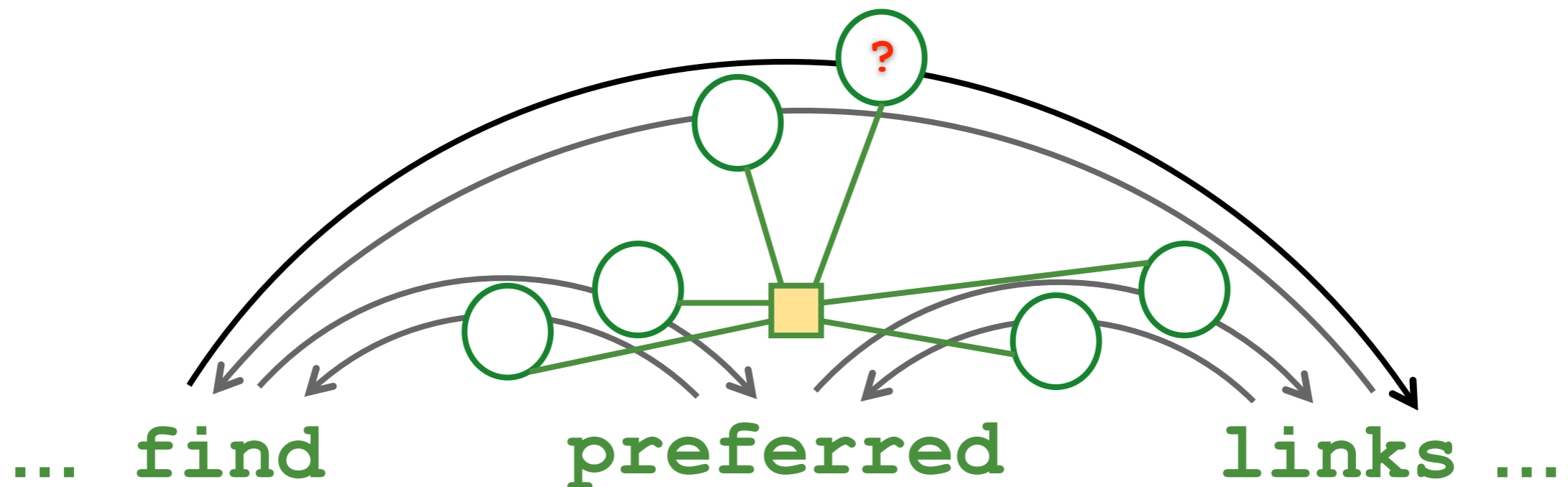

Propagating Global Factors

- Loopy belief propagation is easy for local factors
- How do combinatorial factors (like TREE) compute the message to the link in question?
 - ❖ “Does the TREE factor think the link is probably **t** given the messages it receives from *all* the other links?”

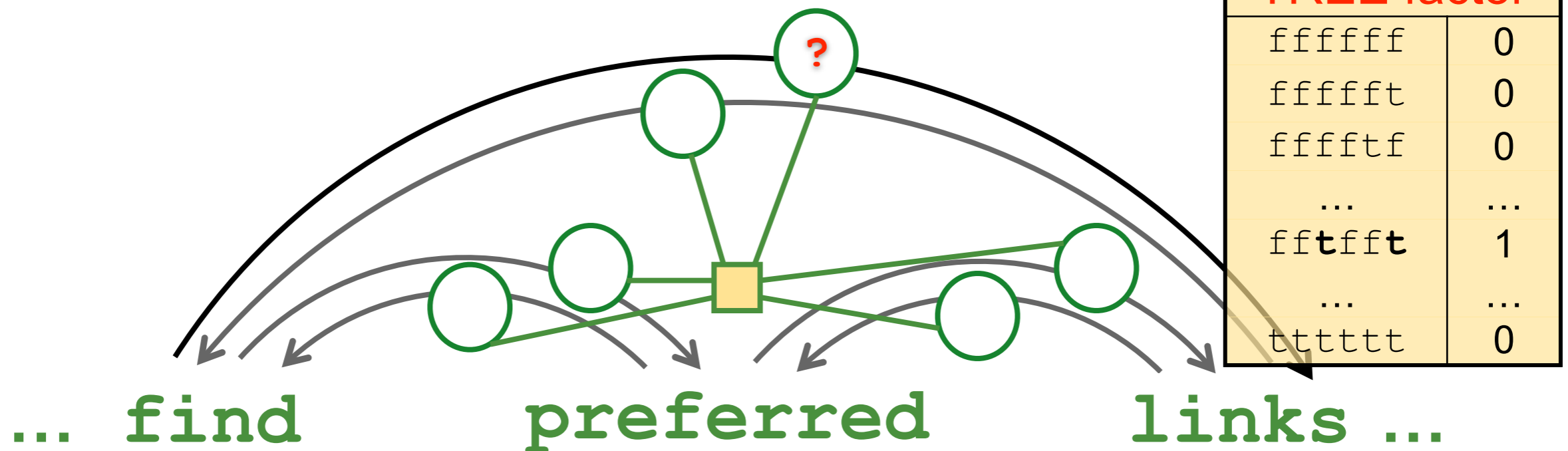

Propagating Global Factors

- How does the TREE factor compute the message to the link in question?
 - ❖ “Does the TREE factor think the link is probably **t** given the messages it receives from *all* the other links?”

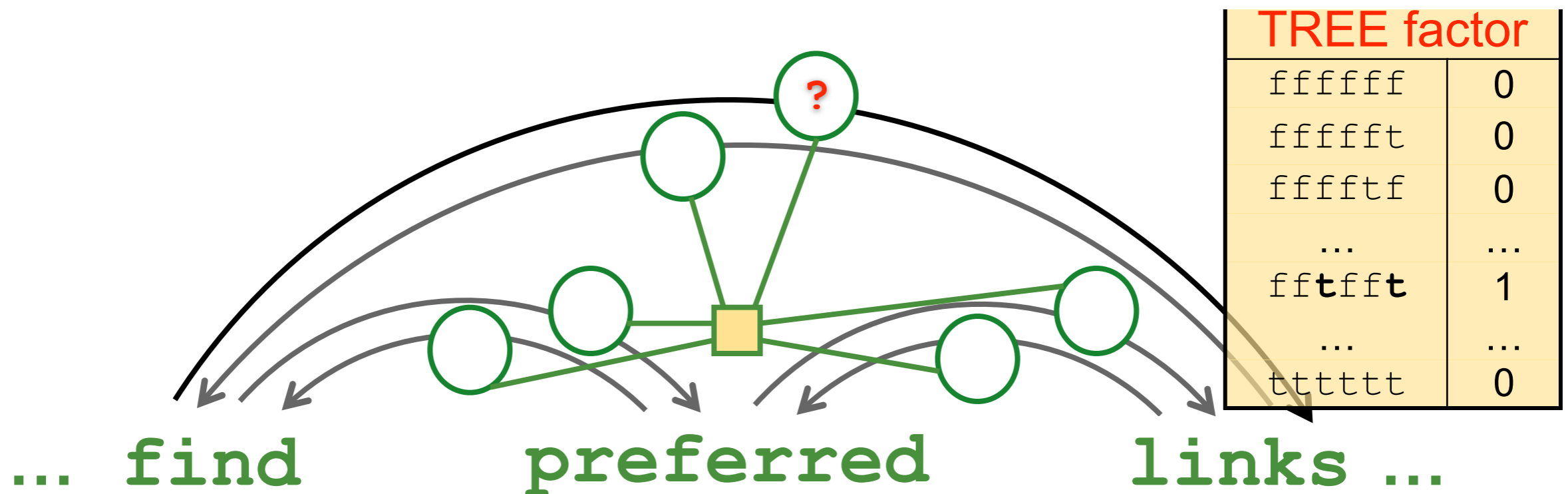

Propagating Global Factors

- How does the TREE factor compute the message to the link in question?
 - ❖ “Does the TREE factor think the link is probably t given the messages it receives from *all* the other links?”

Old-school parsing to the rescue!

This is the outside probability of the link in an *edge-factored* parser!

∴ TREE factor computes all outgoing messages at once
(given all incoming messages)

Projective case: total $O(n^3)$ time by inside-outside

Non-projective: total $O(n^3)$ time by inverting Kirchhoff matrix

Graph Theory to the Rescue!

Tutte's Matrix-Tree Theorem (1948)

The **determinant** of the Kirchoff (aka Laplacian) adjacency matrix of directed graph G without row and column r is equal to the **sum of scores of all directed spanning trees** of G rooted at node r .



Graph Theory to the Rescue!

Tutte's Matrix-Tree Theorem (1948)

The **determinant** of the Kirchoff (aka Laplacian) adjacency matrix of directed graph G without row and column r is equal to the **sum of scores of all directed spanning trees** σ rooted at node r .

Exactly the Z we need!



Graph Theory to the Rescue!

$O(n^3)$ time!

Tu Matrix-Tree Theorem (1948)

The **determinant** of the Kirchoff (aka Laplacian) adjacency matrix of directed graph G without row and column r is equal to the **sum of scores of all directed spanning trees** σ rooted at node r .

Exactly the Z we need!





Kirchoff (Laplacian) Matrix



$$\begin{bmatrix} 0 & -s(1,0) & -s(2,0) & \cdots & -s(n,0) \\ 0 & 0 & -s(2,1) & \cdots & -s(n,1) \\ 0 & -s(1,2) & 0 & \cdots & -s(n,2) \\ \vdots & \vdots & \vdots & \ddots & \vdots \\ 0 & -s(1,n) & -s(2,n) & \cdots & 0 \end{bmatrix}$$

- Negate edge scores
- Sum columns (children)
- Strike root row/col.
- Take determinant



Kirchoff (Laplacian) Matrix



$$\begin{bmatrix} 0 & -s(1,0) & -s(2,0) & \cdots & -s(n,0) \\ 0 & 0 & -s(2,1) & \cdots & -s(n,1) \\ 0 & -s(1,2) & 0 & \cdots & -s(n,2) \\ \vdots & \vdots & \vdots & \ddots & \vdots \\ 0 & -s(1,n) & -s(2,n) & \cdots & 0 \end{bmatrix}$$

- Negate edge scores
- Sum columns (children)
- Strike root row/col.
- Take determinant



Kirchoff (Laplacian) Matrix



$$\begin{bmatrix} 0 & -s(1,0) & -s(2,0) & \cdots & -s(n,0) \\ 0 & \sum_{j \neq 1} s(1,j) & -s(2,1) & \cdots & -s(n,1) \\ 0 & -s(1,2) & \sum_{j \neq 2} s(2,j) & \cdots & -s(n,2) \\ \vdots & \vdots & \vdots & \ddots & \vdots \\ 0 & -s(1,n) & -s(2,n) & \cdots & \sum_{j \neq n} s(n,j) \end{bmatrix}$$

- Negate edge scores
- Sum columns (children)
- Strike root row/col.
- Take determinant



Kirchoff (Laplacian) Matrix



$$\begin{vmatrix} \sum_{j \neq 1} s(1, j) & -s(2, 1) & \cdots & -s(n, 1) \\ -s(1, 2) & \sum_{j \neq 2} s(2, j) & \cdots & -s(n, 2) \\ \vdots & \vdots & \ddots & \vdots \\ -s(1, n) & -s(2, n) & \cdots & \sum_{j \neq n} s(n, j) \end{vmatrix}$$

- Negate edge scores
- Sum columns (children)
- Strike root row/col.
- Take determinant



Kirchoff (Laplacian) Matrix



$$\begin{vmatrix} \sum_{j \neq 1} s(1, j) & -s(2, 1) & \cdots & -s(n, 1) \\ -s(1, 2) & \sum_{j \neq 2} s(2, j) & \cdots & -s(n, 2) \\ \vdots & \vdots & \ddots & \vdots \\ -s(1, n) & -s(2, n) & \cdots & \sum_{j \neq n} s(n, j) \end{vmatrix}$$

- Negate edge scores
- Sum columns (children)
- Strike root row/col.
- Take determinant

N.B.: This allows multiple children of root, but see Koo et al. 2007.

Transition-Based Parsing

- Linear time
- Online
- Train a classifier to predict next action
- Deterministic or beam-search strategies
- But... generally less accurate

Transition-Based Parsing

Arc-eager shift-reduce parsing (Nivre, 2003)

Start state: $([], [1, \dots, n], \{ \})$

Final state: $(S, [], A)$

Shift: $(S, i|B, A) \Rightarrow (S|i, B, A)$

Reduce: $(S|i, B, A) \Rightarrow (S, B, A)$

Right-Arc: $(S|i, j|B, A) \Rightarrow (S|i|j, B, A \cup \{i \rightarrow j\})$

Left-Arc: $(S|i, j|B, A) \Rightarrow (S, j|B, A \cup \{i \leftarrow j\})$

Transition-Based Parsing

Arc-eager shift-reduce parsing (Nivre, 2003)

Stack

[]_s

Buffer

[who, did, you, see]_B

Arcs

{ }

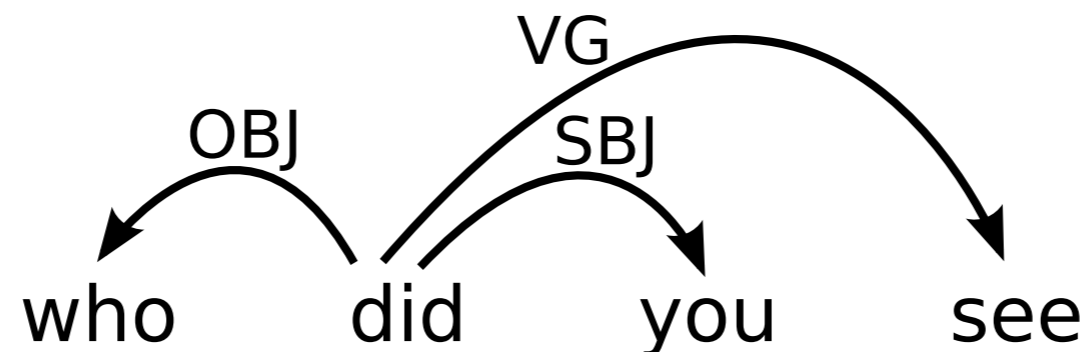

Transition-Based Parsing

Arc-eager shift-reduce parsing (Nivre, 2003)

Stack

[who]_S

Buffer

[did, you, see]_B

Arcs

{ }

Shift

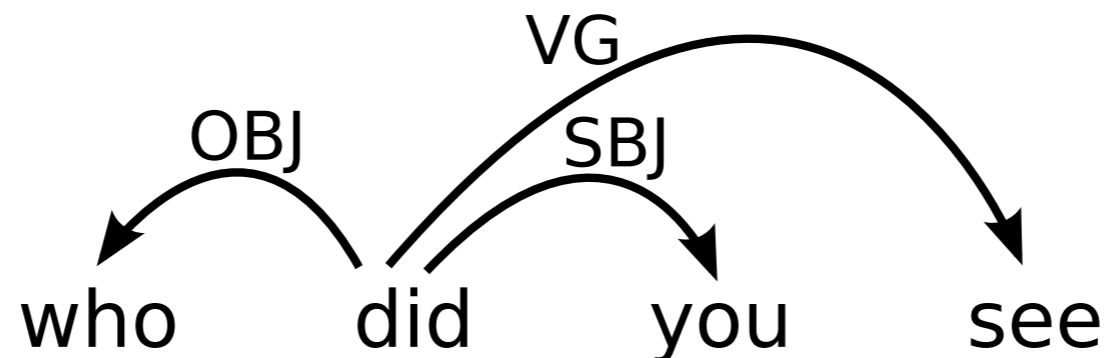

Transition-Based Parsing

Arc-eager shift-reduce parsing (Nivre, 2003)

Stack

[]_S

Buffer

[did, you, see]_B

Arcs

{ who $\xleftarrow{\text{OBJ}}$ did }

*Left-arc
OBJ*

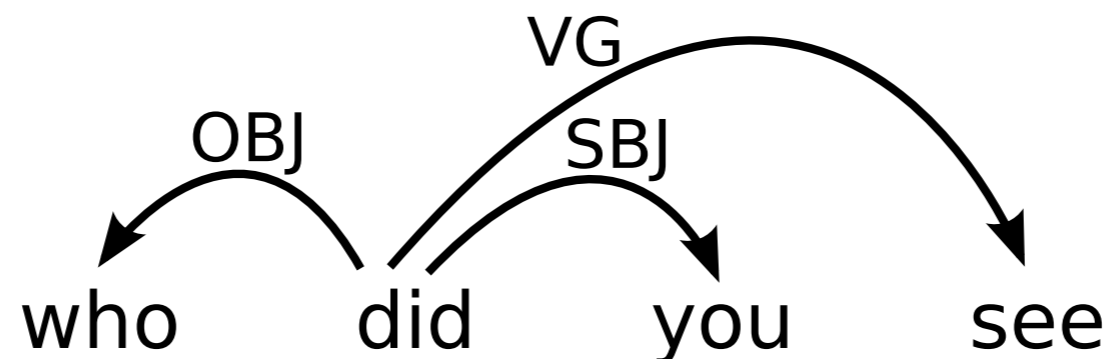

Transition-Based Parsing

Arc-eager shift-reduce parsing (Nivre, 2003)

Stack

[did]_S

Buffer

[you, see]_B

Arcs

{ who $\xleftarrow{\text{OBJ}}$ did }

Shift

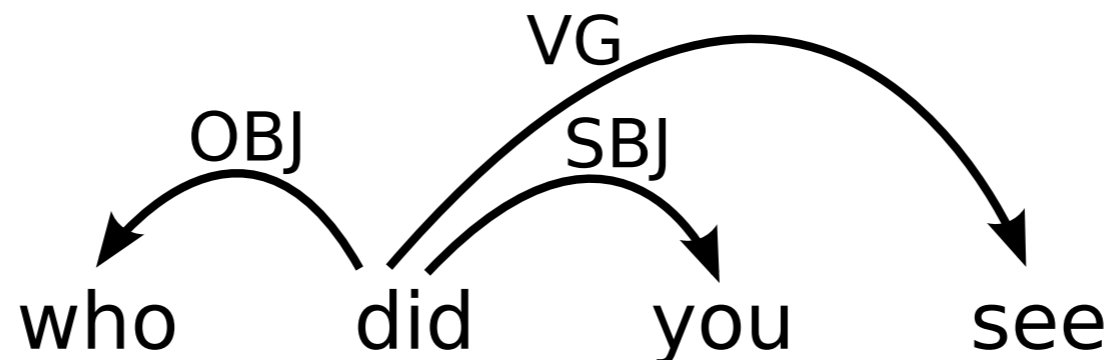

Transition-Based Parsing

Arc-eager shift-reduce parsing (Nivre, 2003)

Stack

[did, you]_S

Buffer

[see]_B

Arcs

{ who $\xleftarrow{\text{OBJ}}$ did,
did $\xrightarrow{\text{SBJ}}$ you }

Right-arc
SBJ

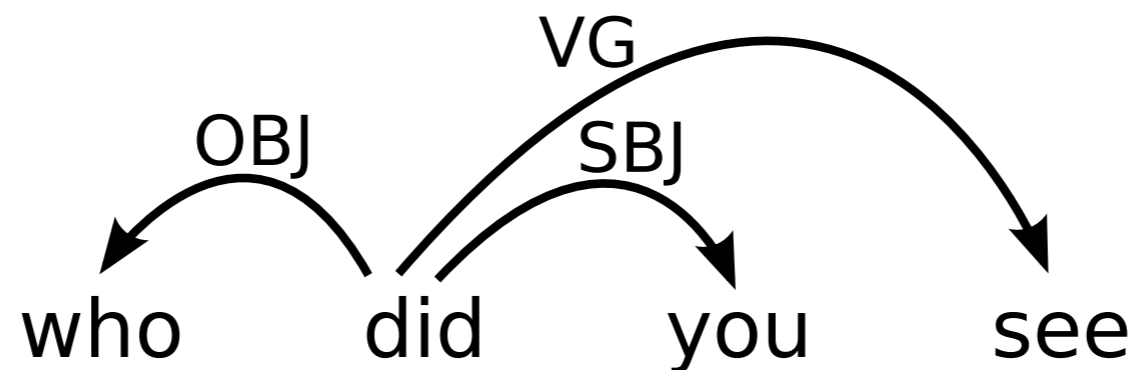

Transition-Based Parsing

Arc-eager shift-reduce parsing (Nivre, 2003)

Stack

[did]_S

Buffer

[see]_B

Arcs

{ who $\xleftarrow{\text{OBJ}}$ did,
did $\xrightarrow{\text{SBJ}}$ you }

Reduce

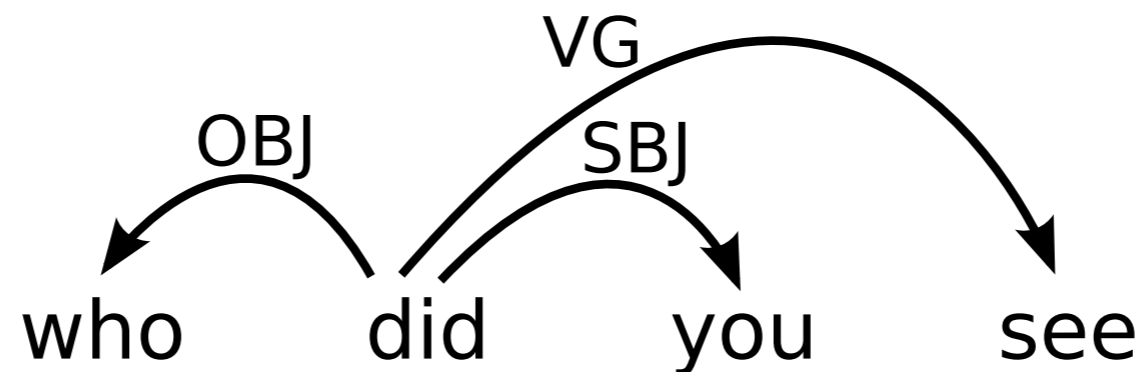

Transition-Based Parsing

Arc-eager shift-reduce parsing (Nivre, 2003)

Stack

[did, see]_S

Buffer

[]_B

Arcs

{ who $\xleftarrow{\text{OBJ}}$ did,
did $\xrightarrow{\text{SBJ}}$ you,
did $\xrightarrow{\text{VG}}$ see }

Right-arc
VG

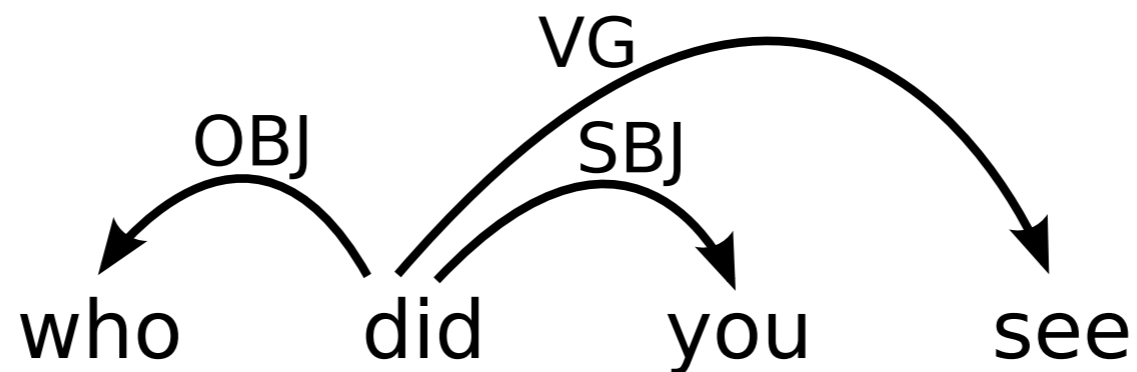

Transition-Based Parsing

Arc-eager shift-reduce parsing (Nivre, 2003)

Stack

[did, you]_S

Buffer

[see]_B

Arcs

{ who $\xleftarrow{\text{OBJ}}$ did,
did $\xrightarrow{\text{SBJ}}$ you }

Right-arc
SBJ

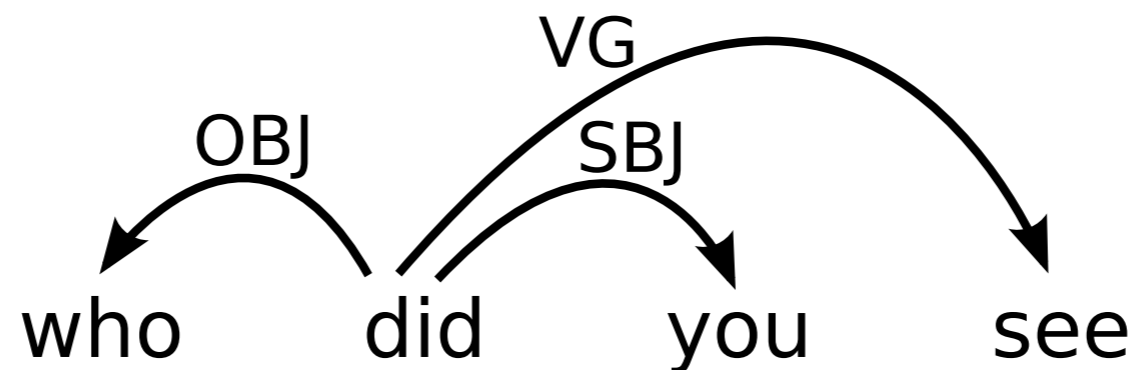

Transition-Based Parsing

Arc-eager shift-reduce parsing (Nivre, 2003)

Stack

[did, you]_S

Buffer

[see]_B

Arcs

{ who $\xleftarrow{\text{OBJ}}$ did,
did $\xrightarrow{\text{SBJ}}$ you }

Right-arc

SBJ

VG

Choose action w/best classifier score
100k - 1M features

Transition-Based Parsing

Arc-eager shift-reduce parsing (Nivre, 2003)

Stack

[did, you]_s

B

[s

Very fast linear-time performance
WSJ 23 (2k sentences) in 3 s

did → you }

Right-arc

SBJ

VG

Choose action w/best classifier score
100k - 1M features